



BA Group

12197, 12211, 12213 AND 12231 HURONTARIO STREET ARGO SUMMER VALLEY LIMITED

Traffic Impact and Parking Study
Plan of Subdivision Resubmission

Prepared For: Argo Summer Valley Limited

June 6, 2023



**MOVEMENT
IN URBAN
ENVIRONMENTS**

BAGROUP.COM

© BA Consulting Group Ltd.
45 St. Clair Avenue West, Suite 300
Toronto, ON M4V 1K9
www.bagroup.com

TABLE OF CONTENTS

EXECUTIVE SUMMARY	1
1.0 INTRODUCTION.....	5
1.1 Site Location And Context.....	5
1.2 Project Summary	6
1.3 Site Access and Circulation	6
1.4 Site Background	9
1.5 This Study	10
2.0 RESPONSE TO COMMENTS.....	11
2.1 Town of Caledon Comments – January 18, 2023	11
2.2 City of Brampton Comments – September 28, 2022	15
2.3 City of Brampton Comments – November 22, 2022	16
2.4 Region of Peel Comments – October 26, 2022.....	16
2.5 Ministry of Transportation Comments – August 30, 2022.....	17
3.0 PLANNING AND POLICY CONTEXT.....	18
3.1 Provincial Policies & Directives	18
3.2 Region of Peel Policies	18
3.3 City of Brampton Policies.....	19
4.0 STUDY AREA TRANSPORTATION INFRASTRUCTURE.....	21
4.1 Area Street Network	21
4.2 Area Transit Network	25
4.3 Area Cycling Network	28
4.4 Area Pedestrian Network	31
5.0 VEHICLE PARKING CONSIDERATIONS	34
5.1 Zoning By-law Requirements	34
5.2 Town of Caledon Development Standards Manual	35
5.3 Proposed Parking Supply.....	35
6.0 SIGHT LINE AND DESIGN REVIEW.....	37
6.1 Lighthouse Drive East-West Connection.....	37
7.0 TRAFFIC VOLUMES	39
7.1 Analysis Scenarios and Horizons	39
7.2 Existing Traffic Volumes	39
7.3 Background Traffic Volumes	42



7.4	Site Traffic Volumes.....	45
7.5	Future Total Traffic Volumes.....	46
8.0	VEHICLE TRAFFIC OPERATIONS ANALYSIS	50
8.1	Analysis Methodology	50
8.2	Network-Wide Parameters	50
8.3	Signalized Intersection Analysis Results	52
8.4	Unsignalized Intersection Analysis Results	53
8.5	Queue Analysis Results	54
8.6	Summary	55



LIST OF TABLES

Table 1	Development Proposal Summary	6
Table 2	Program Comparison (June 2022 to Current Proposal)	10
Table 3	Existing Area Street Network	21
Table 4	Existing Area Transit Network Service.....	25
Table 5	Summary of Existing Cycling Network.....	28
Table 6	Town of Caledon Zoning By-law 2006-50 Parking Requirements	34
Table 7	City of Brampton Zoning By-law 270-2004 Parking Requirements	35
Table 8	Proposed Parking Supply for Caledon & Brampton Lots.....	36
Table 9	TAC Minimum Sight Distance Requirements	38
Table 10	Existing Traffic Counts	39
Table 11	Background Developments.....	42
Table 12	Residential Trip Generation Rates.....	45
Table 13	Site Traffic Distribution	45
Table 14	Multi-Modal New site Trip Generation.....	46
Table 15	Hurontario Street & Collingwood Avenue / Highwood Road Capacity Analysis Results.....	52
Table 16	Highwood Road & Hillpath Crescent / McAlpine Road Analysis Results	53
Table 17	Future Total SimTraffic Queue Analysis Results	54

LIST OF FIGURES

Figure 1	Site Location	7
Figure 2	Site Context.....	8
Figure 3:	Area Road Network.....	23
Figure 4:	Existing Area Road Lane Configuration and Traffic Control.....	24
Figure 5:	Area Transit Context	27
Figure 6:	Area Bicycle Network.....	30
Figure 7:	Area Pedestrian Facilities	32
Figure 8:	Area Pedestrian Destinations	33
Figure 9:	Proposed Hurontario Street Reconfiguration.....	40
Figure 10:	Existing Traffic Volumes	41
Figure 11:	Future Background Traffic Volumes (2027).....	43
Figure 12:	Future Background Traffic Volumes (2032).....	44



Figure 13:	Site Traffic Volumes	47
Figure 14:	Future Total Traffic Volumes (2027)	48
Figure 15:	Future Total Traffic Volumes (2032)	49

TABLE OF APPENDICES

Appendix A	Reduced Scale Architectural Plans
Appendix B	Parking Allocation Plan
Appendix C	Functional Road Design and Vehicle Manoeuvring Diagrams
Appendix D	Pavement Marking and Signage Plan
Appendix E	Terms of Reference and Correspondence
Appendix F	Turning Movement Counts
Appendix G	Pages from ITE Trip Generation Manual
Appendix H	Transportation Tomorrow Survey (TTS) Data
Appendix I	Existing Signal Timing Plans
Appendix J	Synchro Worksheets
Appendix K	SimTraffic Worksheets



EXECUTIVE SUMMARY

The following provides a summary of the key findings of our transportation assessment of the Project.

Introduction

1. Argo Summer Valley Limited is filing applications for a Draft Plan of Subdivision to permit the redevelopment of the site. The proposed plan includes approximately 65 detached units.
2. The site is located in the northeast quadrant of the Hurontario Street and Collingwood Avenue/Highwood Road intersection. It is generally bounded by the Highway 410 and Highway 10 interchange to the north, existing detached residential uses to the east and south, and vacant lands to the west of Hurontario Street. The site is located within the City of Brampton's Snelgrove-Heart Lake Secondary Plan Area and Caledon's Mayfield West Secondary Plan Area.

Existing Conditions

3. The development site is comprised of two abutting properties, municipally known as 12197 Hurontario Street in the City of Brampton and 12231, 12211 & 12213 Hurontario Street in the Town of Caledon. The site (currently vacant) has no existing roads, sidewalks, transit or cycling facilities.
4. 12197 Hurontario Street, which is in the City of Brampton and located in the Snelgrove-Heart Lake Secondary Plan is designated as "Low Density Residential" according to the City's Official Plan Schedule A – General Land-Use Designations.
5. The lands 12231, 12211 & 12213 Hurontario Street, located in Caledon, are designated as Residential Policy Area B in the Town of Caledon's Official Plan.
6. The Town has also enacted an interim control by-law (2021-092) in the immediate area to control development adjacent to the future Mayfield West Transit Hub at the intersection of the Spine Road and Collector Road F within the Mayfield West Secondary Plan area. The site is located approximately 300 metres east of the proposed Transit Hub.

Former Uses and Previous Development Applications

7. The site, while currently vacant, was previously occupied by a trailer sales and auction centre, with direct access to Hurontario Street approximately 100 metres north of Highwood Road, and the southern portion of the site contained two residential dwellings, also with access to Hurontario Street.
8. A previously proposed development of the site included a proposed Neighbourhood Retail Centre between the City of Brampton and the Town of Caledon, which had contemplated a total of 9,290 sq. metres (100,000 sq. ft.) GFA. The applicant at that time proposed to re-designate the lands from "Low Density Residential" to "Neighbourhood Commercial" within the Snelgrove Secondary Plan and rezone the site from "Agricultural" to "Commercial Two".

9. The current proposal for these lands (consistent with the City's vision for the Snelgrove Secondary Plan) is a departure from the Retail Centre and will generate considerably less traffic than a neighbourhood retail centre at this location.

Planned Area Road Network Improvements

10. The following road improvements are already planned by the Province, Peel Region and the City of Brampton adjacent to or within the site Environs:
 - Spine Road – Mayfield West Phase 2 EA was initiated by the Town of Caledon to assess the construction of the new east-west Spine Road from Hurontario Street to Chinguacousy Road. The study area has been extended since to include the Highway 410 interchange with Hurontario Street / Valleywood Boulevard. The planned east-west Spine Road is intended to provide access to and connectivity between primary activity areas within the Mayfield West Phase 2 Stage 1 (MW2-S1) Lands and Mayfield West Phase 2 Stage 2 (MW2-S2) areas.
 - The GTA West Corridor (GTA West) is a proposed 4 to 6-lane, 59-kilometre 400-series highway and bus transitway proposed in the western Greater Toronto Area that will run east-west to the north of the Mayfield West area.

Planned Area Transit

11. Significant transit improvements are planned for the vicinity of the site to facilitate better access to the regional transit network. As identified in the TMP Rapid Transit Implementation by 2031 and 2041, Züm service along the Main Street / Hurontario Street will be further extended to make connections with two New Rapid Transit corridors (rail or bus service in exclusive lanes) along Main Street (Queen Street to Mayfield Road), and Queen Street (Main Street to Vaughan Metropolitan Centre).
12. A Future Transportation Corridor (within the GTA West or Boulevard), north of the site, also proposes an east-west transitway.
13. The Mayfield West Phase 2 plans include a transit hub on the proposed Spine Road approximately 200 metres (5-minute walk) west of the site, which will provide an interface between City of Brampton BRT routes, local buses and GO Transit routes travelling on Highway 410.
14. The combination of all the proposed changes to the network indicates that transit availability and accessibility will improve significantly in the future.

Planned Area Active Transportation

15. The Mayfield West Phase 2 EA identifies a new east-west Spine Road from Hurontario Street to Chinguacousy Road, planned to serve as a main pedestrian and cycling corridor, with the provision of on and off-street cycling and pedestrian routes.
16. The City's TMP has identified Hurontario Street and Mayfield Road as corridors for future facilities. Within the immediate vicinity of the site, Hurontario Street has been identified as a future right-of-way (on-road or in-boulevard) facility. Mayfield Road has been identified with a future off-road trail.

Vehicle Parking Considerations

17. Application of the Town of Caledon Zoning By-law 2006-50 (for the portion of the site located in the Town of Caledon) results in an overall requirement of 114 parking spaces.
18. Application of the City of Brampton Zoning By-law 270-2004 (to the portion of the site located within the City of Brampton) results in an overall requirement of 16 parking spaces, including 16 resident spaces and zero (0) visitor spaces.
19. The architectural stats for the proposed development indicate a total of 258 parking spaces. The proposed supply is to be allocated as follows:
 - Driveways and Parking Garages - 232 parking spaces
 - On-street - 26 parking spaces
20. 29 single detached dwellings with double driveway/garages will provide 4 spaces for each of the 29 units in the Town of Caledon portion of the development, which results in a total supply of 116 parking spaces. The remaining 28 units in Caledon lots with double driveways/single garages will provide 3 spaces for each of the 28 units, which results in 84 parking spaces. Thus, the overall supply of 200 parking spaces satisfies the parking required by the zoning by-law and the recommended rate by Development Standards Manual.
21. For the portion of the site located within the City of Brampton, the single detached dwellings with double driveway/garages will provide 4 spaces for each of the 8 units, which results in a total supply of 32 parking spaces for those units. For the detached dwellings with double garages/driveways, all of the parking required by the zoning by-law 270-2004 can be accommodated on each lot.
22. The proposed parking supply is considered appropriate and satisfies the Town of Caledon's Development Standards Manual requirement, Town of Caledon Zoning By-law 2006-50 and City of Brampton Zoning By-law 270-2004 requirements.

Traffic Volume Forecasting

23. The proposed development is expected to generate in the order of **50 two-way vehicle trips** during the morning peak hour and **65 two-way vehicle trips** during the afternoon peak hour.
24. The proposed development would generate in the order of **55 and 72 two-way person trips** during the weekday morning and afternoon peak hours, respectively.

Traffic Operation Analysis

25. Based on the analysis conducted by BA Group, the forecast vehicle site traffic generated by the proposed development will have minimal to minor impacts on the overall operation of the network signalized and unsignalized intersections.
26. All of the study area signalized and unsignalized intersections can acceptably accommodate site-related traffic activity and will continue to operate within the capacity and at acceptable levels of service under future conditions without the need for improvements.

27. All 50th and 95th percentile queue lengths are well-contained within their respective storage lengths during both peak hours under all conditions.

Overall

28. The proposed site plan arrangements, including vehicle access and parking provisions, are appropriate and will support the proposed development.

29. The site-generated trips can be acceptably accommodated by the area infrastructure during the weekday morning and afternoon peak hours.

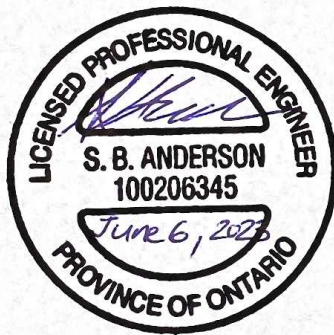

1.0 INTRODUCTION

BA Consulting Group Ltd (BA Group) has been retained by Argo Summer Valley Limited to provide transportation consulting services in relation to the proposed development of the Argo Summer Valley property (12197, 12211, 12213 and 12231 Hurontario Street) just south of Highway 410. The development site (the “**site**”) is generally within the northeast quadrant of the intersection of Hurontario Street and Collingwood Avenue / Highwood Road and includes lands within the City of Brampton (the “**City**”) and the Town of Caledon (the “**Town**”).

This report has been prepared in support of the Plan of Subdivision application being submitted to the City of Brampton and the Town of Caledon.

1.1 SITE LOCATION AND CONTEXT

1.1.1 Address and Policy Area

The development site is comprised of two abutting properties, municipally known as 12197 Hurontario Street in the City of Brampton and 12231, 12211 & 12213 Hurontario Street in the Town of Caledon. The site is located in the northeast quadrant of the Hurontario Street and Collingwood Avenue/ Highwood Road intersection. It is bounded by the Highway 410 and Highway 10 interchange to the north, existing detached residential uses to the east and south, and vacant lands to the west of Hurontario Street.

The site is located within the City of Brampton’s Snelgrove-Heart Lake Secondary Plan Area and Caledon’s Mayfield West Secondary Plan Area. The site location and context are illustrated in **Figure 1** and **Figure 2**.

1.1.2 Existing Land Use

The site has a frontage of approximately 203 metres on Hurontario Street and an area of approximately 3.6 hectares (8.978 acres). The lands are currently zoned as “Agricultural” under the City’s By-law 270-2004, as amended, and “High Commercial” and “Agricultural” under the Town’s Zoning By-law 2006-50.





12197 Hurontario Street, which is in the City of Brampton and located in the Snelgrove-Heart Lake Secondary Plan is designated as “Low Density Residential” according to the City’s Official Plan Schedule A – General Land-Use Designations. This Designation permits predominantly residential land-uses including a range of different dwelling types. The lands 12231, 12211 & 12213 Hurontario Street, located in Caledon, are designated as Residential Policy Area B in the Town of Caledon’s Official Plan. The Town has also enacted an interim control by-law (2021-092) in the immediate area (including the site) to control development adjacent to the future Mayfield West Transit Hub at the intersection of the Spine Road and Collector Road F within the Mayfield West Secondary Plan area. The site is approximately 200 metres east of the proposed Transit Hub and would be within the Major Transit Station Area.

1.2 PROJECT SUMMARY

A residential subdivision is proposed for the site, consisting of approximately 65 detached units. As part of the development, a new street ('McAlpine Road') is proposed off Highwood Road opposite Hillpath Crescent. McAlpine Road is proposed to form a loop within the subdivision and connect to Lighthouse Drive to the east. Lighthouse Drive is proposed to extend westward and connect to the new McAlpine Road. Vehicular access to the detached units is provided via driveways to the new McAlpine Road and Lighthouse Drive extension. The Project statistics are summarized in **Table 1**.

Reduced architectural plans are provided for reference in **Appendix A**.

TABLE 1 DEVELOPMENT PROPOSAL SUMMARY

Use		Development Proposal	
	Residential	Caledon	57 detached units
		Brampton	8 detached units
		Total	65 detached units
	Parking	Driveways and Parking Garages	232 spaces
		On-street	26 spaces
		Total	258 spaces
	Road	A new road (McAlpine Road) off Highwood Road opposite Hillpath Crescent and extending to Lighthouse Drive to the east	
	Access	Access to the detached units is provided via driveways to the new McAlpine Road and Lighthouse Drive extension	

Notes:

1. Based upon site statistics provided by Glen Schnarr & Associates Inc., dated June 5, 2023.

1.3 SITE ACCESS AND CIRCULATION

1.3.1 Vehicular site Access

Vehicular access to the proposed subdivision is provided via the new McAlpine Road and Lighthouse Drive extension that has an access point on Highwood Road. The proposed McAlpine road forms a four-legged intersection at the point of access with Highwood Road and aligns with the centreline of Hillpath Crescent. No access is proposed on Hurontario Street, and the existing access points on Hurontario Street that were used for the original lots will be removed.

The proposed public road provides access to the individual lots, as well as on-street parking spaces, and facilitates vehicular manoeuvres for garbage and fire trucks.



\\bafp02\data\WP\7597\06\Graphics\Adobe\ID's\7597-06.indd

Aerial maps provided courtesy of Esri, DigitalGlobe, GeoEye, Earthstar Geographics, CNES/Airbus DS, USDA, USGS, AeroGRID, IGN, the GIS User Community and/or Google Earth/Maps.

FIGURE 1 SITE LOCATION

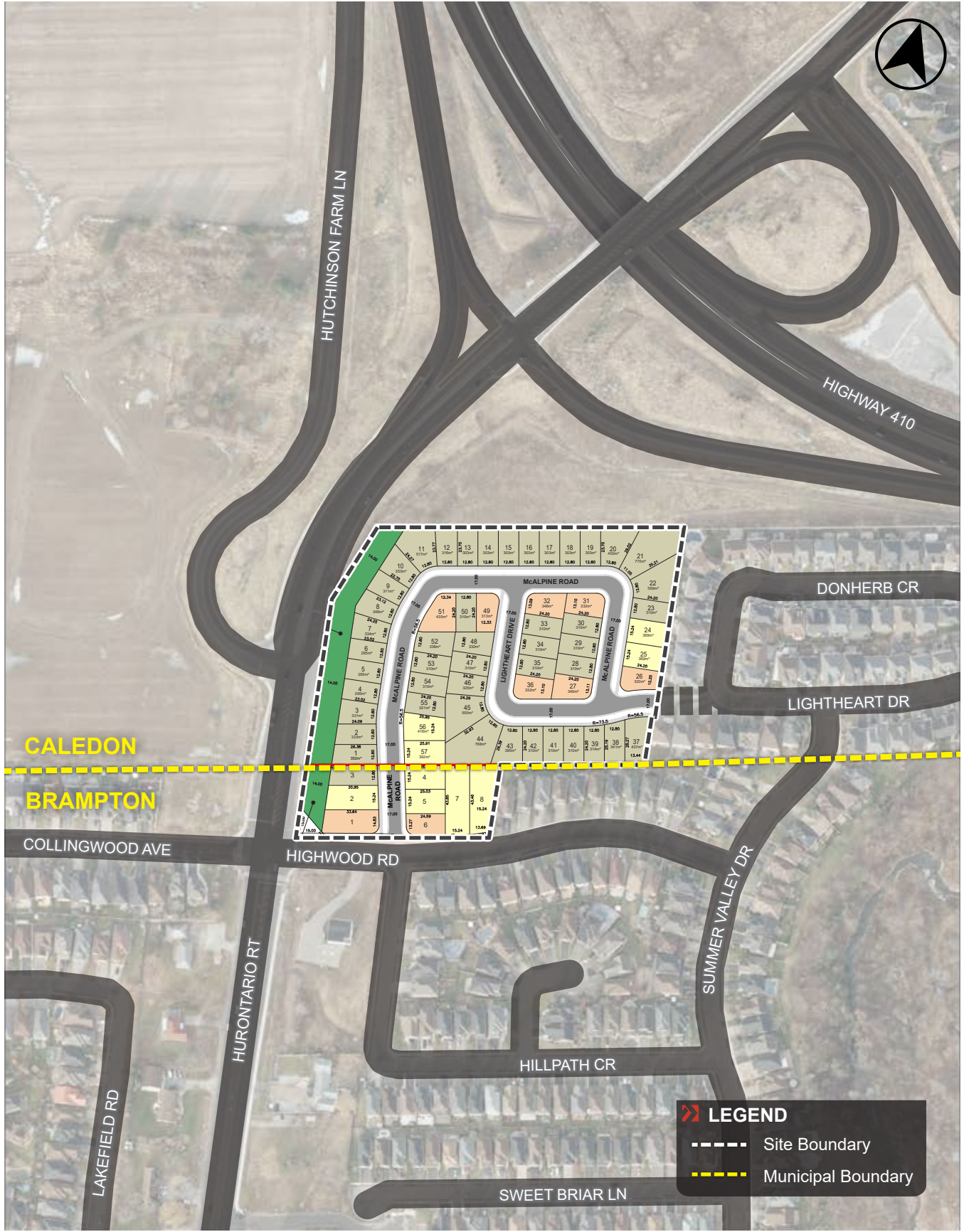

\\bafp02\data\WP\7597\06\Graphics\Adobe\ID's\7597-06.indd

Aerial maps provided courtesy of: Esri, DigitalGlobe, GeoEye, Earthstar Geographics, CNES/Airbus DS, USDA, USGS, AeroGRID, IGN, the GIS User Community and/or Google Earth/Maps.

FIGURE 2 SITE CONTEXT

1.3.2 Road Design Standards

The site is geographically located straddling the Brampton/Caledon border. The site connects to Highwood Road (a City of Brampton road) and Lighthead Drive (a Town of Caledon road) to the east and to all intents and purposes will be an extension of existing development patterns to the south and the east.

The internal site roads will be designed in accordance with the City of Brampton standards and will generally conform to the existing standard requirements for a Minor Local street in standard drawing 200, with a 17m ROW and an 8m pavement width. The adoption of the proposed road design standard on the Town of Caledon and the City of Brampton portions of the site will be in line with adjacent road design standards and is considered appropriate for the site.

1.4 SITE BACKGROUND

1.4.1 Former Development Applications

The site, while currently vacant, has contained development in the last decade. The northern portion of the site was previously occupied by a trailer sales and auction centre, with direct access to Hurontario Street approximately 100 metres north of Highwood Road, and the southern portion of the site contained two residential dwellings, also with access to Hurontario Street.

The site has had previous development proposals, including a proposed Neighbourhood Retail Centre between the City of Brampton and the Town of Caledon, which had contemplated a total of 9,290 sq. metres (100,000 sq. ft.) GFA. The applicant at that time proposed to re-designate the lands from “Low Density Residential” to “Neighbourhood Commercial” within the Snelgrove Secondary Plan and rezone the site from “Agricultural” to “Commercial Two”.

The current proposal for these lands (consistent with the City’s vision for the Snelgrove Secondary Plan) is a departure from the Retail Centre and will generate considerably less traffic than a neighbourhood retail centre at this location.

1.4.2 Previous Draft Plan of Subdivision Applications

The Draft Plan of Subdivision (DPOS) application was submitted to the City in June 2022. As part of the application, BA Group prepared a Traffic Impact and Parking Study titled “12197, 12211, 12213 and 12231 Hurontario Street, Argo Summer Valley Limited – Traffic Impact and Parking Study”, dated June 1, 2022 (“June 2022 Transportation Study”).

In response to comments received from the City of Brampton staff, BA Group prepared a memorandum titled “12197, 12211, 12213 and 12231 Hurontario Street (Argo Summer Valley Ltd.) – Plan of Subdivision – Traffic Impact and Parking Study Response to Comments”, dated August 5, 2022 (“August 2022 Transportation Memo”).

Comments on the above applications and supporting transportation studies were received from the City of Brampton, the Town of Caledon, the Region of Peel and the Ministry of Transportation. A resubmission of the DPOS application is now being made, one which reflects a site plan that has been revised to respond to this input and has also been further refined through the design development process.

A summary and comparison of the previous and current overall proposed development statistics are provided in **Table 2**.

TABLE 2 PROGRAM COMPARISON (JUNE 2022 TO CURRENT PROPOSAL)

	August 2022 Proposal	Current Proposal	Difference
Residential Units	36 detached units	65 detached units	+29 detached units
	45 townhouse units	0 townhouse units	-45 townhouse units
	81 total units	65 total units	-16 total units
Parking	274 spaces	258 spaces	- 16 spaces

1.5 THIS STUDY

This report provides an update regarding the transportation-related aspects of the development proposal and also responds to comments received from agency staff regarding the previous DPOS applications.

This report provides an assessment of the transportation-related aspects of the site, including:

- a summary of the existing land uses and proposed development program;
- a review of the area transportation context, including planned area transportation network improvements;
- an overview of key transportation-related design elements and their compatibility with the existing and planned community, completed studies, and ongoing studies; and
- a review of intersection operations in the study area under existing and future conditions including an assessment of the impacts of the Project.

The City of Brampton, the Town of Caledon, Peel Region, and the Province have a number of planned improvements for the area surrounding the site - notable improvements to transit connectivity, new active transportation links, and the adjacent road network identified in the:

- City and Regional Official Plans (OP, ROP)
- City and Regional Transportation Master Plans (TMP, LRTP);
- Mayfield West Phase 2 Transportation Assessment

Plans for road improvements approved and already underway by the City and Region will provide for significantly improved connectivity and mobility options for future site residents and visitors. Planned area road, transit, and active transportation improvements are outlined in **Section 4.0** of this report.

The transportation elements of the site have been thoughtfully designed to respect the vision of the TMP, existing and draft Secondary Plans, and existing approved EAs.

2.0 RESPONSE TO COMMENTS

2.1 TOWN OF CALEDON COMMENTS – JANUARY 18, 2023

Development Engineering (Road Network)

33. Staff acknowledges that other ROW within this area is 17 m and therefore have no concern with this right of way width so long as it can be demonstrated that all required infrastructure can be accommodated within this right of way width.

Response:

Acknowledged.

34. The Town will require a vehicular connection from Street 'A' in the proposed subdivision to Donherb Crescent through Block 80 on Plan 43M-1615. Ownership of the block is current by 1360287 Ontario Limited, however, there is a clause in the subdivision agreement for 43M-1615 that requires Block 80 to be conveyed to the Town free and clear of all encumbrance when required by the Town for a future road connection. The southern limit of the connection right of way should be aligned with the southern limit of the future road internal to the subdivision.

Response:

Acknowledged. The plans have been modified to provide a road connection to Lighthouse Drive.

35. All intersection angles shall be in the range of 85 degrees to 95 degrees and the minimum horizontal centerline curve radius is 65 m. Ensure all centerline radii meet this standard and are labelled on the draft plan

Response:

Acknowledged. Wherever possible, all intersection angles were adjusted using pavement markings to achieve an 85-to-95-degree intersection angle. The intersection of McAlpine Road and Lighthouse Drive could achieve a 89-degree angle with the centreline and 83 degrees to the pavement marking. Furthermore, Lighthouse Drive and McAlpine Road could achieve an 85-degree angle through adjustments to pavement markings.

All intersection angles fall within the range of 70 degrees and 90 degrees defined by TAC Manual section 9.4.5.4 and are considered appropriate. The pavement marking and signage plans are provided in **Appendix D**.

Transportation Engineering

60. Comments on the traffic analyses presented in the Traffic Impact and Parking Study (TIPS) will be deferred to the City of Brampton and MTO.

Response:

Acknowledged.

61. Please illustrate all the transit services noted in Table 3 in Figure 5 of the TIPS report, including the GO Transit stop.

Response:

Figure 5 has been updated to include all transit services and stops.

62. Please note that Caledon "Signed Bike Routes" are not identified in Figure 6 of the TIPS. Please revise accordingly.

Response:

Figure 6 has been updated to include the signed bike routes in the Town of Caledon.

63. Please demonstrate how the site will be connected to the surrounding bicycle facilities illustrated in the revised Figure 6.

Response:

The City of Brampton's Transportation Master Plan includes protected bike lanes or cycle tracks (separated) along Hurontario Street south of Highway 410, as illustrated in **Figure 6**. This planned cycling infrastructure allows the site to be connected to existing bicycle facilities in the City and the Town.

64. Please revise Figure 7 of the TIPS to illustrate the existing pedestrian facilities and transit stops and demonstrate how the site will be connected to them.

Response:

Area pedestrian facilities, including sidewalks, pedestrian crossings and traffic signals are illustrated in **Figure 7**. Transit stops in the area are illustrated in **Figure 7**. Area pedestrian destinations are illustrated in **Figure 8**.

As part of the development, sidewalks are proposed along the new McAlpine Road and Lighthouse Drive. The site is connected to the area pedestrian destinations and transit stops through these new sidewalks along with the existing sidewalks on Hurontario Street, Highwood Road, Collingwood Avenue, Hillpath Crescent and Summer Valley Drive.

65. On-Street parking spaces need to be longer than typical off-street spaces as they require enough space to accommodate vehicles entering and exiting. Although the Town currently doesn't have guidance for on-street parking dimensions, typical standards range from lengths of 6.7m to 7.0m. Please revise the on-street parking analysis presented in the Parking & Pedestrian Circulation Plan accordingly to ensure the on-street parking spaces are long enough to accommodate all required parking maneuvers.

Response:

While the Town of Caledon does not specify standard dimensions for on-street parking spaces, Section 6.17.1 of the City of Brampton Zoning By-law 270-2004 allows parallel parking spaces with 6.5m length for parking facilities. Therefore, a similar provision has been considered for on-street parking spaces situated between other parking spaces.

While a parallel parking space with a 6m (or lower) length cannot accommodate the entry and exit of a design vehicle if other cars are parked in adjacent spaces, a reduced length can be used for parking spaces at the

ends of parking areas where either entry or exit to the space is unobstructed. The proposed parking plan incorporates 5.4m long stalls for initial and final parking spaces, which can accommodate a 95 percentile design vehicle (equivalent to a Dodge Grand Caravan).

66. Please follow the Town's Traffic By-law to determine the adequate spacing between parking spaces and intersections/bends. Please also illustrate the locations of fire hydrants, which should be considered in the on-street parking analysis.

Response:

Acknowledged. Refer to the Parking Allocation Plan in **Appendix B**.

67. The Town will require a vehicular and pedestrian connection from Street 'A' in the proposed subdivision to Donherb Crescent through Block 80 on Plan 43M-1615. The southern limit of the connection right of way should be aligned with the southern limit of the future road internal to the subdivision.

Response:

Refer to the response to Comment #34.

68. Please provide an AutoTURN assessment illustrating the proposed design of Street 'A' can adequately accommodate all required vehicles. Please see attached snowplow truck dimensions (Layouts A, B and C) for the vehicles used by the Town and update the AutoTURN assessment accordingly. Layout B to the right has the bi-directional plow with wing dimensioned typical for most subdivision streets. Layouts A and C would be something to use for arterial and rural roads that may include village streets. Typically, the one-way plow extends further out in front but the wing dimensions that are not shown in Layout A and C would be the same as in Layout B. Layout C is the only one that shows the wing dimensions based on it set on the road.

Response:

Acknowledged. A similar vehicle template from the City of Barrie has been used, which resembles the Town of Caledon snowplow layout B. Updated vehicle manoeuvring diagrams are provided in **Appendix C**.

69. Please note that Transportation Engineering reserves the right for additional comments based on a revised submission. Transportation Engineering requests that the Traffic Consultant provide a response letter with the re-submission package clearly reiterating the Town's comments in order and including details for how each comment has been addressed.

Response:

Acknowledged.

70. The complete elimination of the requirements of a sight triangle is not appropriate. Please provide an appropriate alternative to ensure adequate sight lines are provided at local-to-local intersections within the Town's jurisdiction.

Response:

Corner rounding has been included at proposed intersections. Reduced-scale architectural site plans are provided in **Appendix A**.

Transportation Engineering (Draft Plan of Subdivision Comments)

71. Please illustrate the proposed pedestrian facilities within the site in the TIS, including but not limited to, sidewalks, crosswalks/PXO's, curb radii, widths of pedestrian facilities, signage and pavement markings, etc.

Response:

Acknowledged. Please refer to the functional road design in **Appendix C** and the pavement marking and signage plan in **Appendix D**.

72. A pedestrian crossing should be implemented at the location identified in the attached Summer Valley Circulation Plan from UD Brief_TE Markup. Please note that crossing specifications should comply with recommendations in OTM Book 15.

Response:

Within the subdivision, both pedestrian and vehicle volumes are expected to be low, and pedestrian or vehicle control measures (such as controlled crosswalks or all-way stop controls) are not warranted. All-way stop controls or marked crosswalks have not been implemented at similar locations in adjacent neighbourhoods in Caledon and Brampton (for example the existing intersections on Lighthouse Drive do not have all-way stops and marked crosswalks). Where especially low pedestrian and vehicle volumes occur, drivers may have a tendency to ignore unwarranted stop signs because the need to stop for another car or a pedestrian at the intersection is very infrequent. The presence of control measures may therefore lead to a false sense of security for pedestrians and could result in a worse condition compared to the case without marked crosswalks.

73. Town of Caledon Transportation Engineering request 2.0 m sidewalk widths in accordance with the 2017 Caledon Transportation Master Plan.

Response:

The City of Brampton's standards for a 17-metre ROW have been adopted, and include a sidewalk width of 1.5 metres.

74. Please note that Transportation Engineering reserves the right for additional comments based on a revised submission. Transportation Engineering requests that the Traffic Consultant provide a response letter with the re-submission package clearly reiterating the Town's comments in order and including details for how each comment has been addressed.

Response:

Acknowledged.

2.2 CITY OF BRAMPTON COMMENTS – SEPTEMBER 28, 2022

Transportation Development Engineering

2. The applicant will submit fully dimensioned functional design drawings for any permanent or temporary cul-de-sacs, roundabouts, intersections and road connections proposed within the subdivision, to ensure they meet all current city standards. Cul-de-Sacs are to adhere to City standard drawing #214. **Incomplete Sept 28, 2022**

Response:

The proposed development does not contain any permanent or temporary cul-de-sacs and a functional plan for proposed intersections and road connections is included in **Appendix C**.

5. A separate drawing is to be submitted depicting sidewalks, intersection daylighting dimensions, intersection curb radii, road elbows and driveway locations. Daylighting, curb radii, road elbows and driveway locations will be required to meet the current City standards or meet other satisfactory arrangements as determined by PW&E. Incomplete Sept 28, 2022

Response:

Acknowledged. Functional design plans are provided in **Appendix C**.

9. Driveways shall not encroach within intersection daylighting (rounded or triangles), and/or all driveway locations shall adhere to Section 10.12 of the residential zoning bylaw, which states “The minimum distance measured along a lot line between a driveway and the actual or projected point of intersection of two streets shall be 6.0 metres.” Where intersection daylighting exceeds 6.0 metres, driveways locations will not be permitted to encroach within intersection daylighting:

Response:

Proposed driveway locations are shown on the Parking Allocation Plan in **Appendix B**.

11. Road alignments - the horizontal and vertical alignments of all roads, including their intersection geometrics, shall be designed to the latest City standards and requirements.

Response:

Functional design plans are provided in **Appendix C** and reduced architectural plans are provided in **Appendix A**.

2.3 CITY OF BRAMPTON COMMENTS – NOVEMBER 22, 2022

Traffic Services Review

3. The TIS is to be revised to include the approved terms-of-reference and queuing analysis within a single report.

Response:

The Terms-of-Reference and correspondence with the City of Brampton staff are provided in **Appendix E**. The SimTraffic queue analysis results are discussed in **Section 8.5**. SimTraffic reports are attached in **Appendix K**.

4. The TIS and TIS memo reference a street named Collington Avenue. Where is this street?

Response:

“Collington Avenue” is a typographical error for Collingwood Avenue in the Synchro and SimTraffic reports provided in the appendices of the April 2022 Transportation Study and June 2022 Transportation memo. Updated Synchro and SimTraffic reports are provided in **Appendix J** and **Appendix K**, respectively.

5. Include a drawing depicting the Highwood Road lane configuration, including dimensions of lane widths, storage and taper lengths.

Response:

Acknowledged. Functional design plans are provided in **Appendix C**.

2.4 REGION OF PEEL COMMENTS – OCTOBER 26, 2022

Waste Management

3. The Turning Radius from the centre line must be a minimum of 13 metres on all turns. This includes the turning radii to the entrance and exit of the site.

Response:

Acknowledged. Functional design plans and vehicle manoeuvring diagrams illustrating a 13-metre centreline radii are provide in **Appendix C**.

2.5 MINISTRY OF TRANSPORTATION COMMENTS – AUGUST 30, 2022

Traffic Comments

1. Proponent to attach referenced pages of ITE trip gen manual in the TIS.

Response:

Acknowledged. Pages from the ITE Trip Generation Manual (11th Edition) related to Land Use 211 (Single-Family Detached Housing) are provided in **Appendix G**.

2. Proponent to update TIS with P.Eng stamp and signature.

Response:

Acknowledged.

3. Proponent to confirm SB queues on Hurontario St will not impact operations at MTO ramp terminals.

Response:

Queue analysis results are provided in **Section 8.5** of this report. All 50th and 95th percentile queue lengths are well-contained within their respective storage lengths during both peak hours under all conditions and will not pose significant impacts to adjacent intersections and MTO ramp terminals.

3.0 PLANNING AND POLICY CONTEXT

3.1 PROVINCIAL POLICIES & DIRECTIVES

The Places to Grow: Growth Plan for the Greater Golden Horseshoe (“Growth Plan”) outlines the importance of reducing reliance upon the automobile and promoting transit and active transportation. Planning along priority transit corridors, such as the GTA West corridor, shall be prioritized and planned for minimum density targets. The Growth Plan also highlights the importance of planning for the integration of active transportation within the existing and planned street network (e.g. complete streets) and development projects.

The GTA West Corridor (GTA West or Highway 413) is a proposed 4 to 6-lane, 59-kilometre 400-series highway and bus transitway in the western Greater Toronto Area. Implementation of this corridor is anticipated to significantly reduce travel times for drivers in York, Peel and Halton Regions. The proposed corridor would extend from Highway 400, between King Road and Kirby Road, to the 401/407 ETR interchange near Mississauga, Milton and Halton Hills. The proposed highway would have 11 interchanges at municipal roads, while the transitway would be a separate corridor running alongside the highway dedicated exclusively to public transit.

The Province’s EA is currently in Phase 2 (Alternative Designs) of the process, with the second Public Information Centre (PIC #2) undertaken in October 2019, in which the preferred route and interchange locations of the GTA West were announced. This route, with modifications, was confirmed publicly by the provincial government on August 7, 2020. Transportation-related elements of the EA are anticipated to be completed as part of the provincial EA.

3.2 REGION OF PEEL POLICIES

3.2.1 Region of Peel Official Plan (1996, latest consolidation: 2021)

The **Region of Peel Official Plan** (ROP) sets the planning policy framework to guide the future growth and development of the Region.

- The ROP provides general policies and direction for long-range strategic land use policy for the Region of Peel, including general shifts in goals and priorities relating to transportation;
- General support is indicated for facilitating a shift to promote public transit and other sustainable modes of transportation; as well as,
- Support for the integration of transportation planning, transportation investment and land use planning.

3.2.2 Let’s Move Peel Long Range Transportation Plan (2019)

The Long Range Transportation Plan (LRTP) is a five-year plan that guides transportation planning and infrastructure needs in the Region of Peel and sets out the blueprint to accommodate anticipated growth to 2041. The Plan serves as the basis for recommended Transportation Infrastructure Programming, the basis for the Transportation Capital Budget and 10-year Program, and is a key input into the Region’s Development Charges Background Study and By-law Update in 2020.

3.3 CITY OF BRAMPTON POLICIES

3.3.1 City of Brampton Official Plan (2006, latest consolidation: 2020)

The **City of Brampton Official Plan (OP)** sets the planning policy framework to guide the future growth and development of the City. It recognizes that the City's settlement area is nearly built out and most of the future development in the City will occur through intensification.

- The OP provides general policies and direction for future land use, including general shifts in goals and priorities relating to transportation.
- General support is indicated for facilitating a shift to sustainable transportation, supported by infrastructure and other initiatives; and
- Additional statements anticipate and indicate support for developments that propose reduced parking supplies.

3.3.2 City of Brampton Transportation Master Plan (2015)

The City of Brampton Transportation Master Plan (TMP) provides the framework for transit, cycling and other active transportation network expansions. The TMP is a key study that has been conducted by the City of Brampton to identify and plan for transportation network improvements to address existing issues and accommodate future growth in the area surrounding the proposed development site.

The TMP also proposes future connections, to be established in phases, including those that may currently be under review. site-specific recommendations include future cycling routes, support corridors for transit adjacent to the site, and active transportation connections. These multi-modal recommendations are considered under short, medium and long-term implementation timeframes.

As identified in the TMP Rapid Transit Implementation by 2031 and 2041, Züm service along the Main Street / Hurontario Street will be further extended to make connections with two New Rapid Transit corridors (rail or bus service in exclusive lanes) along Main Street (Queen Street to Mayfield Road), and Queen Street (Main Street to Vaughan Metropolitan Centre).

The City of Brampton initiated a review and update of the current TMP in December 2020, beginning with the identification of 3 objectives to inform the approach for the review. These include:

- the direction from the 2040 Vision for transportation planning and management which emphasizes travel choices and balancing infrastructure with alternative modes of travel;
- reconsideration of auto-centric network planning; and,
- public engagement to consider the impacts of transportation planning on the community, travel choices, and natural and built environments.

The official TMP Review process was planned to begin in early 2021 with an 18-month work plan.

3.3.3 City of Brampton Active Transportation Master Plan (2019)

The City of Brampton Active Transportation Master Plan (ATMP) is intended to define existing opportunities, consider and evaluate solutions, and identify a recommended active transportation system that provides comfortable and attractive pedestrian and bicycle facilities, in addition to supporting policies and programs.

The key focus of the ATMP includes:

- improving walking and cycling safety;
- providing options to all residents including improving accessibility of the transportation network;
- maximizing the value and usage of existing infrastructure;
- expanding the network;
- improving access to transit; and,
- utilizing active transportation as a viable first-mile / last-mile option.

4.0 STUDY AREA TRANSPORTATION INFRASTRUCTURE

4.1 AREA STREET NETWORK

4.1.1 Existing Area Road Network

A description of the road network within the site environs is provided in **Table 3** below and illustrated in **Figure 3**. The area road configuration and traffic control are illustrated in **Figure 4**.

TABLE 3 EXISTING AREA STREET NETWORK

	Name of Street	Description
MAJOR ARTERIAL	Hurontario Street	<p>A major arterial road under the jurisdiction of the City of Brampton that runs generally north-south along the western edge of the site. In the vicinity of the site, Hurontario Street operates with a 5-lane cross-section (including a centre left turn lane), plus an auxiliary northbound left turn lane at the signalized intersection of Hurontario Street / Collingwood Avenue south of the site.</p> <p>The posted speed limit is 70 km/h to the south of the site and 50 km/h just north of Hurontario Street and Highwood Road intersection.</p>
	Mayfield Road (Regional Road 14)	<p>A major arterial road under the jurisdiction of the Region of Peel that runs in an east-west direction south of the site. It extends from Highway 50 to the east and Winston Churchill Boulevard to the west. In the vicinity of the site, it currently has a 4-lane cross-section (two in each direction), with auxiliary left turns.</p> <p>West of the site, Mayfield Road has a two-lane rural cross-section and a speed limit of 70 km/h, and widens to four lanes with auxiliary left turns, at its intersection with Hurontario Street in the vicinity of the site with a posted speed limit of 60 km/h in both directions.</p>
LOCAL ROADS	Highwood Road / Collingwood Avenue	<p>A local road under the jurisdiction of Brampton that generally runs east-west along the southern edge of the site. The road extends from east of Hurontario Street to Summer Valley Drive (as Highwood Road), and west of Hurontario Street to Robertson Davies Drive (as Collingwood Avenue).</p> <p>The posted speed limit is 50 km/h.</p>
	Hillpath Crescent	<p>A two-way road serving a small section of townhomes along the south side of Highwood Road at its east end. It connects to Highwood Road via a stop control.</p>
	Summer Valley Drive	<p>A two-way road running north-south between Lighthead Drive and Mayfield Road. Summer Valley Drive has a 2-lane cross-section and a posted speed limit of 50 km/h.</p>

4.1.2 Planned Area Road Network

SPINE ROAD – MAYFIELD WEST PHASE 2

In 2016, a Class Environmental Assessment (EA) was initiated by the Town of Caledon to assess the construction of the new east-west Spine Road from Hurontario Street to Chinguacousy Road. The study area has been extended since to include the Highway 410 interchange with Hurontario Street / Valleywood Boulevard, given those modifications to the interchange would be necessary to maintain and accommodate the operation of the proposed Spine Road. The planned east-west Spine Road is intended to provide access to and connectivity between primary activity areas within the Mayfield West Phase 2 Stage 1 (MW2-S1) Lands and Mayfield West Phase 2 Stage 2 (MW2-S2) areas, with the capacity to support development. The Spine Road is being planned to accommodate transit service and to connect with the proposed transit hub planned in MW2-S1. It will serve as a main pedestrian and cycling corridor, with the provision of on and off-street cycling and pedestrian routes.

GTA WEST CORRIDOR PLANNING

The 'GTA West Transportation Corridor Route Planning and Environmental Assessment Study, Stage 2' Environmental Assessment (commenced in 2014 by the Province) is underway and is currently following both a Federal and Provincial Impact process to focus on identifying a route and preliminary design for a 400 series highway.

The GTA West (also known as Highway 413) is a proposed 4 to 6-lane, 59-kilometre 400-series highway and bus transitway in the western Greater Toronto Area. Implementation of this corridor is anticipated to reduce travel times for drivers in York, Peel and Halton Regions. The proposed corridor would extend from Highway 400, between King Road and Kirby Road, to the 401/407 ETR interchange near Mississauga, Milton and Halton Hills. The highway would have 11 interchanges at municipal roads, while the transitway would be a separate corridor running alongside the highway, dedicated exclusively for public transit.

The Province's EA is currently in Phase 2 (Alternative Designs) of the process, with the second Public Information Centre (PIC #2) having been undertaken in October 2019, in which the preferred route and interchange locations of the GTA West were announced. This route, with modifications, was confirmed publicly by the provincial government on August 7, 2020. Transportation-related elements of the EA are anticipated to be completed as part of the provincial EA.

The area existing and future road network context is illustrated in **Figure 3**.

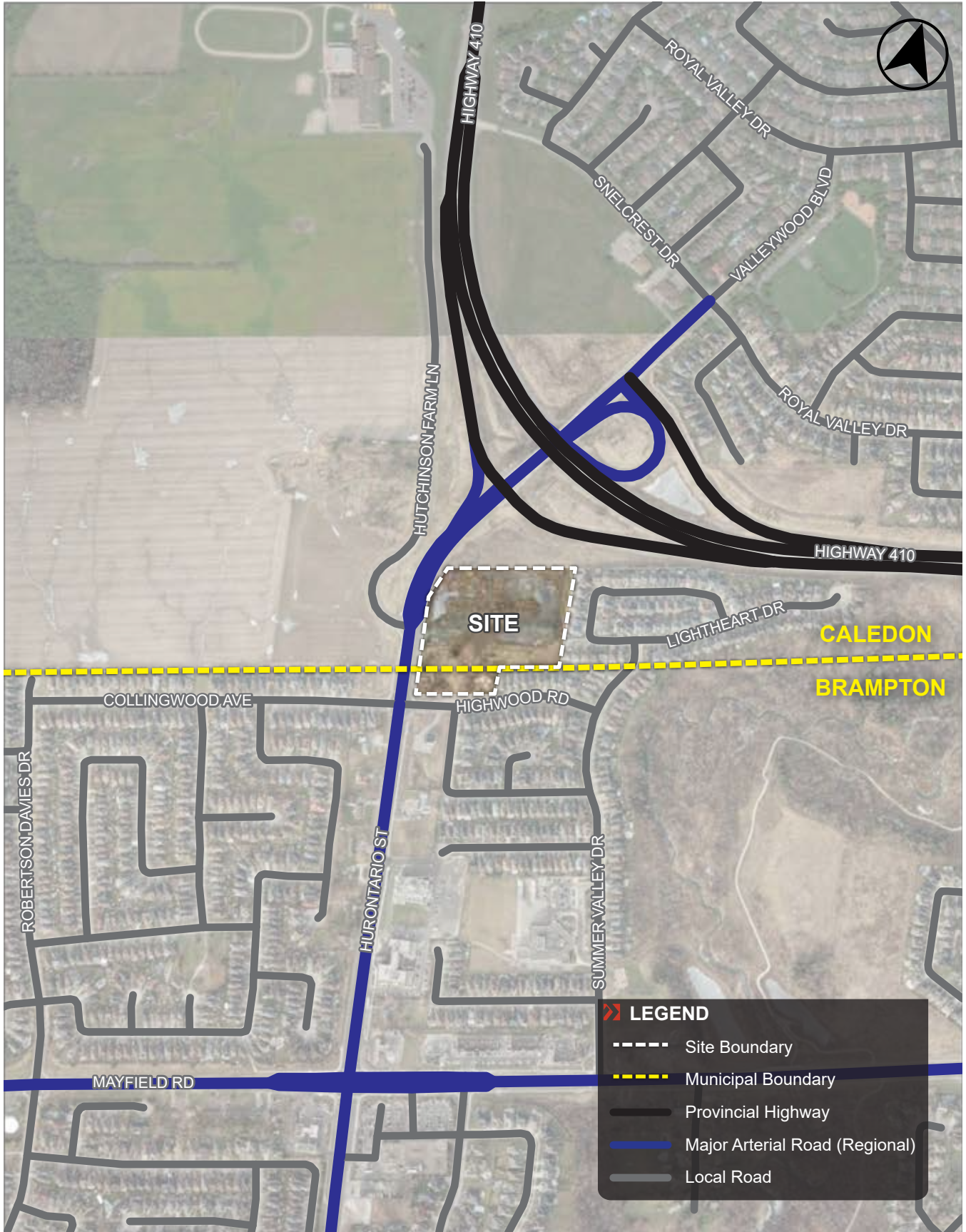

\\bafp02\data\WP\7597\06\Graphics\Adobe\ID's\7597-06.indd

Aerial maps provided courtesy of Esri, DigitalGlobe, GeoEye, Earthstar Geographics, CNES/Airbus DS, USDA, USGS, AeroGRID, IGN, the GIS User Community and/or Google Earth/Maps.

FIGURE 3 EXISTING STREET NETWORK

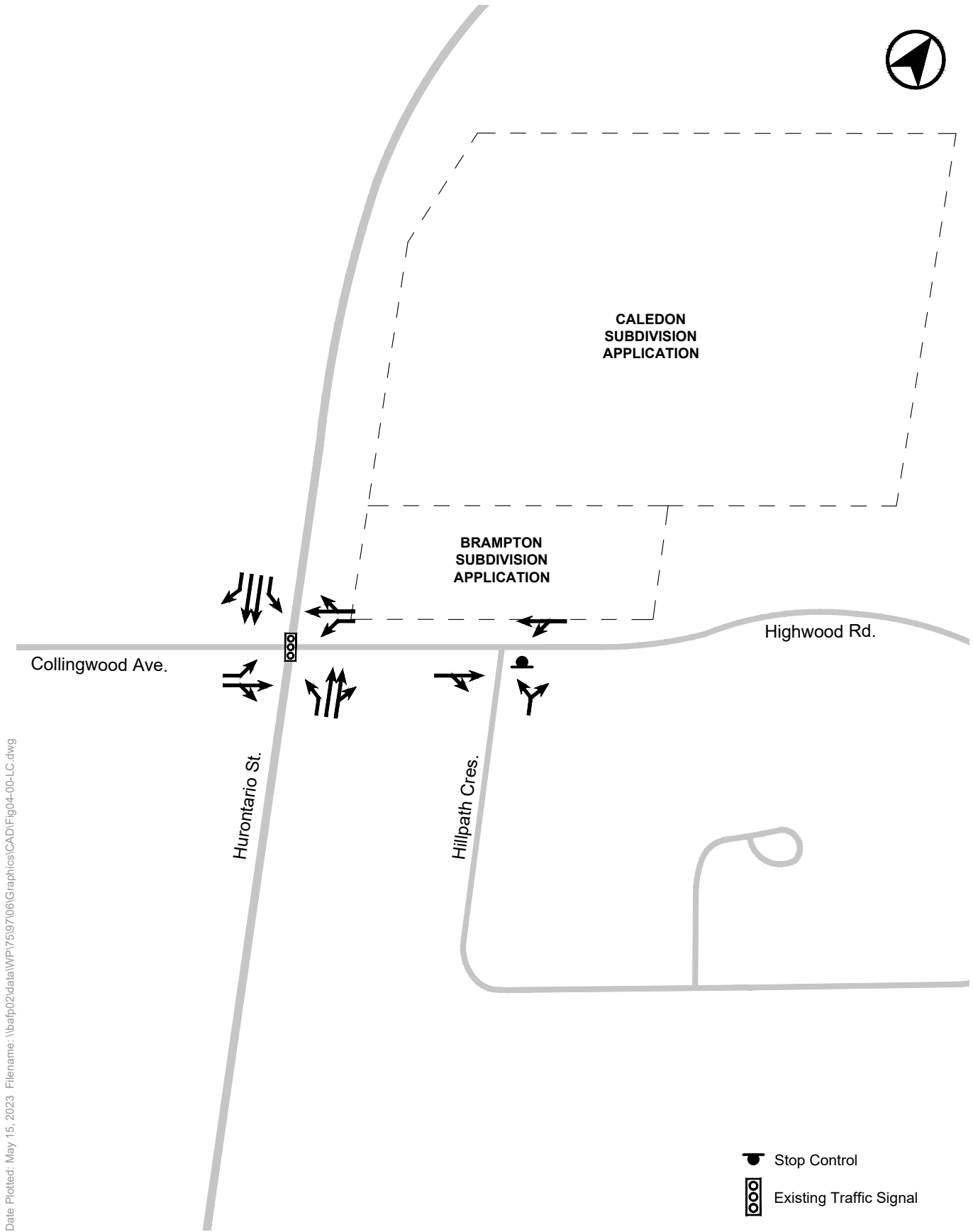

Date Plotted: May 15, 2023 Filename: \\bafp02\data\WPV75197106\Graphics\CAD\Fig04-00-LC.dwg

FIGURE 4 EXISTING AREA ROAD LANE CONFIGURATION AND TRAFFIC CONTROL

4.2 AREA TRANSIT NETWORK

4.2.1 Existing Transit Network

An overview of the key area transit routes in proximity to the site is summarized in **Table 4**. The area transit network is further illustrated in **Figure 5**.

TABLE 4 EXISTING AREA TRANSIT NETWORK SERVICE

	Route	Headway	Closest Stop	Description
Brampton Transit Local Bus Service (Züm)	24 – Van Kirk	20 minutes weekday peak ¹	Collingwood Avenue / Hurontario Street (Stop ID: 2204) ~150m from the site, 2-min walk	This bus route runs predominantly along Van Kirk Drive and surrounding neighbourhoods, eventually connecting back to the Downtown Brampton Terminal and Main Street Züm stations, where transit users are able to access buses 1, 1A 2, 24, 25, 52, 501, 501A, 502, and 561. Some of these routes connect to the Bramalea GO station.
	202 – Mayfield PM	Every weekday at 7:24 am	(Stop ID: 2662) ~900 m from the site, 11 min walk	Designated “school special” route: This bus route departs from Heart Lake Terminal, servicing various neighbourhoods along Hurontario Street and Mayfield Road, and ends at Mayfield Secondary School.
	204 – Mayfield PM	Every weekday at 3:13 pm	Mayfield Rd – end of Summer Valley Dr (Stop ID: 3355) ~650m from the site, 8 min walk	Designated “school special” route: This bus route departs from Mayfield Secondary School and ends at the Heart Lake Terminal.
	7/7A – Kennedy	15 – 21 minutes during weekdays	Mayfield Road, opposite Summer Valley Drive (Stop ID: 2662) ~900 m from the site, 11 min walk	This route runs primarily along Hurontario Street (north of Sandalwood Parkway), Mayfield Road, and Kennedy Road North, stopping at the Heart Lake terminal. The route runs from Mayfield Road down to Courtney Park Drive East and Derry Road, which would allow riders to access many Mississauga MiWay routes, including buses 15, 42, 53, 57, 19 and 103.
	81 – Mayfield West	~ 30 minutes during weekday peak periods	Hurontario Street s/ of Mayfield Road (Stop ID: 3355) ~800m from the site, 10-min walk	The bus routes run along Mayfield West between Hurontario Street and Kennedy Road North and the neighbourhood of Southfield Village. Route 81 connects back to the Sandalwood Loop, which provides access to buses 28 - Wanless and 502 – Züm Main.
GO Transit	37 – Brampton Terminal	~60-65 minutes during weekday peak, 75 minutes during off-peak	(Stop ID: 2205) ~550m from the site, 7 min walk	The 37 Brampton Term GO Bus travels along Hurontario Street between Orangeville Mall and Brampton GO. Route 37 only operates during weekdays.

Note:

Headways are reflected based on the assessment conducted in 2019. Due to the global COVID-19 (i.e. coronavirus) pandemic, Brampton Transit is currently (at the time of writing) operating with reduced service. It is expected and assumed that the reductions in service will revert to 'typical conditions' by the time this project is completed and therefore, the table is intended to represent 'typical conditions'.

4.2.2 Planned Area Transit

CITY RAPID TRANSIT IMPLEMENTATION TO 2031 AND 2041

The City of Brampton TMP includes a strategy to optimize the role of transit, including a recommended rapid transit implementation by the 2041 horizon year. Key improvements within the site's vicinity are outlined below:

- 2031 Recommended Rapid Transit Implementation
 - Identification of Mayfield Road as a “Support Corridor”
 - New Rapid Transit corridors (rail or bus service in exclusive lanes) are proposed along Main Street operating between Queen Street and Mayfield Road (west of the site); and Queen Street between Main Street and Vaughan Metropolitan Centre (south of the site).

- 2041 Recommended Rapid Transit Implementation
 - Expansion of the Züm network to include Sandalwood Parkway as a Zum corridor connecting to the Airport Road ZÜM and a Bramalea ZÜM
 - Continued identification of area Support Corridors (see note above).

The Mayfield West Phase 2 plans include a transit hub on the proposed Spine Road approximately 200 metres west of the site, that will provide an interface between City of Brampton BRT routes, local buses and GO Transit routes travelling on Highway 410. This proposed transit hub will be within a 5-minute walk of the site and will provide future residents of the site with easy access to a range of transit services.

HURONTARIO LRT

Hurontario Light Rail Transit (LRT) is an under-construction higher-order transit line that will add 18 kilometres of rapid connectivity along the Hurontario Street corridor, extending from Brampton Gateway Terminal at Steeles Avenue (12 km southeast of the proposed development) to Port Credit GO station (in Mississauga) in the south. The Hurontario LRT is scheduled to be completed in Fall 2024, will feature 19 stops, and provide direct connections to the Milton and Lakeshore West GO Transit Lines, Mississauga Transitway, Brampton Transit, Züm and MiWay.

A Hurontario LRT extension, connecting further north into Brampton, is currently in the planning stages. The City of Brampton is leading the “LRT Extension Study.” The project is focused on the Main Street South corridor, extending from Brampton Gateway Terminal in the south to Brampton GO Station (and the downtown Brampton area) in the north. The proposed route extension is currently undergoing an Environmental Assessment that is anticipated to be completed before the end of 2021, and construction is anticipated to begin within 6-10 years.



FIGURE 5 AREA TRANSIT NETWORK

\\bafp02\data\WP\7597\06\Graphics\Adobe\ID's\7597-06.indd

Aerial maps provided courtesy of: Esri, DigitalGlobe, GeoEye, Earthstar Geographics, CNES/Airbus DS, USDA, USGS, AeroGRID, IGN, the GIS User Community and/or Google Earth/Maps.





4.3 AREA CYCLING NETWORK

4.3.1 Existing Cycling Network

Under existing conditions, there are limited protected or dedicated cycling facilities in the site area. Area cycling facilities are limited to off-street multi-use trails and shared roadways marked as signed cycling routes. Dedicated (unprotected) urban shoulders are provided south of Mayfield Road along Colonel Bertram Road.

The existing cycling network is summarized in **Table 5**.

TABLE 5 SUMMARY OF EXISTING CYCLING NETWORK

Route	Type	Description	Image
Brampton			
Colonel Bertram Road	Urban Shoulder	Cyclists are in mixed traffic on this local road. This route is not signed. It extends along Colonel Bertram Road between Mayfield Road and Conservation Drive and is connected to the Etobicoke Creek Recreational Trail.	 Colonel Bertram Road – Facing south
Collingwood Avenue / Robertson Davies Drive	Urban Shoulder	Cyclists are in mixed traffic on these local roads. This route is not signed. It extends along Collingwood Avenue and Robertson Davies Drive between Hurontario Street and Mayfield Road.	 Collingwood Avenue – Facing west
Etobicoke Creek Recreational Trail	Multi-Use Trail	Cyclists are separated from traffic on this paved multi-use trail, which runs along Etobicoke Creek, extending between Old Kennedy Road in Caledon to the north and Downtown Brampton to the south. It is connected to a variety of on-road and off-road cycling routes in Brampton.	 Etobicoke Creek Trail – Facing south from Mayfield Road
Caledon			
Royal Valley Drive and Valleywood Boulevard	Shared on-Road Cycling Route	Cyclists are in mixed traffic on these local roads. This route is not signed. It extends along the circle of Royal Valley Drive and Valleywood Boulevard.	 Royal Valley Drive – Facing south

Route	Type	Description	Image
Lina Marino Park	Multi-Use Trail	Cyclists are separated from traffic on the paved multi-use trails within Lina Marino Park. The trails are connected to Valleywood Boulevard, Gardenia Way and Livingston Drive in the neighbourhood.	 <p data-bbox="1057 478 1419 527">Lina Marino Park – Facing east from Valleywood Boulevard</p>

4.3.2 Future Cycling Network

The Region of Peel and City of Brampton’s Transportation Master Plans (TMPs) include plans for cycling facilities in the vicinity of the site.

REGION OF PEEL

Future off-road trails are planned along Mayfield Road between Highway 50 and Winston Churchill Boulevard in the Region’s TMP.

CITY OF BRAMPTON

Future protected and separated bike lanes / cycle tracks are planned along Hurontario Road between Highway 410 and Highway 407. The section between Highway 410 and Bovaird Road is identified as a medium-term improvement. This planned facility is adjacent to the site and will provide direct connections between the site and other existing and planned cycling infrastructure in the area.

Within the site, cyclists will be with mixed traffic along the proposed new McAlpine Road and Lighthouse Drive.

The area bicycle network (existing and planned) is illustrated in **Figure 6**.

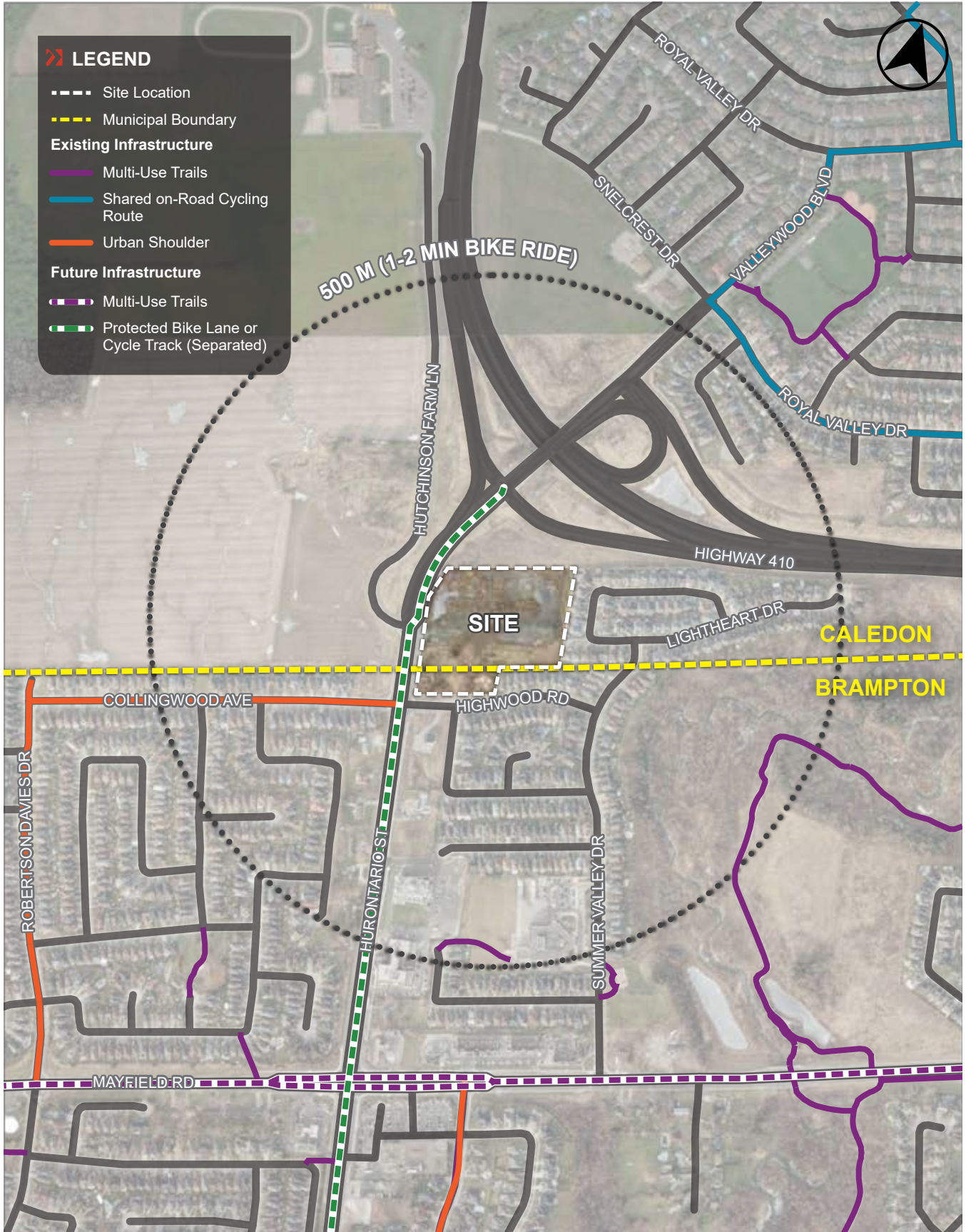

FIGURE 6 AREA CYCLING NETWORK

4.4 AREA PEDESTRIAN NETWORK

4.4.1 Existing Pedestrian Network

The site is located in a relatively suburban area that has only recently been planned for development. Formal paved sidewalks are provided on one side of the major arterial roads in the site vicinity with no paved boulevards typically separating the sidewalks and the roadways.

Within the site vicinity, formal and paved sidewalks are provided along the west side of Hurontario Street between Hutchinson Farm Lane and Highwood Road / Collingwood Avenue and the east side of Hurontario Street between Highwood Road / Collingwood Avenue and Mayfield Road. Within the neighbourhood, sidewalks are provided along both sides of Highwood Road, Collingwood Avenue, Hillpath Crescent and Summer Valley Drive and one side of Lighthouse Drive.

The site is located close to a provincial highway. Distances between signalized pedestrian crossings are long, which limits pedestrian permeability and routing opportunities. Pedestrian crossings at signalized intersections also tend to be significant in length, particularly for crossings of Hurontario Street and Mayfield Road.

4.4.2 Future Pedestrian Network

The proposed development provides opportunities to improve the public realm and pedestrian environment adjacent to the site. As part of the proposed development, sidewalks are provided along the new McAlpine Road and Lighthouse Drive. The proposed sidewalks will provide access to the proposed residential subdivision and improve neighbourhood connectivity for pedestrians.

The area pedestrian facilities are illustrated in **Figure 7**. Area pedestrian destinations are illustrated in **Figure 8**.

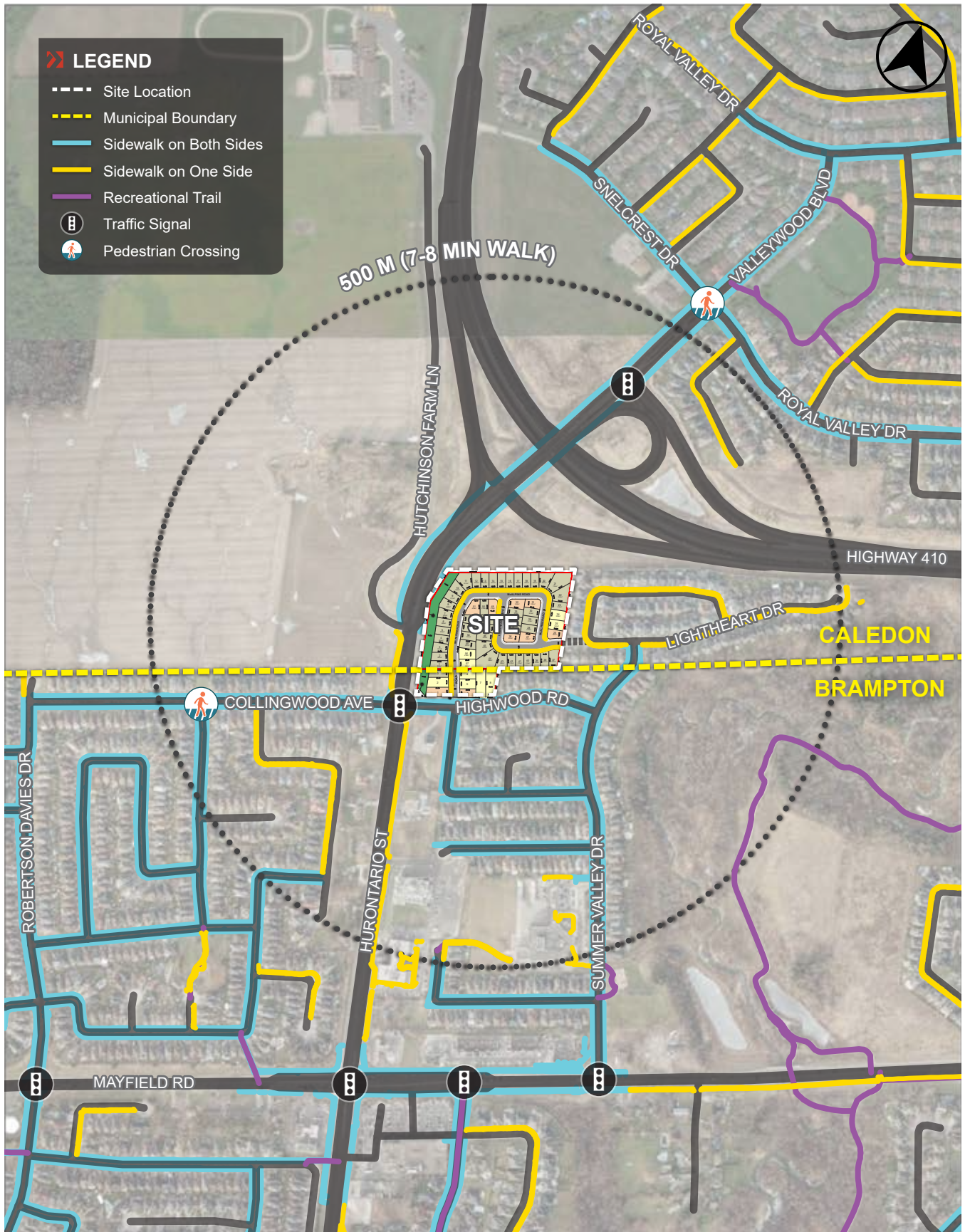

FIGURE 7 AREA PEDESTRIAN FACILITIES



\\bafp02\data\WP\7597\06\Graphics\Adobe\ID's\7597-06.indd

Aerial maps provided courtesy of Esri, DigitalGlobe, GeoEye, Earthstar Geographics, CNES/Airbus DS, USDA, USGS, AeroGRID, IGN, the GIS User Community and/or Google Earth/Maps.

FIGURE 8 AREA PEDESTRIAN DESTINATIONS

5.0 VEHICLE PARKING CONSIDERATIONS

5.1 ZONING BY-LAW REQUIREMENTS

5.1.1 Town of Caledon Zoning By-law 2006-50

The portion of the site located within the Town of Caledon is subject to the Town of Caledon Zoning By-law 2006-50.

Application of the minimum parking requirements of the Town of Caledon Zoning By-law 2006-50 for single detached units results in an overall requirement of 114 parking spaces, including 114 resident spaces and zero (0) visitor spaces. The minimum parking requirements based on the Town of Caledon Zoning By-law are summarized in **Table 6**.

TABLE 6 TOWN OF CALEDON ZONING BY-LAW 2006-50 PARKING REQUIREMENTS

Type	Use	Units	Minimum Parking Requirement	Number of Parking Spaces Required ¹
Resident	Single Detached	57 units	2 spaces / unit	114 spaces
	Subtotal	57 units	--	114 spaces
Visitor	Single Detached	57 units	0 spaces / unit	0 spaces
	Subtotal	57 units	--	0 spaces
Total		57 units	--	114 spaces

Notes:

1. Based upon site statistics provided by Glen Schnarr & Associates Inc., dated May 25, 2023.
2. The number of vehicle parking spaces is rounded up to the nearest whole number.

5.1.2 City of Brampton Zoning By-law 270-2004

For the portion of the site located within the City of Brampton (eight detached units), the site is subject to the City of Brampton Zoning By-law 270-2004.

Application of the minimum parking requirements of the City of Brampton Zoning By-law 270-2004 for single detached units results in an overall requirement of 16 parking spaces, including 16 resident spaces and zero (0) visitor spaces. The minimum parking requirements based on the City of Brampton Zoning By-law are summarized in **Table 7**.

TABLE 7 CITY OF BRAMPTON ZONING BY-LAW 270-2004 PARKING REQUIREMENTS

Type	Use	Units / GFA	Minimum Parking Requirement	Number of Parking Spaces Required ¹
Resident	Single Detached	8 units	2 spaces / unit	16 spaces
Visitor	Single Detached	8 units	0 spaces / unit	0 spaces
Total		8 units	--	16 spaces

Notes:

1. Based upon site statistics provided by Glen Schnarr & Associates Inc., dated June 5, 2023.
2. The number of vehicle parking spaces is rounded up to the nearest whole number.

5.2 TOWN OF CALEDON DEVELOPMENT STANDARDS MANUAL

For the portion of the development located in the Town of Caledon, the Town of Caledon Development Standards Manual requires 3.5 spaces / unit for the 57 units, including garages, driveways, and on-street parking, which results in a requirement of 200 parking spaces.

5.3 PROPOSED PARKING SUPPLY

29 single detached dwellings with double driveway/garages will provide 4 spaces for each of the 29 units in the Town of Caledon portion of the development, which results in a total supply of 116 parking spaces. The remaining 28 units in Caledon lots with double driveways/single garages will provide 3 spaces for each of the 28 units, which results in 84 parking spaces. Thus, the overall supply of 200 parking spaces satisfies the Caledon Development Standards Manual requirement of 3.5 spaces / unit, as well as the zoning by-law requirement of 2 spaces / unit. For the detached dwellings, all of the parking required by the zoning by-law and recommended in the Development Standards Manual can be accommodated on each lot.

In addition to the resident parking supply by driveways/garages, the on-street parking also provides a total of 24 parking spaces for the 57 units in the Caledon portion of the development proposal.

For the portion of the site located within the City of Brampton, the single detached dwellings with double driveway/garages will provide 4 spaces for each of the 8 units, which results in a total supply of 32 parking spaces for those units, which exceeds the Zoning By-law requirement of 2 spaces / unit. For the detached dwellings with double garages/driveways, all of the parking required by Zoning By-law 270-2004 can be accommodated on each lot. In addition to the total supply of 32 parking spaces, the on-street parking also provides 2 parking spaces for the 8 units in Brampton portion of the development proposal.

Table 8 summarizes the parking supply of the proposed development for the Caledon and Brampton lots.

TABLE 8 PROPOSED PARKING SUPPLY FOR CALEDON & BRAMPTON LOTS

Use	Units	Parking Supply Ratio	Number of Proposed Parking Spaces
<i>Residential – City of Brampton Zoning By-law</i>			
Single Detached (Double Driveway)	8 units	4 spaces / unit	32 spaces
Subtotal	8 units	--	32 spaces
<i>On-Street Parking Capacity – City of Brampton lots</i>			
Single Detached	8 units	0.25 spaces / unit	2 spaces
Subtotal	8 units	--	2 spaces
<i>Residential – Town of Caledon Zoning By-law</i>			
Single Detached (Double Garage/Double Driveway)	29 units	4 spaces / unit	116 spaces
Single Detached (Single Garage/Double Driveway)	28 units	3 spaces / unit	84 spaces
Subtotal	57 units	--	200 spaces
<i>On-Street Parking Capacity</i>			
Single Detached	57 units	0.42 spaces / unit	24 spaces
Subtotal	57 units	--	24 spaces
Total site	65 units	--	258 spaces

Notes:

1. Based upon site statistics provided by Glen Schnarr & Associates Inc., dated June 5, 2023.
2. The number of vehicle parking spaces is rounded up to the nearest whole number

6.0 SIGHT LINE AND DESIGN REVIEW

6.1 LIGHTHEART DRIVE EAST-WEST CONNECTION

Connecting the proposed subdivision to the existing Lighthouse Drive to the east as requested by the Town of Caledon resulted in potential alignment issues (i.e. a potential offset intersection) with the alignment of the internal subdivision loop road as it was laid out in the previous submission. As described below, with application of curves to address the offset, along with an assessment of stopping sight distance, the proposed road connection and the intersection of Lighthouse Drive and McAlpine Road is expected to function acceptably.

6.1.1 Geometric Design Adjustments and Compliance with Town's Centreline Radius

The potential offset between the existing Lighthouse Drive alignment to the east of the Site and the previously proposed internal road alignment has been addressed by adding two reverse horizontal curves. The proposed realignment is in compliance with the Town of Caledon minimum centreline radius of 65m, which is maintained at the right-of-way (ROW) centreline throughout the site. Since the City of Brampton's standard for a 17-metre ROW has been adopted, the cross section has a 1.5m offset centreline between the ROW and pavement centreline, which results in the 65m ROW radius becoming a 63.5m and 66.5m pavement centreline radii for the reverse curves. However, the radius for the east-west alignment effectively meets the Town's requirements. Given the anticipated low volume and low speed environment within the subdivision, reinforced by short block lengths and elbow bends, minor departures from minimum standards can be considered. Further details of centreline radii are illustrated on the functional road plan in **Appendix C**.

6.1.2 Stopping Sight Distance (SSD)

Provision of minimum stopping sight distance (SSD) allows drivers to bring their vehicles to a stop to avoid a collision. Section 2.5.3 of TAC Manual (2017)¹ defines minimum SSD of 50m and 65m for design speeds of 40km/h and 50km/h, respectively. Minimum SSD includes the distance travelled during the perception-reaction time and the braking distance to avoid conflict with objects on the road. For the following analysis, a vehicle turning out of the northern leg of the intersection on McAlpine Road is assumed as a potential conflict to vehicles travelling east-west on Lighthouse Drive.

Given the elbow curve to the west of the intersection, approaching vehicles from the west will be slowed down to an approximate operating speed of 20-30km/h due to the small centreline radius at the elbow (in this respect, road elbows can act as a traffic calming measure); vehicles coming from the west should have a low operating speed while exiting the elbow and heading eastbound towards the intersection. For a 40km/h design speed, a minimum 50m stopping sight distance is required, and there is almost 60m distance between the elbow and the intersection. Thus, SSD for a 40km/h design speed is available, which is appropriate for the western leg of the intersection, especially considering that lower operating speeds for eastbound vehicles will be likely.

For the eastern leg of the intersection, almost 70m distance is available between McAlpine Road and Donherb Crescent, which satisfies the minimum 65m SSD for a design speed of 50km/h. If vehicles make turns from Donherb Crescent or McAlpine Road and drive eastbound/westbound, sufficient intersection spacing and sightline is provided for a design speed of 50km/h to mitigate any potential conflicts.

¹ Chiu, M., Clayton, C., & Millen, G. (2017). Geometric Design Guide for Canadian Roads: Chapter 2-Design Controls, Classification and Consistency.

6.1.3 Decision Sight Distance (DSD)

Minimum stopping sight distance (as described above) provides an opportunity for the drivers to bring their vehicles to a stop to avoid a collision. Drivers may require longer sight distances at critical locations, such as intersections where several sources of information compete (TAC Manual, 2017)¹. Decision sight distance (DSD) has been defined as the distance at which drivers can detect a hazard or a signal in a cluttered roadway environment, recognize it or its potential threat, select an appropriate speed and path, and perform the required action safely and efficiently (McGee, 1979; Alexander & Lunenfeld, 1975).^{2,3}

Given that the proposed intersection is a T intersection in a local residential neighbourhood with low traffic volume and anticipated low operating speeds, we consider that the proposed intersection of McAlpine Road and Lighthouse Drive is not a complex environment, and that provision of minimum DSD is not necessary.

6.1.4 Intersection Sight Distance (ISD)

Sight distance has been evaluated based on TAC design criteria for the northern leg of the intersection (McAlpine Road). As summarized in **Table 9**, for a vehicle driving eastbound with an approximate operating speed of 20-30km/h as mentioned in **Section 6.1.2**, intersection sight distances of 45m and 65m are available for a design speed of 20km/h and 30km/h, respectively. Since vehicles exiting the elbow and heading eastbound towards the intersection should have a low operating speed, a low design speed assumption is appropriate in this scenario. The current functional road plan contains an approximate 50m ISD, which falls within the range of required ISD for a 20km/h to 30km/h design speed.

For the eastern leg of the intersection and vehicles driving westbound, unlimited and unobstructed ISD is available, with no sight line obstructions to impede drivers' vision.

TABLE 9 TAC MINIMUM SIGHT DISTANCE REQUIREMENTS

Minor Road	Major Road	Design Speed Assumption	Intersection Control	TAC Minimum Sight Distance Required (ISD)	Requirements Satisfied
McAlpine Road	Lighthouse Drive – Western Leg	20-30 km/h Exiting the elbow	Case B1 – Left turn from the minor road	45 – 65 m	For a design speed of 20-30 km/h
McAlpine Road	Lighthouse Drive – Eastern Leg	> 50 km/h	Case B1 – Left turn from the minor road	Unlimited	Yes

¹ Chiu, M., Clayton, C., & Millen, G. (2017). Geometric Design Guide for Canadian Roads: Chapter 2-Design Controls, Classification and Consistency.

² McGee, H. W. (1979). Decision sight distance for highway design and traffic control requirements. Transportation research record, 736, 11-13.

³ Alexander, G. J., & Lunenfeld, H. (1975). Positive guidance in traffic control. US Department of Transportation, Federal Highway Administration, Office of Traffic Operations.

7.0 TRAFFIC VOLUMES

7.1 ANALYSIS SCENARIOS AND HORIZONS

Traffic analyses have been completed for the following weekday morning and afternoon peak hour scenarios:

- **Existing Traffic** – volumes on the road network under existing conditions.
- **Future Background Traffic** – volumes in the future prior to the build-out of the site which consider other area developments.
- **Future Total Traffic** – volumes in the future after the build-out of the site, inclusive of other area developments.

The following two planning horizons have been considered in this study for the analysis of future conditions:

- **Future 2027 (5-year horizon)** – presumes reduced allowable developments prior to the completion of the Mayfield West Phase 2 TMP.
- **Future 2032 (10-year horizon)** – presumes full build-out of the Mayfield West Phase 2 TMP area. The future traffic volumes after the completion of the Mayfield West Phase 2 are illustrated in **Figures 2.6 and 2.7** (2031 Total Traffic Volumes) of the January 2018 *Mayfield West Phase 2 Stage 2 Transportation Assessment*.

7.2 EXISTING TRAFFIC VOLUMES

Base existing traffic volumes were established for the weekday morning and afternoon peak hours (the busiest hour of traffic between 7:30-9:30 am and 4:00-6:00 pm respectively) for intersections within the study area, based on traffic count information collected by Spectrum Traffic Inc. on behalf of BA Group.

The traffic count information adopted as the basis for the traffic operations analysis undertaken to assess the operational impacts of the proposed development is summarized in **Table 10**.

TABLE 10 EXISTING TRAFFIC COUNTS

Intersections	Date of Counts	Source
Hurontario Street / Collingwood Avenue-Highwood Road	Thu, Jan 20, 2022	Spectrum Traffic Data Inc.
Hillpath Crescent / Highwood Road		

The existing turning movement counts were reviewed in detail to ensure general consistency in the traffic volumes on roadways between intersections. Where necessary, minor adjustments were made to balance traffic volumes between intersections to create a representative traffic volume base for the purposes of the traffic operations analyses undertaken as part of this study.

Weekday morning and afternoon peak hour traffic volumes in the study area adopted for this analysis are illustrated in **Figure 10**. Turning movement counts are attached in **Appendix F**.



FIGURE 9 PROPOSED HURONTARIO STREET RECONFIGURATION

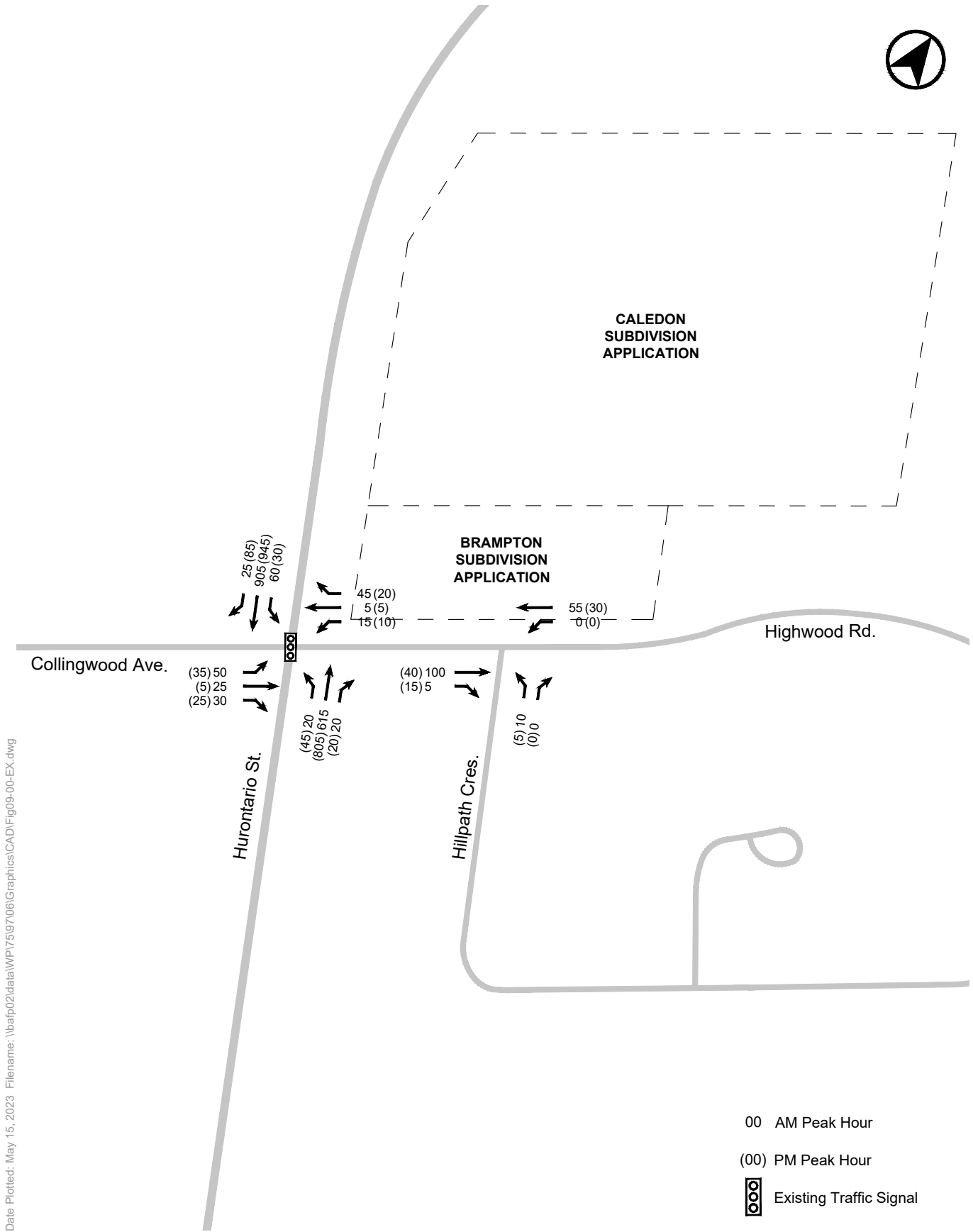

Date Plotted: May 15, 2023 Filename: \\bafp02\data\WPV75197106\Graphics\CAD\Fig09-00-EX.dwg

FIGURE 10 EXISTING TRAFFIC VOLUMES

7.3 BACKGROUND TRAFFIC VOLUMES

7.3.1 Corridor Growth

An average growth rate of 2.0% per annum was applied along the corridors of Hurontario Street, consistent with the corridor growth assumptions adopted in the *Mayfield West Phase 2 Stage 2 Transportation Assessment* report.

7.3.2 Background Developments (2027 Horizon)

Allowances were made to account for new traffic generated by other development proposals in the area that are either under construction, approved, being reviewed or for which an application is expected to be submitted to the City in the near future. A total of 2 development proposals have been considered for the 2027 horizon, which represents approximately 401 residential units. Background developments included in this analysis are summarized in **Table 11**.

Trip generation rates and traffic assignments adopted for each background development are based upon the information contained in the traffic impact studies (TIS) prepared for each project. Where no traffic volumes and distributions were available for a specific background development, trip generation rates and traffic distribution assumptions have been adopted consistent with this development application.

TABLE 11 BACKGROUND DEVELOPMENTS

Developments	Development Statistics	Sources	Date	Status
2247, 2257, 2271 Mayfield Road	200 residential units	nexTrans	Nov 2020	Under Review
12089 Hurontario Street	201 residential units	C.F. Crozier & Associates	Mar 2021	Under Review
Total	401 residential units			

7.3.3 Future Background Traffic (2027 Horizon)

Future background traffic volumes for the 2027 horizon, representing the sum of existing traffic volumes, corridor growth volumes and background development traffic volumes, are illustrated in **Figure 11**.

7.3.4 Future Background Traffic (2032 Horizon)

Future background traffic volumes for the 2032 horizon were developed based on 2031 Total Traffic (**Figures 2.6 and 2.7**) volumes from the January 2018 *Mayfield West Phase 2 Stage 2 Transportation Assessment* report by Paradigm Transportation Solutions Ltd. The traffic volumes along Hurontario Street were assumed to be consistent with projected 2031 volumes south of Hurontario Street / Spine Road-Valleywood Boulevard. The turning volumes and minor street volumes were assumed to be consistent with the 2027 horizon. Future background traffic volumes for the 2032 horizon are illustrated in **Figure 12**.

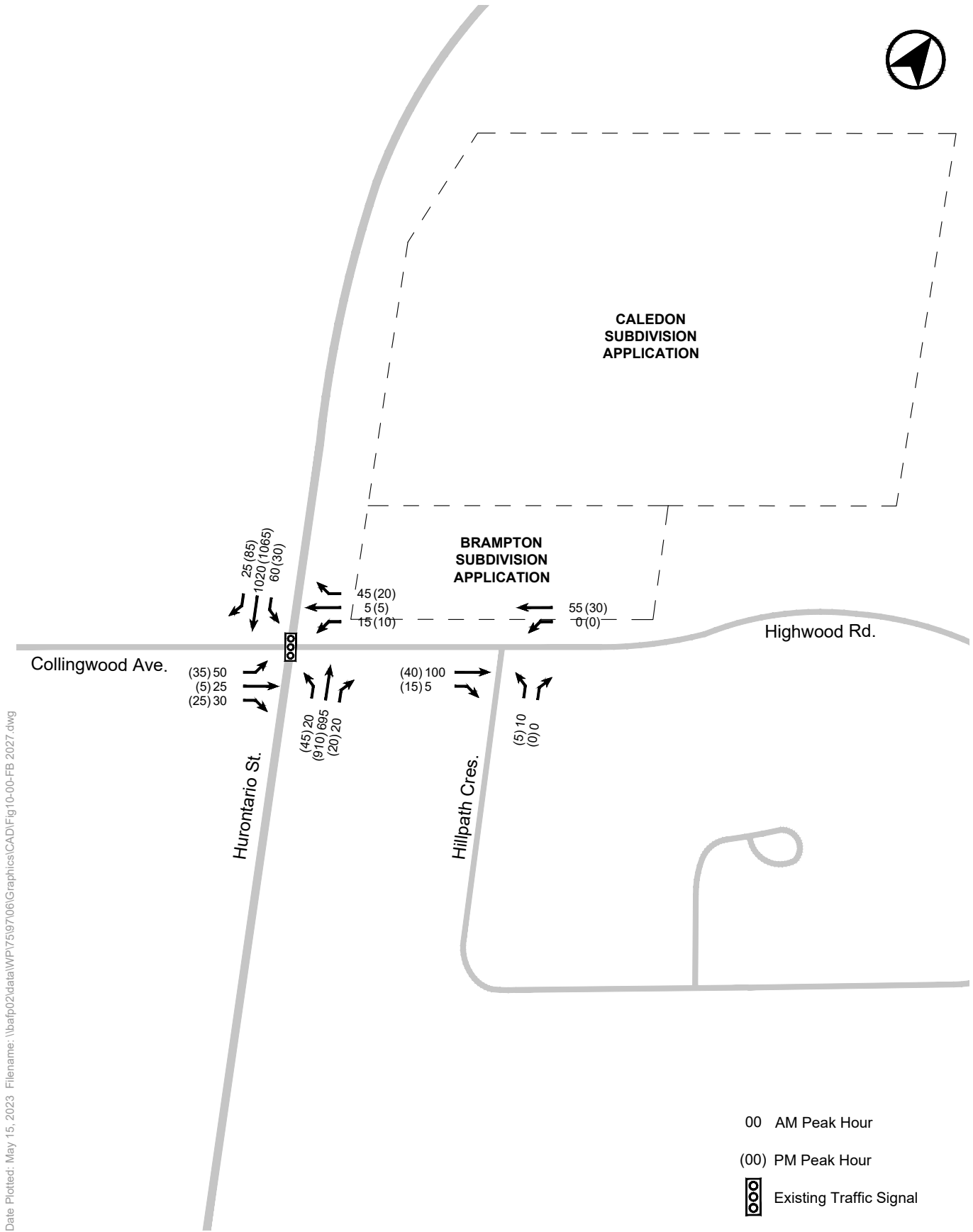

Date Plotted: May 15, 2023 Filename: \\bafp02\data\WP\75197106\Graphics\CAD\Fig10-00-FB 2027.dwg

FIGURE 11 FUTURE BACKGROUND TRAFFIC VOLUMES (2027)

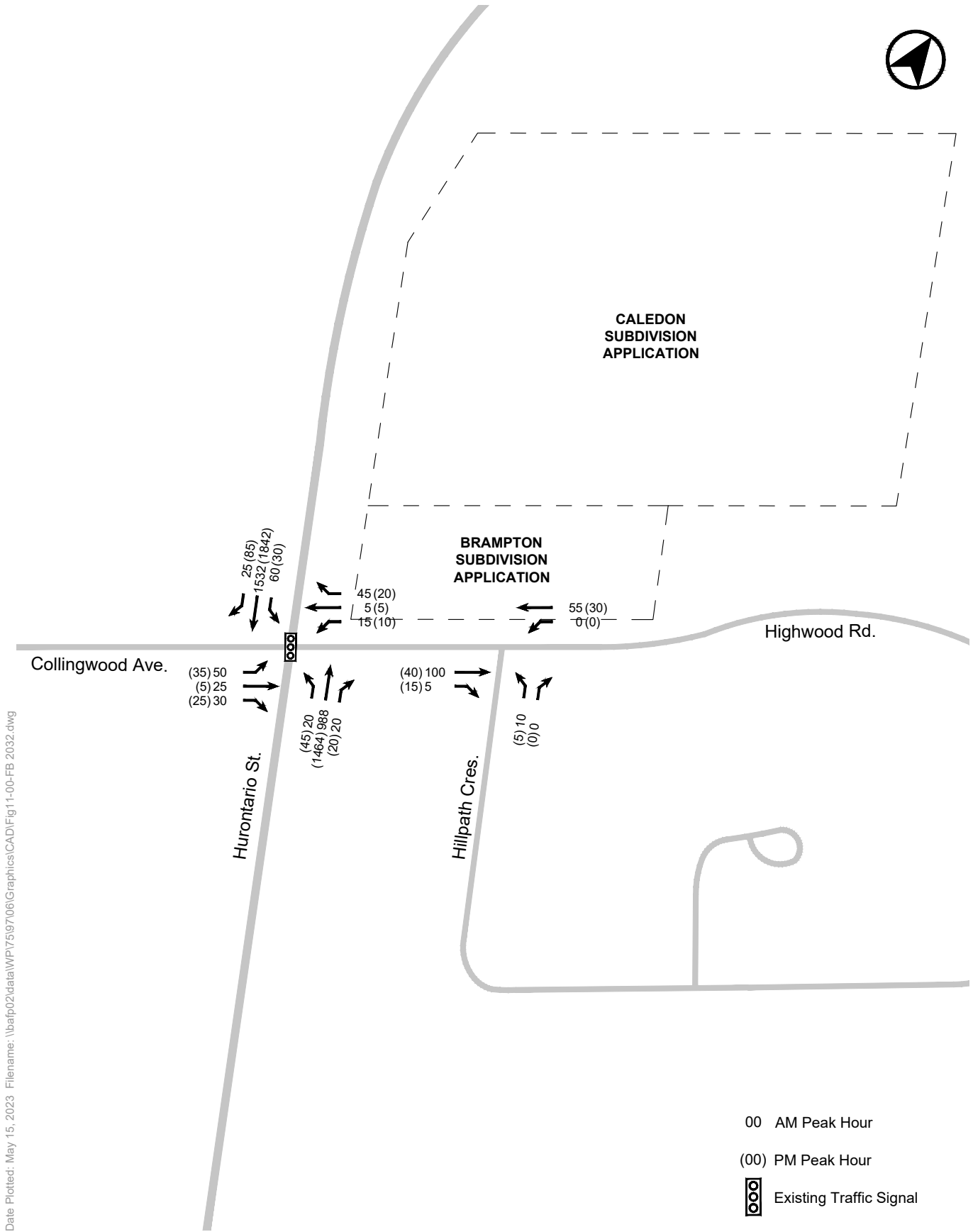

Date Plotted: May 15, 2023 Filename: \\bafp02\data\WPV75197106\Graphics\CAD\Fig11+00-FB 2032.dwg

FIGURE 12 FUTURE BACKGROUND TRAFFIC VOLUMES (2032)

7.4 SITE TRAFFIC VOLUMES

7.4.1 Residential site Traffic Generation

Details of the proposed trip generation rates for the site in weekday morning and afternoon peak hours are summarized in **Table 12**. The Institute of Transportation Engineers (ITE) Trip Generation Manual, 11th Edition was applied for low-rise residential units on the site.

TABLE 12 RESIDENTIAL TRIP GENERATION RATES

Land Use	Size	AM Peak Hour			PM Peak Hour		
		In	Out	2-Way	In	Out	2-Way
Single-Family Detached Housing (LU 210)	65 units	15	35	50	40	25	65

Notes:

1. Vehicle trips have been rounded to the nearest 5.

The proposed development is expected to generate in the order of **50 two-way vehicle trips** during the morning peak hour and **65 two-way vehicle trips** during the afternoon peak hour.

7.4.2 Site Traffic Distribution and Assignment

Site traffic has been assigned onto the area road network based on a review of travel information provided by the 2016 Transportation for Tomorrow Survey (TTS) and existing road network traffic patterns and connectivity. The site traffic distribution is summarized in **Table 13**. Detailed output TTS data and distribution assumptions are included in **Appendix H**.

TABLE 13 SITE TRAFFIC DISTRIBUTION

Directions	Outbound ¹	Inbound ²
To / From the North on Hurontario Street	10%	5%
To / From the South on Hurontario Street ³	50%	45%
To / From the East on Highway 410	35%	45%
To / From the East on Mayfield Road	5%	5%
To / From the West on Mayfield Road	0%	0%
Total	100%	100%

Notes:

1. Based upon morning peak period residential outbound trips.
2. Based upon afternoon peak period residential inbound trips.
3. Based on trips to/from households in TTS zones 3007, 3381 and 3459.

New site traffic generated by the proposed development was assigned onto the area road network based on the directional distribution summarized in **Table 13**. New site traffic volumes for the weekday morning and afternoon peak hours are illustrated in **Figure 13**.

Based on the projected site traffic assignment, it is estimated that approximately 5% of the new site trips will utilize Lighthouse Drive to access Mayfield Road. This is equivalent to an additional 3 vehicles on Lighthouse

Drive and Summer Valley Drive during peak hours. As a result, the proposed development is not expected to have a significant impact on the neighbourhood traffic.

7.4.3 Multi-Modal Trip Generation

In addition to the vehicular trip generation for the proposed development, BA Group has developed forecasts of activity levels for other travel modes using modal split information for the area provided by the 2016 TTS data and site-related traffic forecasts, as summarized in **Table 14**.

TABLE 14 MULTI-MODAL NEW SITE TRIP GENERATION

	AM Peak Hour			PM Peak Hour		
	In	Out	2-Way	In	Out	2-Way
Area Mode Split						
Driver	68%	66%		68%	66%	
Passenger	20%	27%		20%	27%	
Transit	11%	7%		11%	7%	
Walk	1%	0%		1%	0%	
Cycle	0%	0%		0%	0%	
Total	100%	100%		100%	100%	
Multi-Modal Trip Generation						
Driver	12	25	37	31	18	49
Passenger	3	10	13	9	7	16
Transit	2	3	5	5	2	7
Walk	0	0	0	0	0	0
Cycle	0	0	0	0	0	0
Total	17	38	55	45	27	72

Notes:

1. Inbound mode-splits based on afternoon peak period residential inbound trips,
2. Outbound mode splits based on morning peak period residential outbound trips.
3. Based on trips to/from households in TTS zones 3007, 3381 and 3459.

Based on the foregoing, the proposed development would generate in the order of **55 and 72 two-way person trips** during the weekday morning and afternoon peak hours, respectively.

7.5 FUTURE TOTAL TRAFFIC VOLUMES

Future total traffic volumes, reflecting the addition of new site traffic volumes and future background traffic volumes are illustrated in **Figure 14** for the 2027 horizon and **Figure 15** for the 2032 horizon.

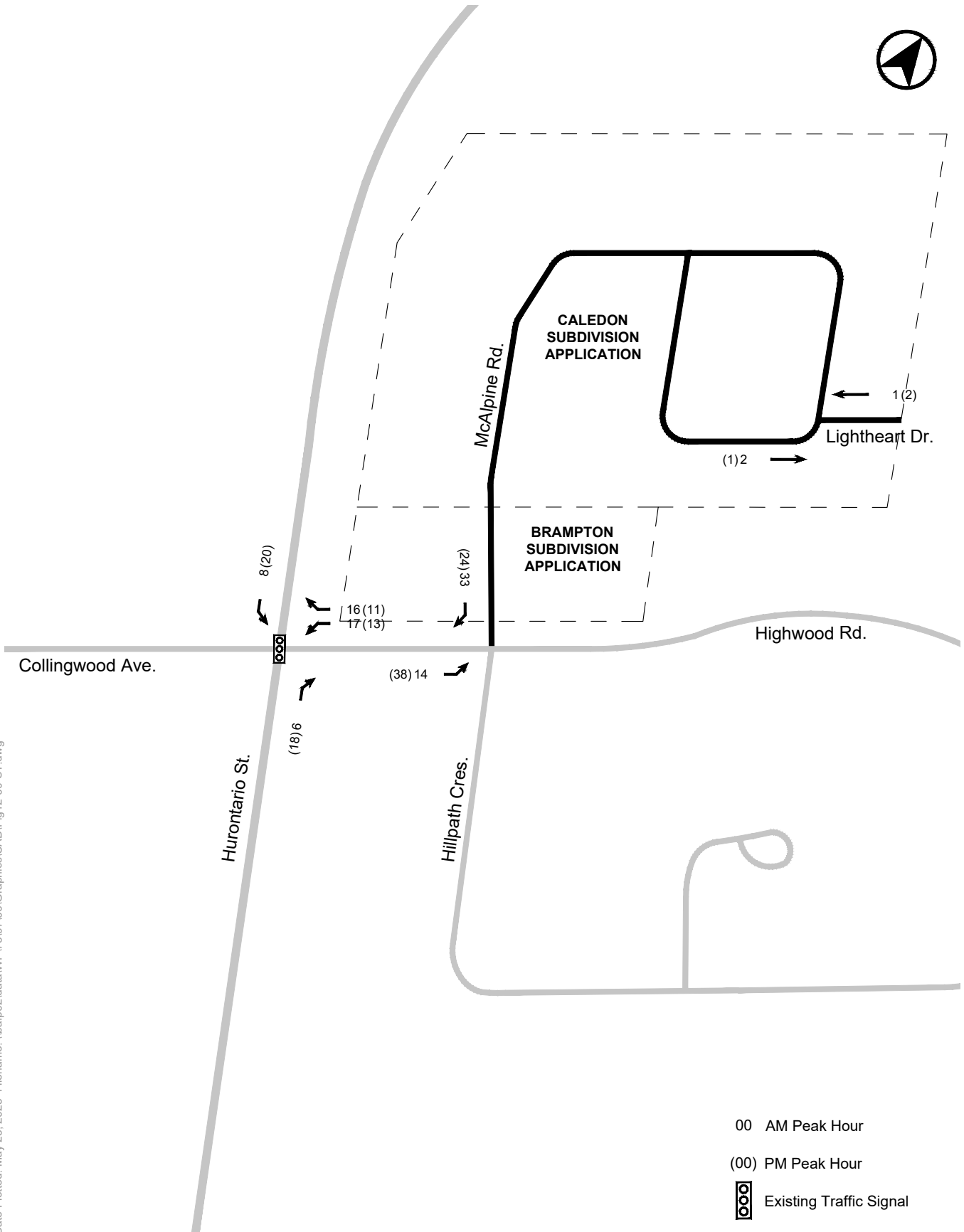

Date Plotted: May 25, 2023 Filename: \\bafp02\data\WPY75197106\Graphics\CAD\Fig12-00-ST.dwg

FIGURE 13 SITE TRAFFIC VOLUMES

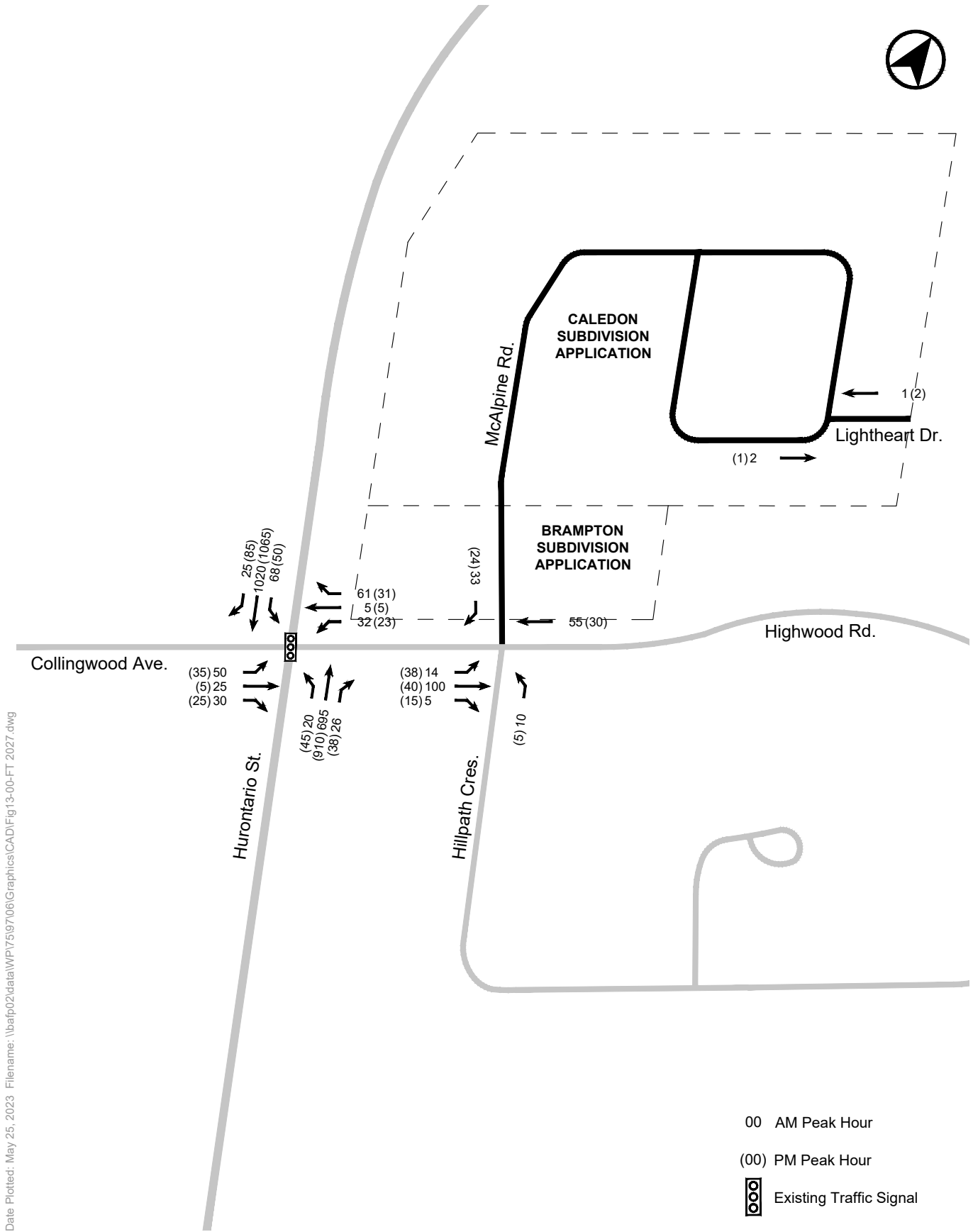

Date Plotted: May 25, 2023 Filename: \\ba\p02\data\WPV75197106\Graphics\CAD\Fig13-00-FT 2027.dwg

FIGURE 14 FUTURE TOTAL TRAFFIC VOLUMES (2027)

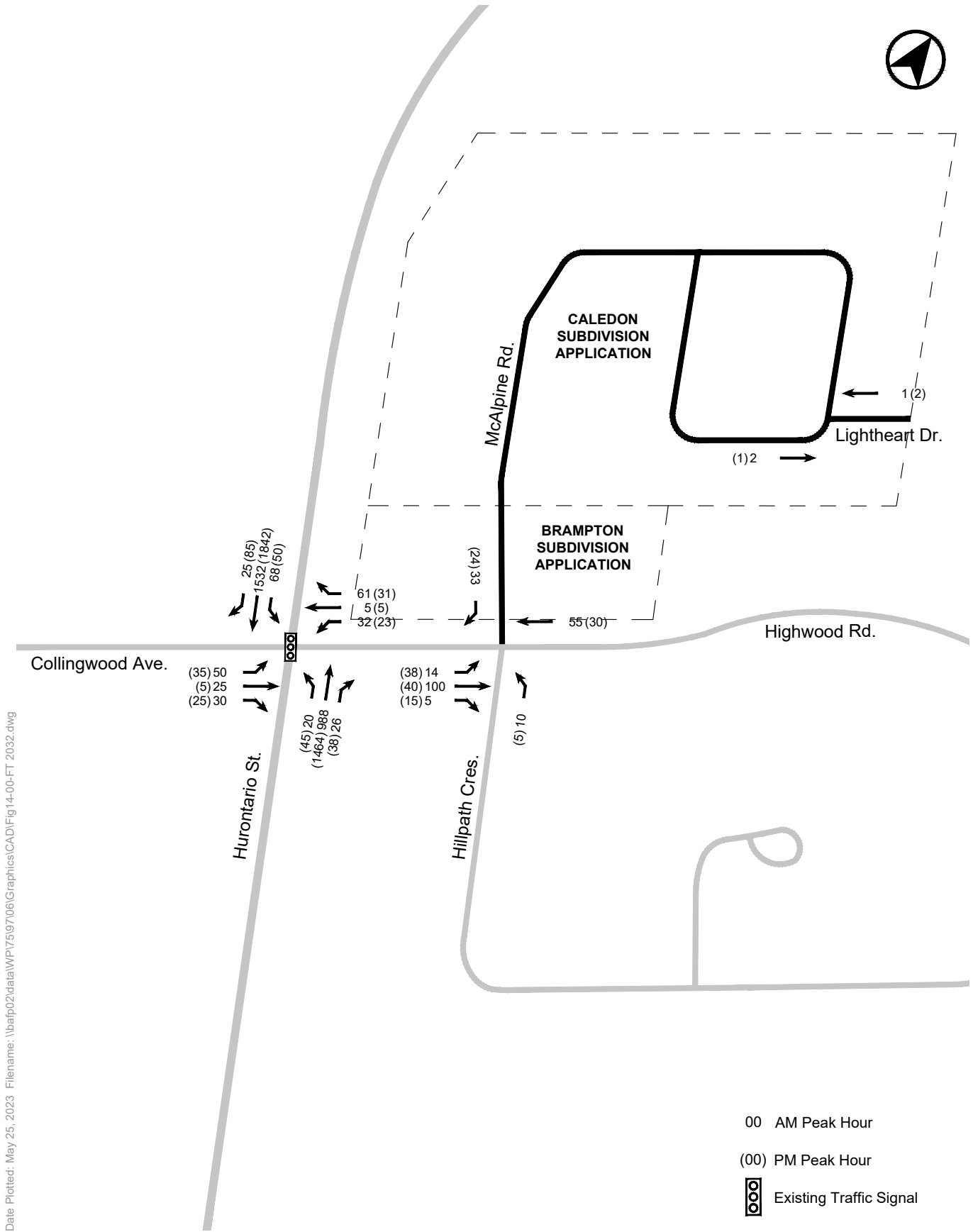

Date Plotted: May 25, 2023 Filename: \\ba\p02\data\WPV75197106\Graphics\CAD\Fig14-00-FT_2032.dwg

FIGURE 15 FUTURE TOTAL TRAFFIC VOLUMES (2032)

8.0 VEHICLE TRAFFIC OPERATIONS ANALYSIS

8.1 ANALYSIS METHODOLOGY

Traffic operations analyses have been undertaken at the area intersections using standard capacity analysis procedures as follows.

Signalized Intersections:

Analyses undertaken at intersections operating under traffic signal control have been undertaken using the methodologies and procedures outlined in the Highway Capacity Manual (HCM) 2000 and in accordance with the Region of Peel's guidelines for analyses undertaken using Synchro 11 software. The product of the signalized intersection evaluation is an intersection performance index (volume to capacity ratio or v/c), where a v/c index of 1.00 indicates 'at or near capacity' conditions.

Unsignalized Intersections:

Unsignalized intersection analyses have been carried out using standard capacity procedures for intersections operating under "Two-way" and "All-Way" STOP control and in accordance with the methodologies outlined in the Highway Capacity Manual 2000 (HCM 2000).

The product of these analyses is a level of service (LOS) designation, ranging from LOS of A to F; which provides a relative indication of the level of delay experienced by motorists completing a turning manoeuvre at an intersection. LOS A represents conditions under which motorists would experience little delay and LOS F reflects conditions where more extended delays can be expected.

HCM level of service (LOS) criteria for unsignalized intersections are as follows:

- LOS A: Control Delay \leq 10s
- LOS B: $10s <$ Control Delay \leq 15s
- LOS C: $15s <$ Control Delay \leq 25s
- LOS D: $25s <$ Control Delay \leq 35s
- LOS E: $35s <$ Control Delay \leq 50s
- LOS F: Control Delay $>$ 50s

Queue Analysis Methodology

Given the limitations of the Synchro 11 software, a microsimulation model was developed using SimTraffic 11 to assess the impacts of the proposed development and determine whether the site traffic generated by the proposed development could be appropriately accommodated without undue impacts on the future road network.

8.2 NETWORK-WIDE PARAMETERS

Key analysis parameters were assumed based on requirements contained in the Region of Peel's *Regional Guidelines for Using Synchro* (December 2010), summarized as follows:

Network Assumptions

The existing area road network lane configuration and traffic control are illustrated in **Figure 4**. The existing area road network lane configuration and traffic control were maintained throughout all scenarios analyzed.

As discussed in **Section 4.1.2**, The McLaughlin Road Class EA identifies the geometric improvements for the Hurontario Street / Valleywood Boulevard Interchange and the construction of a new east-west corridor (“Spine Road”) that extends from Chinguacousy Road to Hurontario Street and connects to the interchange, **Figure 9**. These improvements are expected to take place as part of the Mayfield West Phase 2 Secondary Plan. The new intersection of Hurontario Street and Spine Road would be constructed approximately 250 metres north of Highwood Road. It is noted that access to and from the proposed development is not dependent on the implementation of these modifications.

Existing Signal Timing

Existing signal timings, phasing plans, and cycle lengths were obtained from the City of Brampton and the Region of Peel. Existing signal timings adopted as the basis for the traffic operations analyses are provided in **Appendix I**.

Future Signal Timing

Existing signal timings were maintained during the analysis of future conditions.

Base Saturation Flow Rates

The Region of Peel’s *Regional Guidelines for Using Synchro* (December 2010) specifies a base saturation flow rate of 1,900 vehicles per hour of green time per lane (vphgpl) for signalized and unsignalized intersections. These default rates were adopted in the analysis of the proposed development.

Heavy Vehicle Assumptions

Heavy and medium truck percentages incorporated into the analysis were based on information provided as part of intersection turning movement counts.

Lost Time Adjustments

The Region of Peel’s *Regional Guidelines for Using Synchro* (December 2010) specifies a base lost time adjustment factor of 0.0 seconds (i.e. a total loss time per phase equal to the amber plus all-red time). This default value was adopted in the analysis.

Peak Hour Factors

The Region of Peel’s *Regional Guidelines for Using Synchro* (December 2010) specifies a based peak hour factor (PHF) of 1.00 for all movement on all approaches at all intersections.

Lane Utilization Factors

Under existing conditions, default Synchro lane utilization factors (LUF) was adopted, which take into consideration the distribution of individual lane usage within each movement group.

8.3 SIGNALIZED INTERSECTION ANALYSIS RESULTS

Traffic operations analysis results and discussion for the signalized intersection of Hurontario Street & Collingwood Avenue / Highwood Road under existing, future background and future total conditions are summarized in **Table 15**. Detailed capacity analysis reports are provided in **Appendix J**.

TABLE 15 HURONTARIO STREET & COLLINGWOOD AVENUE / HIGHWOOD ROAD CAPACITY ANALYSIS RESULTS

Lane Group	Existing		Future Background (2027)		Future Total (2027)		Future Background (2032)		Future Total (2032)	
	v/c	LOS	v/c	LOS	v/c	LOS	v/c	LOS	v/c	LOS
EBL	0.38 (0.32)	C (C)	0.38 (0.32)	C (C)	0.38 (0.32)	C (C)	0.38 (0.32)	C (C)	0.38 (0.32)	C (C)
EBTR	0.16 (0.06)	C (C)	0.16 (0.06)	C (C)	0.16 (0.06)	C (C)	0.16 (0.13)	C (C)	0.16 (0.13)	C (C)
WBL	0.11 (0.09)	C (C)	0.11 (0.09)	C (C)	0.24 (0.20)	C (C)	0.11 (0.09)	C (C)	0.24 (0.20)	C (C)
WBTR	0.06 (0.06)	C (C)	0.06 (0.06)	C (C)	0.07 (0.07)	C (C)	0.06 (0.06)	C (C)	0.07 (0.07)	C (C)
NBL	0.05 (0.11)	A (A)	0.06 (0.13)	A (A)	0.06 (0.13)	A (A)	0.12 (0.37)	A (B)	0.12 (0.38)	A (B)
NBT	0.26 (0.31)	A (A)	0.30 (0.35)	A (A)	0.30 (0.36)	A (A)	0.42 (0.56)	A (A)	0.42 (0.57)	A (A)
SBL	0.11 (0.06)	A (A)	0.12 (0.07)	A (A)	0.14 (0.12)	A (A)	0.17 (0.15)	A (A)	0.19 (0.25)	A (A)
SBT	0.37 (0.36)	A (A)	0.42 (0.40)	A (A)	0.42 (0.40)	A (A)	0.63 (0.70)	A (A)	0.64 (0.70)	A (A)
SBR	0.02 (0.05)	A (A)	0.02 (0.05)	A (A)	0.02 (0.05)	A (A)	0.02 (0.06)	A (A)	0.02 (0.06)	A (A)
Overall	0.38 (0.35)	A (A)	0.42 (0.40)	A (A)	0.42 (0.40)	A (A)	0.60 (0.66)	A (A)	0.60 (0.66)	A (A)

Note

1. 00 (00): Weekday morning peak hour (Weekday afternoon peak hour).

Under existing traffic conditions, the intersection operates within capacity during the weekday morning and afternoon peak hour periods with overall volume-to-capacity (v/c) ratios of 0.38 and 0.35, respectively.

Under the 2027 future background conditions, with the addition of 2027 background traffic, the intersection will continue to operate under acceptable conditions with overall v/c ratios of 0.42 and 0.40 during the morning and afternoon peak hours, respectively. The maximum v/c ratio for any individual movement is 0.42 on the southbound through movement in the weekday morning peak hour.

Under 2027 future total conditions, with the addition of site-related traffic, the intersection will continue to operate under acceptable conditions with overall v/c ratios of 0.42 and 0.40 during the morning and afternoon peak

hours, respectively. The maximum v/c ratio for any individual movement is 0.42 on the southbound through movement in the weekday morning peak hour.

Under the 2032 future background conditions, with the addition of 2032 background traffic, the intersection will continue to operate under acceptable conditions with overall v/c ratios of 0.60 and 0.66 during the morning and afternoon peak hours, respectively. The maximum v/c ratio for any individual movement is 0.70 on the southbound through movement in the weekday afternoon peak hour.

Under 2032 future total conditions, with the addition of both site-related and Mayfield West Phase 2 traffic, the intersection will continue to operate under acceptable conditions with overall v/c ratios of 0.60 and 0.66 during the morning and afternoon peak hours, respectively. The maximum v/c ratio for any individual movement is 0.70 on the southbound through movement in the weekday afternoon peak hour.

The addition of site traffic has minimal impacts on the overall intersection operations. All individual movements and the intersection overall are expected to operate within the capacity and at acceptable levels of service.

8.4 UNSIGNALIZED INTERSECTION ANALYSIS RESULTS

The results of the unsignalized intersection traffic operations analyses undertaken for Highwood Road & Hillpath Crescent / McAlpine Road are summarized in **Table 16**. Detailed Synchro analysis worksheets are provided in **Appendix J**.

TABLE 16 HIGHWOOD ROAD & HILLPATH CRESCENT / McALPINE ROAD ANALYSIS RESULTS

Lane Group	Existing		Future Background (2027)		Future Total (2027)		Future Background (2032)		Future Total (2032)	
	Delay	LOS	Delay	LOS	Delay	LOS	Delay	LOS	Delay	LOS
EBTLR	0.0 (0.0)	A (A)	0.0 (0.0)	A (A)	0.9 (3.1)	A (A)	0.0 (0.0)	A (A)	0.9 (3.1)	A (A)
WBTLR	0.0 (0.0)	A (A)	0.0 (0.0)	A (A)	0.0 (0.0)	A (A)	0.0 (0.0)	A (A)	0.0 (0.0)	A (A)
NBTLR	9.5 (9.1)	A (A)	9.5 (9.1)	A (A)	10.1 (10.0)	B (B)	9.5 (9.1)	A (A)	10.1 (10.0)	B (B)
SBTLR	0.0 (0.0)	A (A)	0.0 (0.0)	A (A)	8.7 (8.5)	A (A)	0.0 (0.0)	A (A)	8.7 (8.5)	A (A)

Notes:

1. 00 (00): Weekday morning peak hour (Weekday afternoon peak hour).
2. Control delay calculated in seconds

The addition of site traffic has minimal impacts on the overall intersection operations. All individual movements and the intersection overall are expected to operate within the capacity and at acceptable levels of service.

8.5 QUEUE ANALYSIS RESULTS

Vehicle queue lengths of study area intersections were established using the SimTraffic microsimulation model. The resulting queues and available storage lengths are summarized in **Table 15**. Detailed SimTraffic reports are attached in **Appendix K**.

TABLE 17 FUTURE TOTAL SIMTRAFFIC QUEUE ANALYSIS RESULTS

Intersection	Lane	Storage Length (m)	95 th Percentile Queue (m)	
			Future Total (2027)	Future Total (2032)
Hurontario St & Collingwood Ave / Highwood Rd ²	EBL	30	22 (13)	27 (15)
	EBTR	30	25 (12)	18 (22)
	WBL	30	19 (15)	19 (15)
	WBTR	30	18 (17)	17 (21)
	NBL	120	12 (11)	13 (26)
	NBT	120	31 (25)	34 (81)
	NBTR	120	23 (22)	34 (72)
	SBL	55 / 250	21 (14)	31 (19)
	SBT	85 / 250	43 (41)	61 (78)
	SBR	40 / 250	6 (8)	6 (29)
Highwood Rd & Hillpath Cres / McAlpine Rd	EBLTR	--	6 (4)	3 (0)
	WBLTR	--	0 (0)	0 (0)
	NBLTR	--	11 (9)	9 (10)
	SBLTR	--	12 (11)	12 (11)

Note

- 00 (00): Weekday morning peak hour (Weekday afternoon peak hour).
- Provided storage lengths at Hurontario St / Collingwood Ave-Highwood Rd are measured as follows:
 - EBTR: from the eastbound stop bar at Hurontario St to the first private driveway west of Hurontario St.
 - WBTR: from the westbound stop bar at Hurontario St to the first private driveway east of Hurontario St.
 - NBT/NBTR: from the northbound stop bar at Collingwood Ave-Highwood Rd to the first private driveway south of Collingwood Ave-Highwood Rd.
 - SBT (2027): from the southbound stop bar at Collingwood Ave-Highwood Rd to the Hutchinson Farm Ln.
 - SBT (2032): from the southbound stop bar at Collingwood Ave-Highwood Rd to Spine Road.

All 50th and 95th percentile queue lengths are well-contained within their respective storage lengths during both peak hours under all conditions. The addition of site traffic has minimal impacts on the overall intersection operations.

8.6 SUMMARY

Based on the analysis conducted by BA Group, the forecast vehicle site traffic generated by the proposed development will have minimal impacts on the overall operation of the network signalized and unsignalized intersections. All of the study area signalized and unsignalized intersections can acceptably accommodate site-related traffic activity and will continue to operate within the capacity and at acceptable levels of service under future conditions without the need for improvements.

APPENDICES

Appendix A
Reduced Scale Architectural Plans

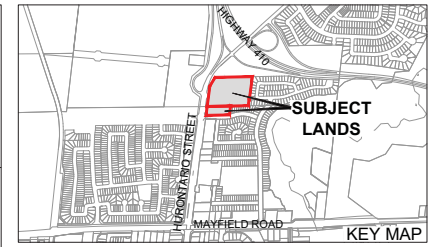
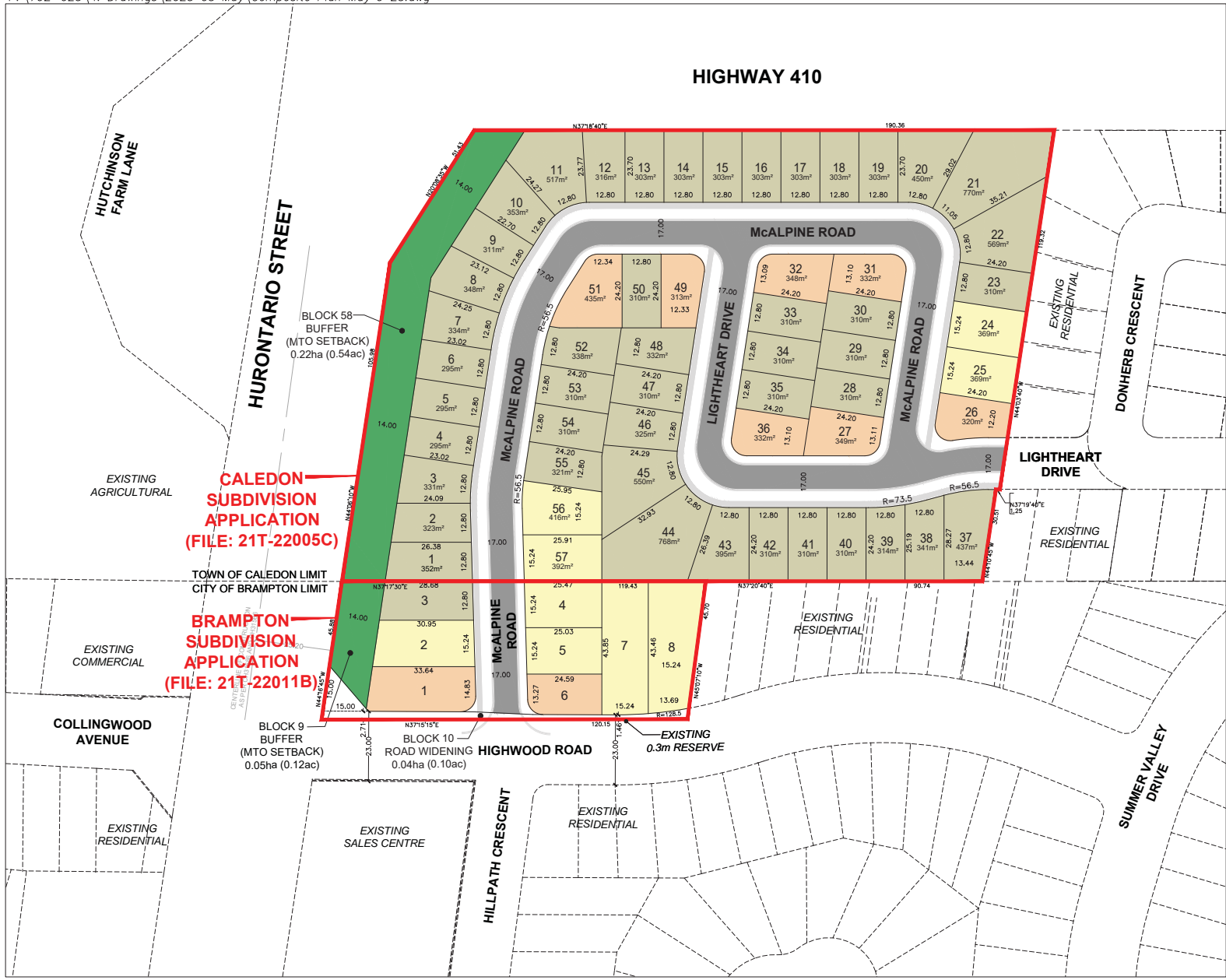

COMPOSITE PLAN
ARGO SUMMER VALLEY LIMITED

PART OF LOT 18, CONCESSION 1, E.H.S.
 (GEOGRAPHIC TOWNSHIP OF CHINGUACOUSY)
 CITY OF BRAMPTON
 REGIONAL MUNICIPALITY OF PEEL
 AND
 PART OF LOT 19, CONCESSION 1, E.H.S.
 (GEOGRAPHIC TOWNSHIP OF CHINGUACOUSY, COUNTY OF PEEL)
 TOWN OF CALEDON
 REGIONAL MUNICIPALITY OF PEEL

LAND USE SCHEDULE - CITY OF BRAMPTON

LAND USE	LOTS / BLOCKS	AREA (ha)	AREA (ac)	UNITS	DENSITY (UPHA)
DETACHED - 12.20m (40')	1-8	0.08	0.20	2	25.00
DETACHED - 12.80m (42')		0.04	0.10	1	25.00
DETACHED - 15.24m (50')		0.26	0.64	5	19.23
OPEN SPACE (MTO SETBACK)	9	0.05	0.12		
ROAD WIDENING	10	0.04	0.10		
17.0m LOCAL R.O.W. (LENGTH: 43m)		0.07	0.17		
TOTAL	10	0.64	1.33	8	21.05

LAND USE SCHEDULE - TOWN OF CALEDON

LAND USE	LOTS / BLOCKS	AREA (ha)	AREA (ac)	UNITS	DENSITY (UPHA)
DETACHED - 12.20m (40')	1-57	0.24	0.59	7	28.17
DETACHED - 12.80m (42')		1.65	4.08	46	27.88
DETACHED - 15.24m (50')		0.15	0.37	4	26.67
OPEN SPACE (MTO SETBACK)	58	0.22	0.54		
ROAD WIDENING		0.82	2.03		
17.0m LOCAL R.O.W. (LENGTH: 470m)		0.99	2.20		
TOTAL	68	3.08	7.61	57	27.94

LAND USE SCHEDULE - COMBINED

LAND USE	AREA (ha)	AREA (ac)	UNITS	DENSITY (UPHA)
DETACHED - 12.20m (40')	0.32	0.79	9	28.13
DETACHED - 12.80m (42')	1.69	4.18	47	27.81
DETACHED - 15.24m (50')	0.41	1.01	9	21.95
OPEN SPACE (MTO SETBACK)	0.27	0.67		
ROAD WIDENING	0.94	2.30		
17.0m LOCAL R.O.W. (LENGTH: 513m)	0.89	2.20		
TOTAL	3.62	8.95	65	26.86



SCALE 1:1,250
 MAY 9, 2023



Appendix B
Parking Allocation Plan

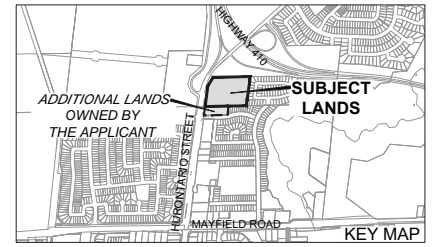
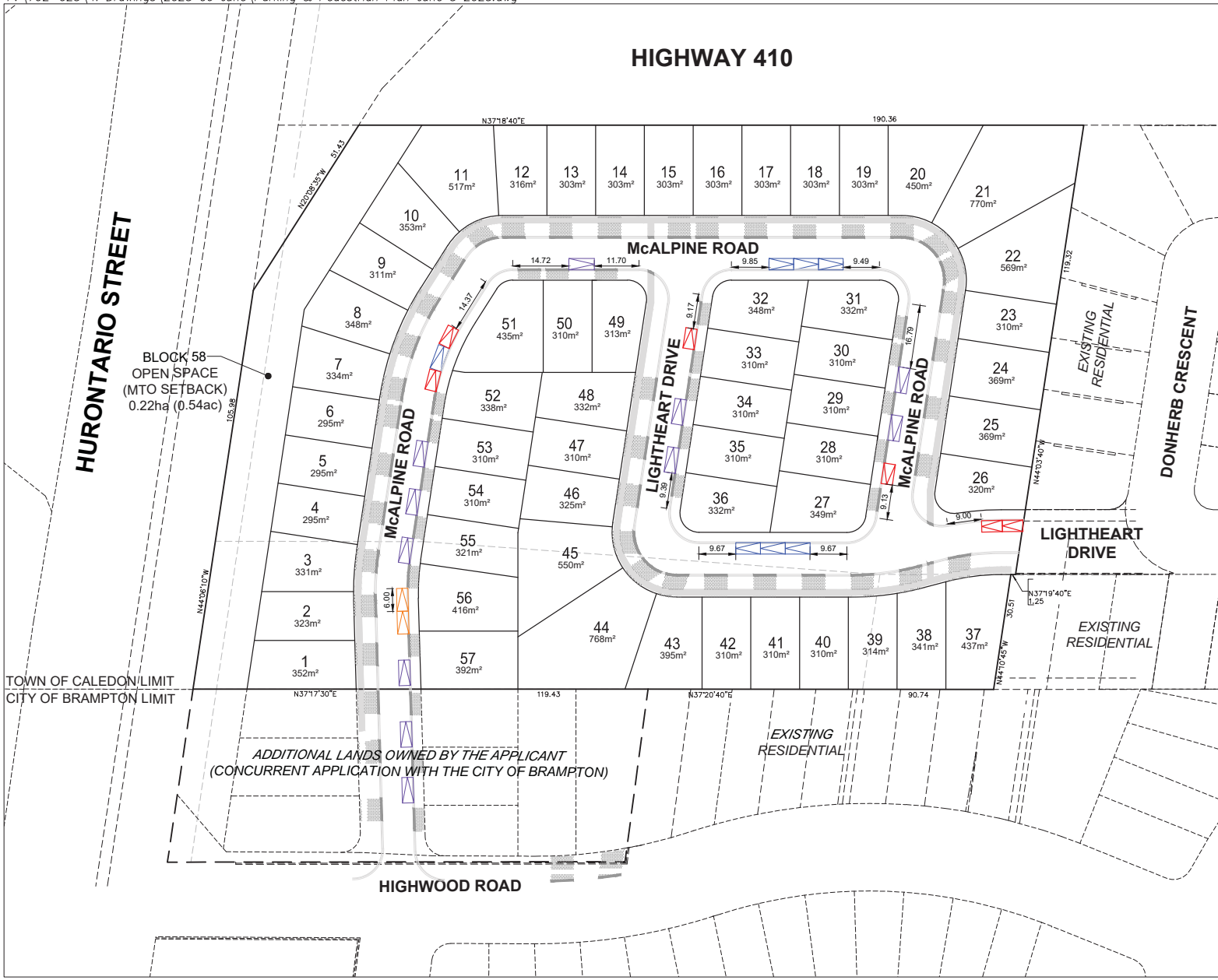

PARKING & PEDESTRIAN CIRCULATION PLAN
ARGO SUMMER VALLEY LIMITED
FILE # 21T-22005C

PART OF LOT 19, CONCESSION 1, E.H.S.
 (GEOGRAPHIC TOWNSHIP OF CHINGLIACOUSY, COUNTY OF PEEL)
 TOWN OF CALEDON
 REGIONAL MUNICIPALITY OF PEEL

DEVELOPMENT STATISTICS

TOTAL NUMBER OF UNITS:	57
TOTAL ON-STREET PARKING PROVIDED:	24

PARKING STATISTICS

REQUIRED PARKING (57 x 3.5):	199.5
1 CAR GARAGE PARKING (28 x 3):	84
2 CAR GARAGE PARKING(29 x 4):	116
ON-STREET PARKING:	24
TOTAL:	224

LEGEND

- POTENTIAL SIDEWALK LOCATIONS
- CONCEPTUAL PAVEMENT / DRIVEWAYS
- SINGLE ON-STREET PARKING (3.0m x 5.4m)
- TANDEM ON-STREET PARKING (3.0m x 6.5m)
- SINGLE ON-STREET PARKING (3.0m x 6.7m)
- SINGLE ON STREET PARKING 3.0m x 6.0m)

NOTE

9.0m MINIMUM SETBACK FROM INTERSECTIONS FOR ALL ON-STREET PARKING SPACES.



SCALE 1:1,000
 JUNE 5, 2023



Appendix C
Functional Road Design and Vehicle Manoeuvring Diagrams

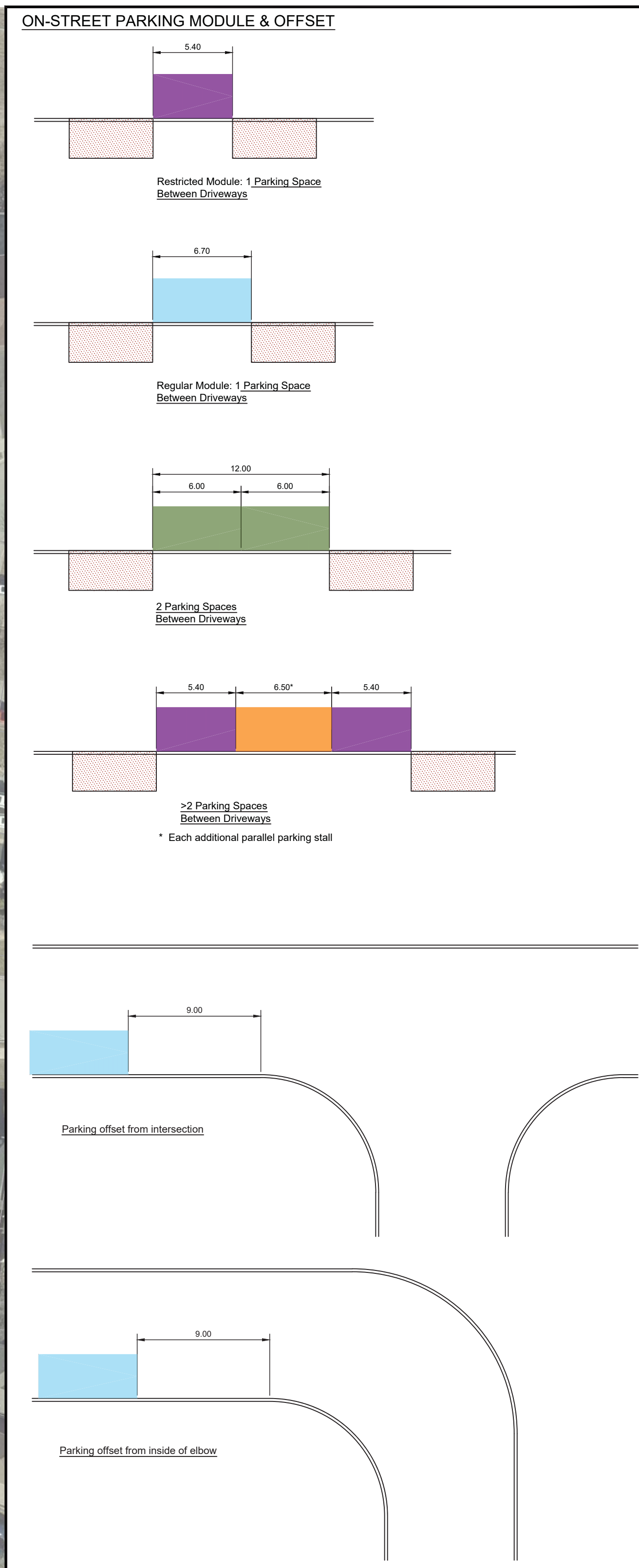
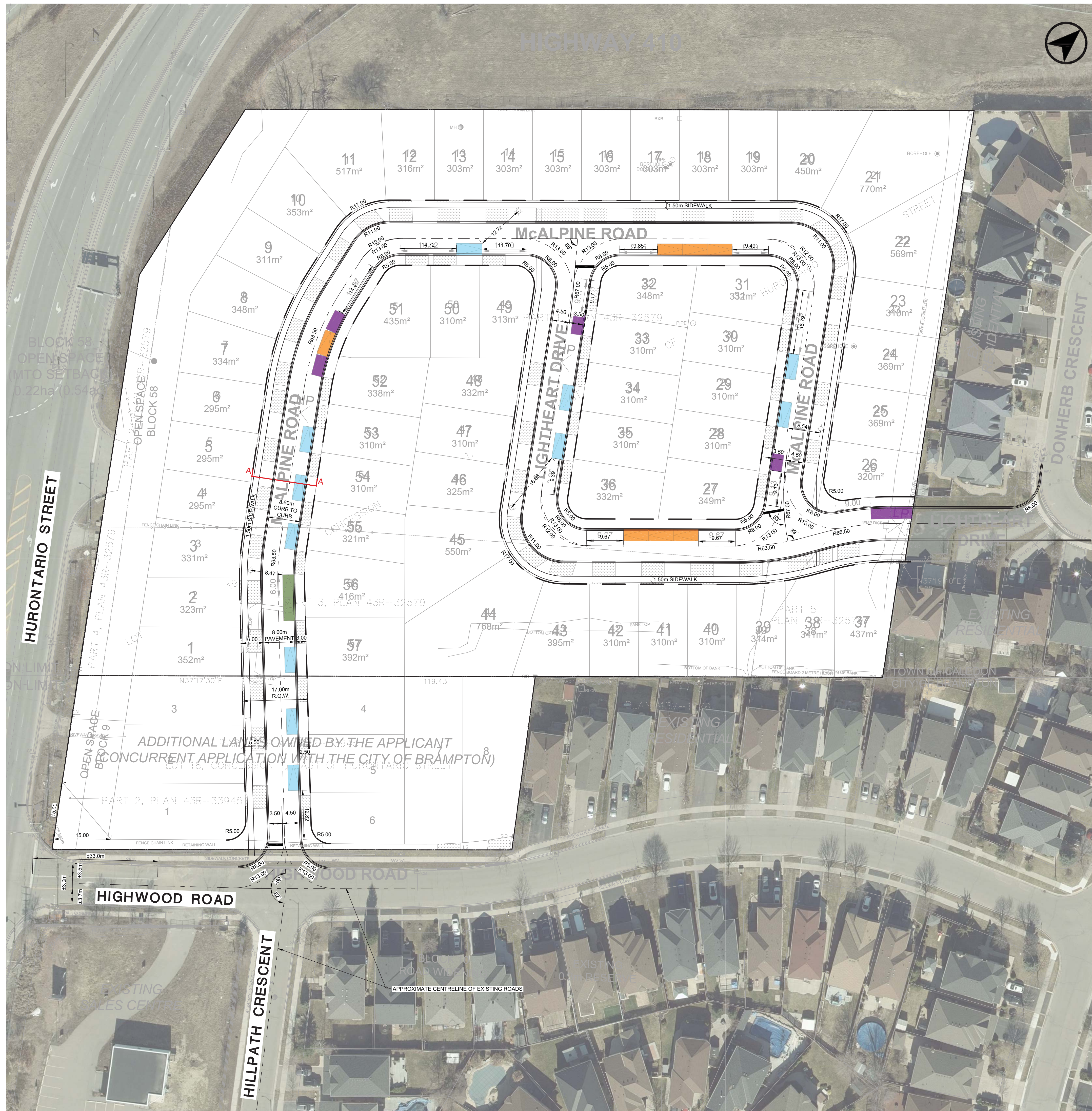

GENERAL NOTES

1. PARKING & PEDESTRIAN CIRCULATION PLAN DATED JUNE 5, 2023, PREPARED BY CSAL
2. PROPOSED DRIVEWAY LAYOUT AND FIRE HYDRANT LOCATION PREPARED BY R.J. BURNSIDE
3. LOCATION OF MAILBOX CANNOT BE DETERMINED AT THIS STAGE, WHICH WILL IMPACT ON-STREET PARKING SPACES.
4. CITY OF BRAMPTON STANDARD #200 HAS BEEN ADOPTED FOR THE DESIGN PURPOSES. THEREFORE, IT IS SUBJECT TO CONFIRMATION OF THE CITY OF BRAMPTON AND TOWN OF CALEDON ENGINEERING TEAMS.
5. THE ROAD ALIGNMENT AND THE SIDEWALK SHOULD TIE INTO HIGHWOOD ROAD.
6. THIS PLAN ILLUSTRATIVE FOR THE PURPOSE OF FUNCTIONAL ROAD PLAN AND SHOWING PARKING ALLOCATION AND SHALL NOT BE RELIED UPON FOR DETAILED DESIGN OR CONSTRUCTION.

LEGEND

- 5.4m PARALLEL PARKING SPACE
- 6.0m PARALLEL PARKING SPACE
- 6.5m PARALLEL PARKING SPACE IN BETWEEN
- 6.7m PARALLEL PARKING SPACE

ON-STREET PARKING SUPPLY - TOWN OF CALEDON

Units	Parking	Ratio (Parking/Unit)
57	24	0.42

ON-STREET PARKING SUPPLY - CITY OF BRAMPTON

Units	Parking	Ratio (Parking/Unit)
8	2	0.25

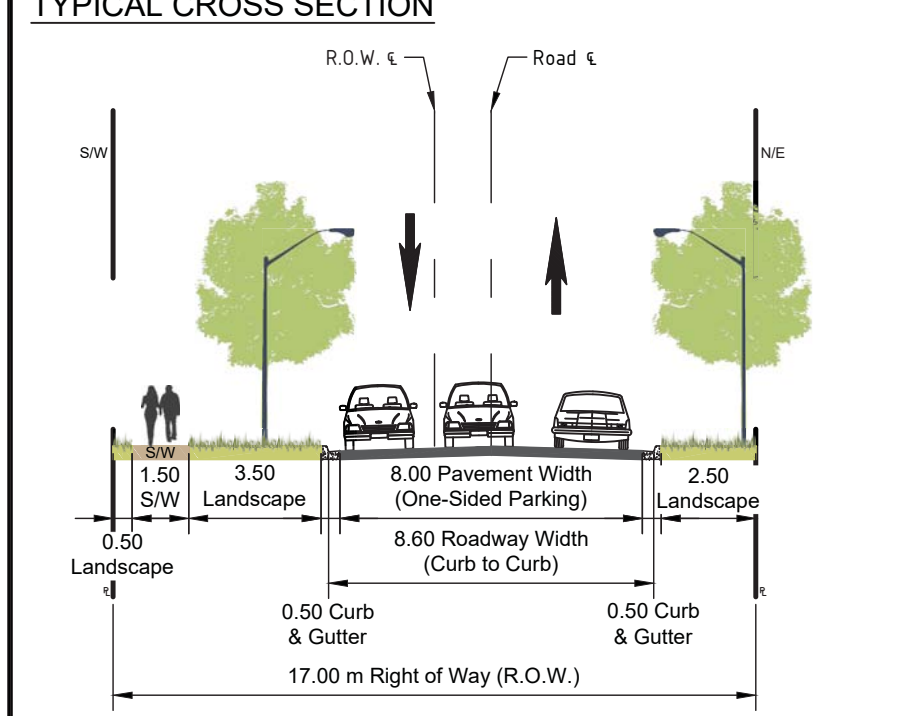

SECTION A-A: Public Street Cross-Section City of Brampton Standard 200 17.0m ROW - 8.0m Pavement Width (8.0m Roadway Width) with 3.0m One-Sided Parking & 1.5m Sidewalk

PRELIMINARY DRAFT FOR DISCUSSION PURPOSES ONLY

01	06-06-23	MA	ISSUED FOR DRAFT PLAN OF SUB-DIVISION
00	MM-DD-YR	INT	REVISION NOTE

BA Group
 BA Consulting Group Ltd.
 300 - 45 St. Clair Ave. W.
 Toronto ON M4V 1K3
 Tel: 416-961-7110
 www.bagroup.com

ARGO SUMMER VALLEY

FUNCTIONAL ROAD PLAN WITH TYPICAL STREET DESIGN ELEMENTS & PARKING ALLOCATION PLAN

Date: June 6, 2023
 Project No.: 7597-06
 Scale: 1:500

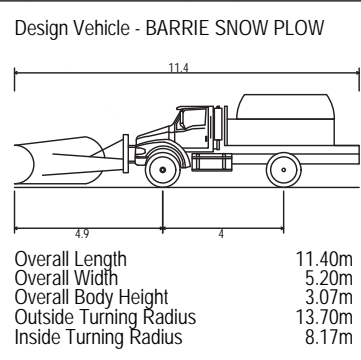
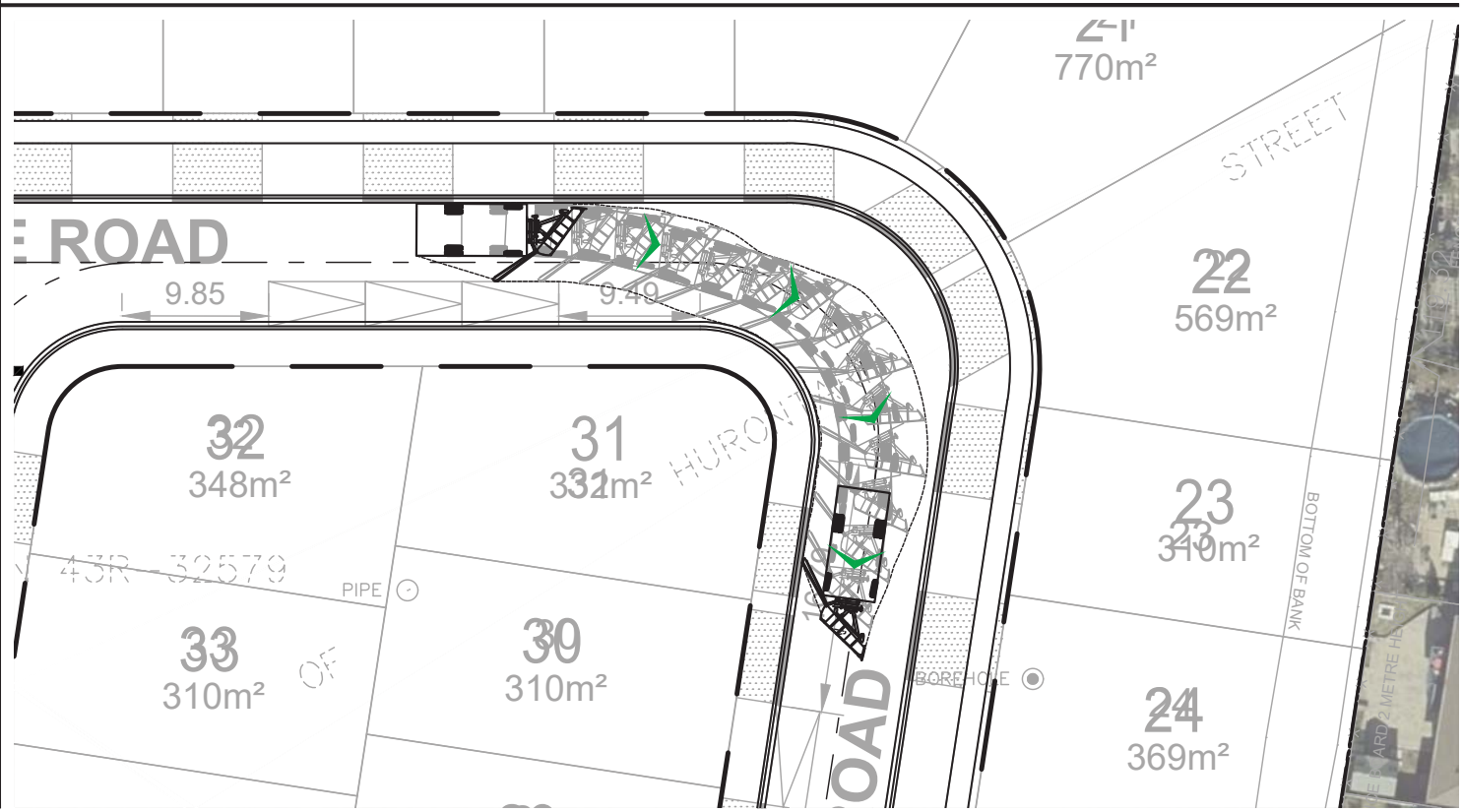
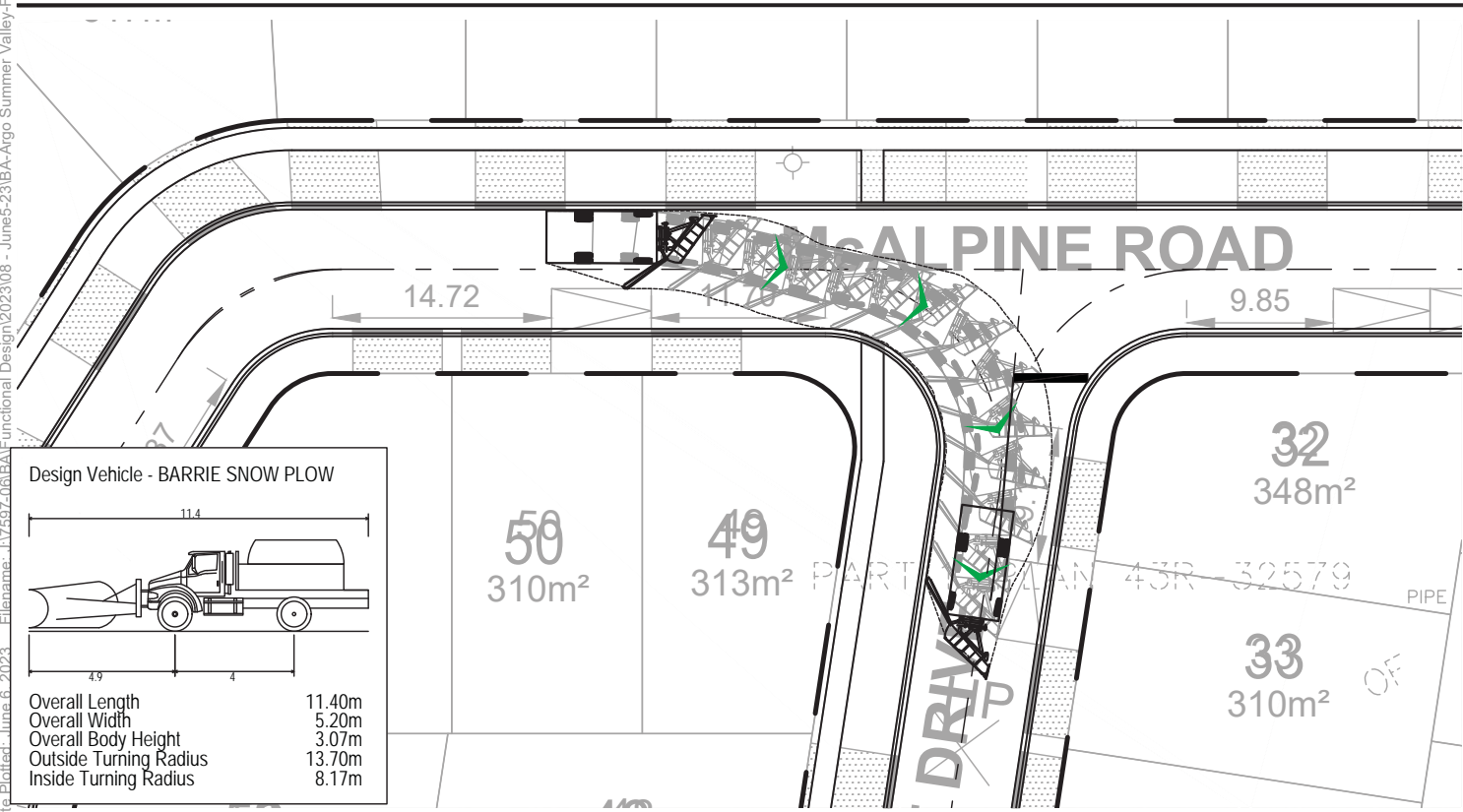
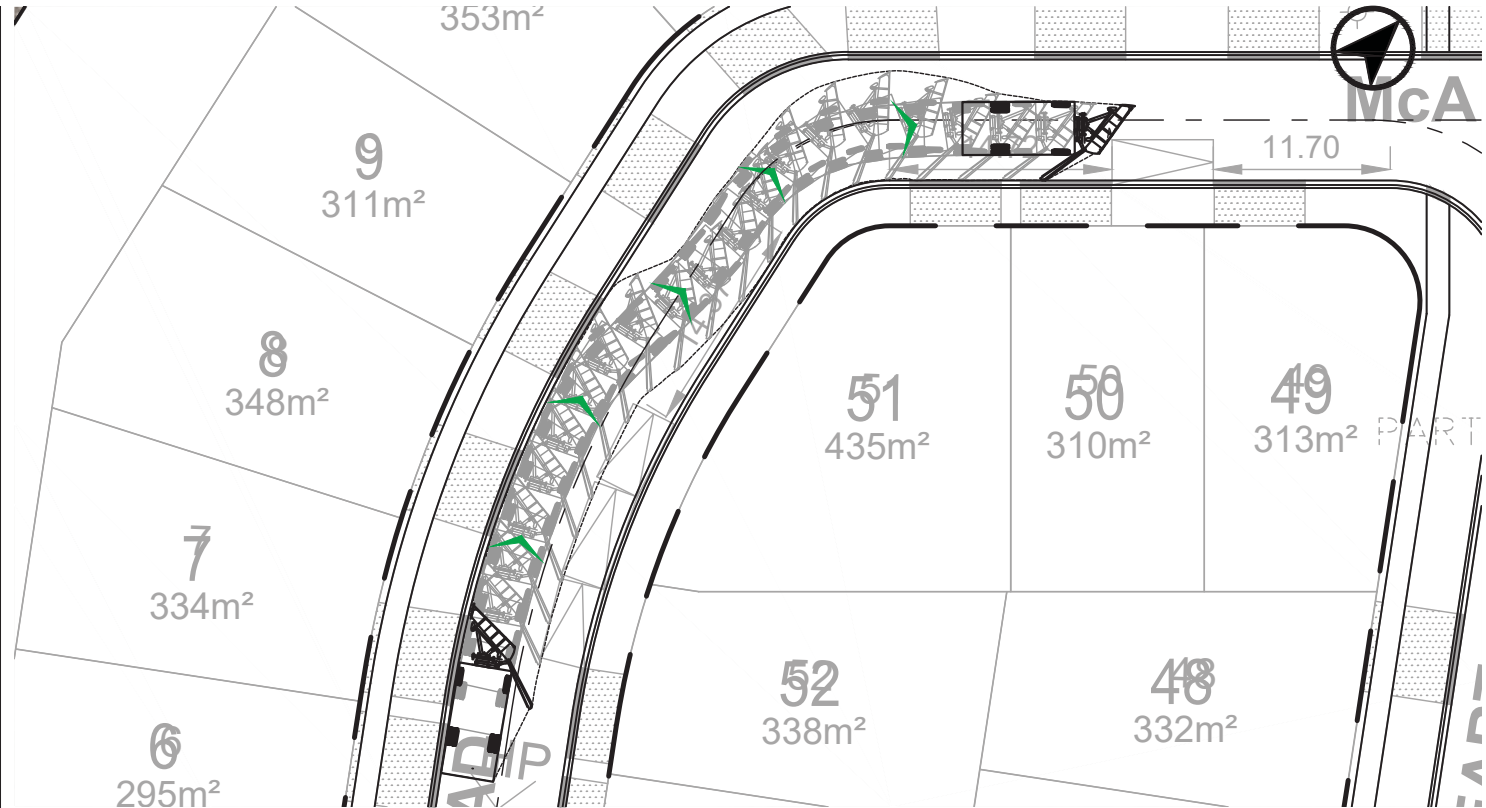
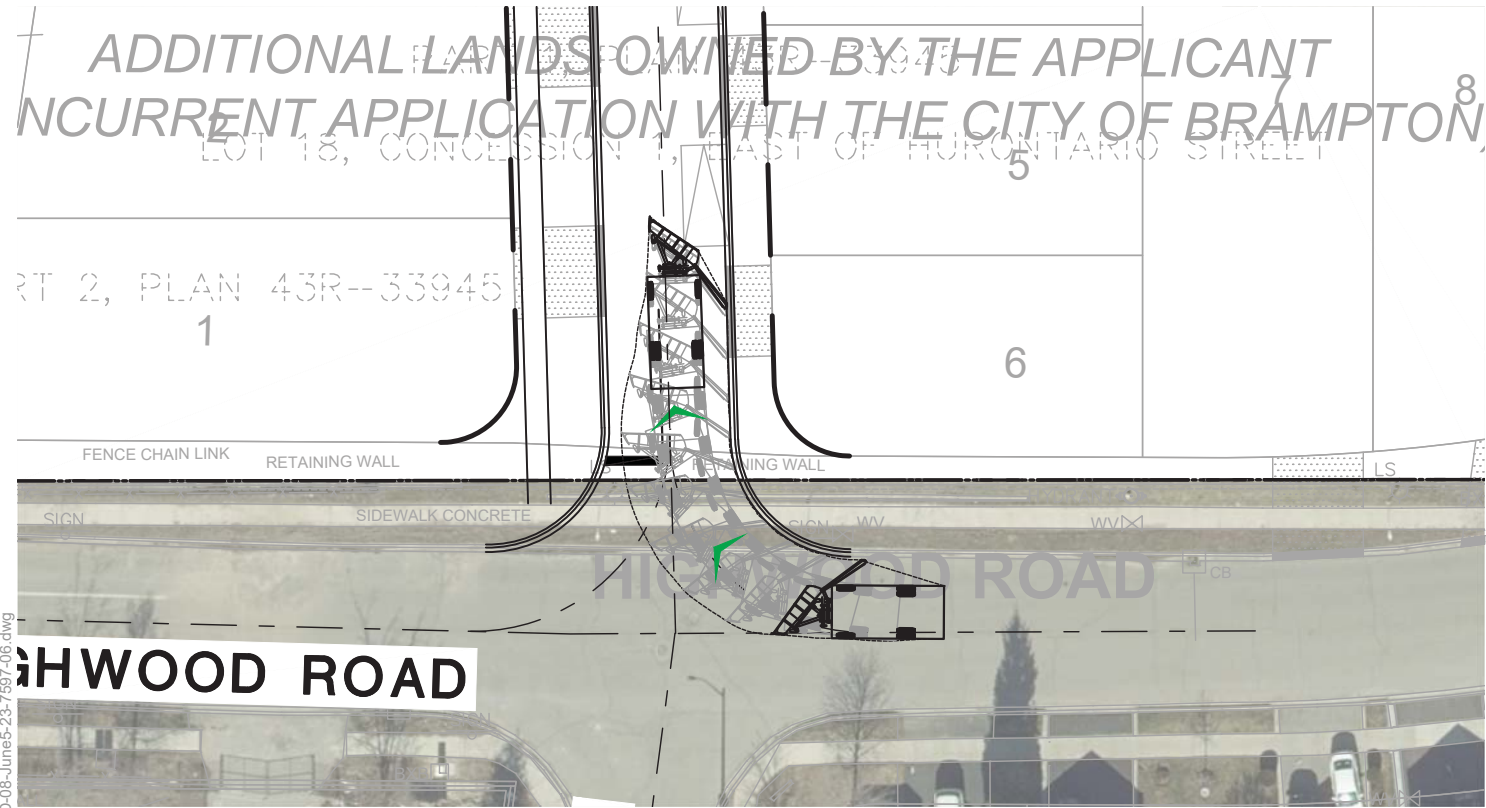

Def: Elcitat: June 6, 2023. Filename: I:\2597\06\BA\Functional Design\202308 - June 5-23\BA-Ago Summer Valley-FD-08-June5-23-7997-06.dwg

	<p align="center">SUMMER VALLEY FUNCTIONAL DESIGN VEHICLE MANOEUVRING DIAGRAMS CITY OF BARRIE SNOW PLOW</p>	Project: SUMMER VALLEY Project No. 7597-06 Date: MAY 9, 2023 Revised: JUNE 6, 2023	Scale 1:500
		Drawing No. VMD-01	

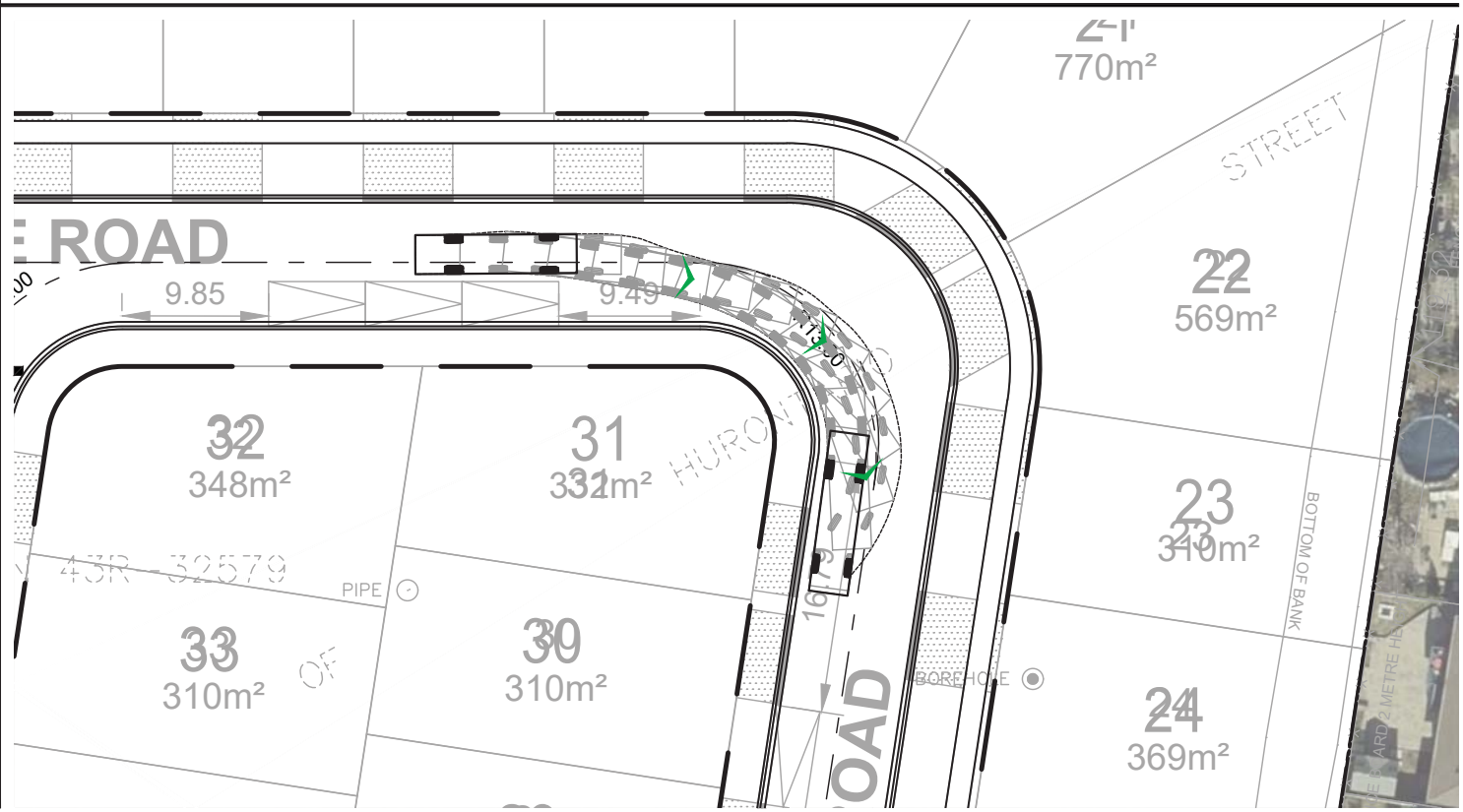
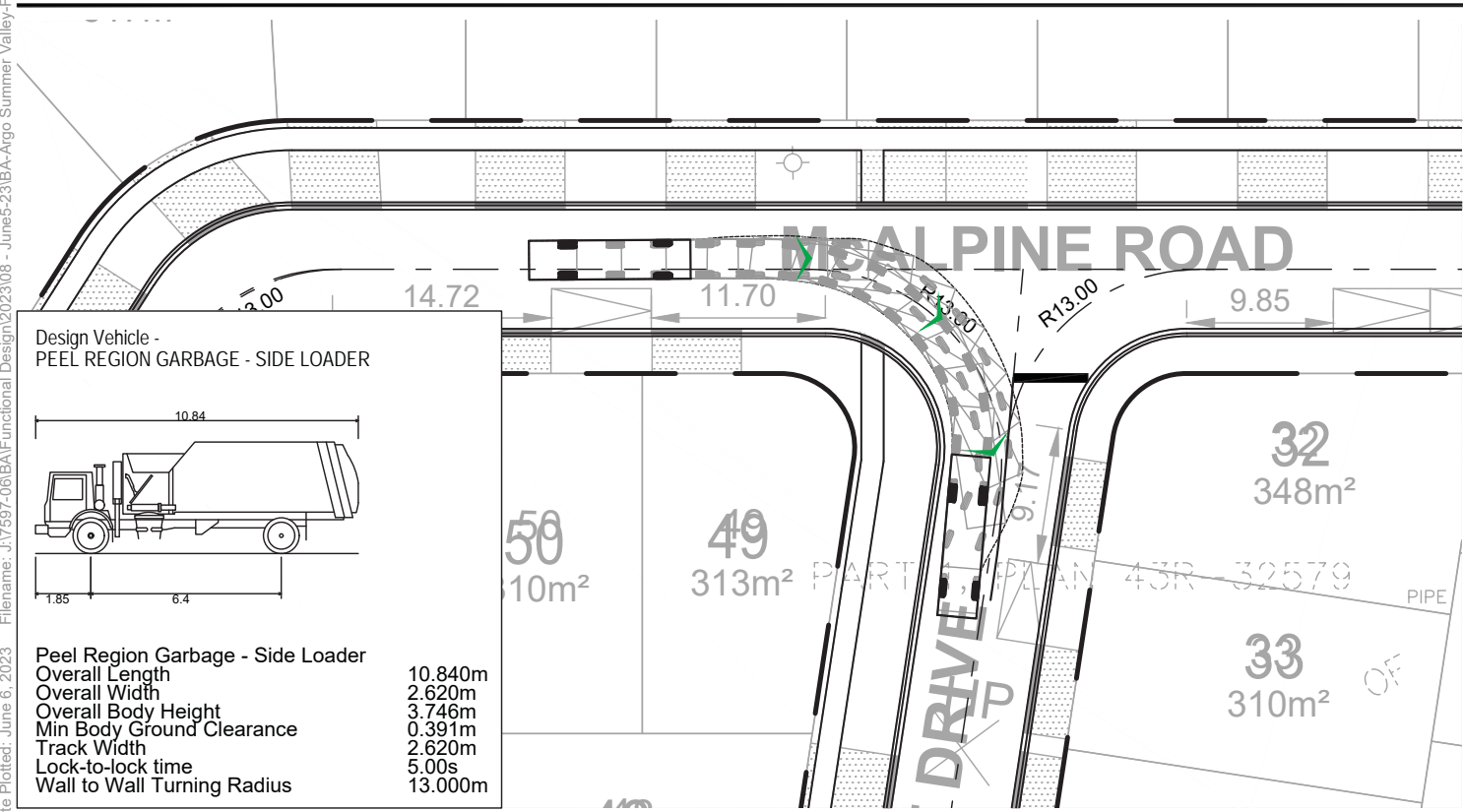
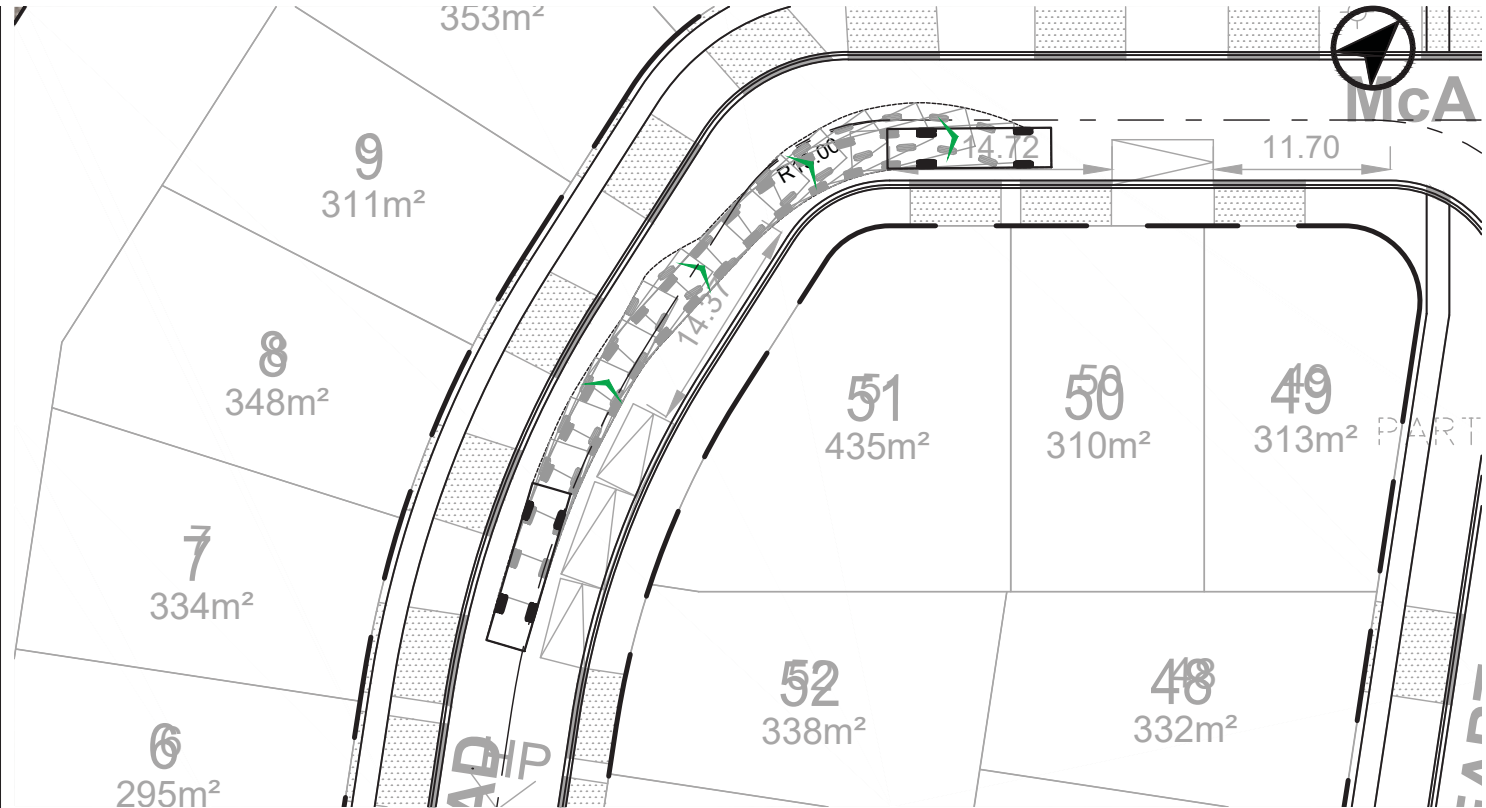
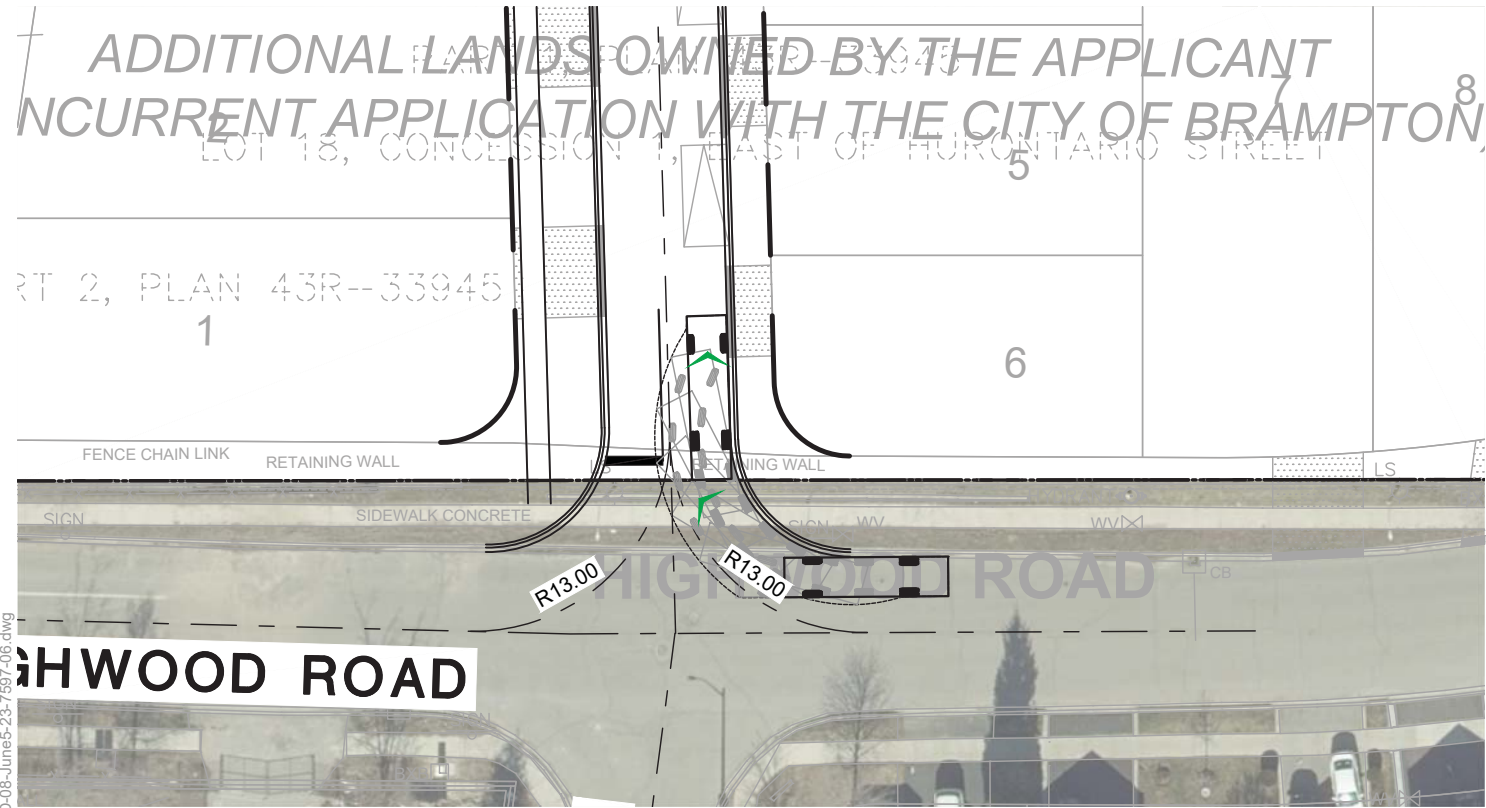

SUMMER VALLEY
 FUNCTIONAL DESIGN
 VEHICLE MANOEUVRING DIAGRAMS
 PEEL REGION SIDE LOADING REFUSE TRUCK



Project: SUMMER VALLEY
 Project No. 7597-06
 Date: MAY 9, 2023
 Revised: JUNE 6, 2023

Scale 1:500

Drawing No. **VMD-02**

Date Plotted: June 6, 2023 File name: J:\7597-06\BA\Functional Design\202308 - June5-23\BA-Ago Summer Valley-FD-08-June5-23-7597-06.dwg

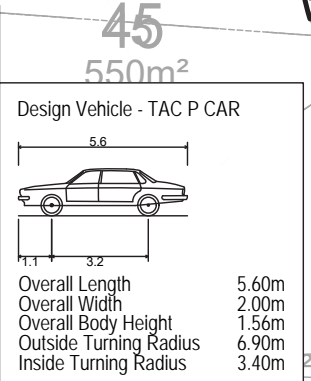
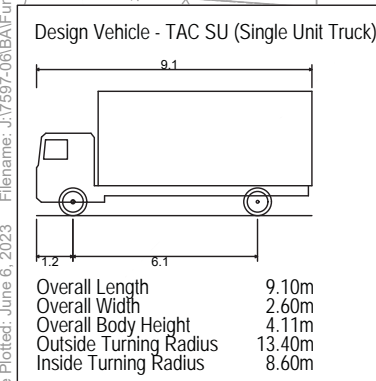
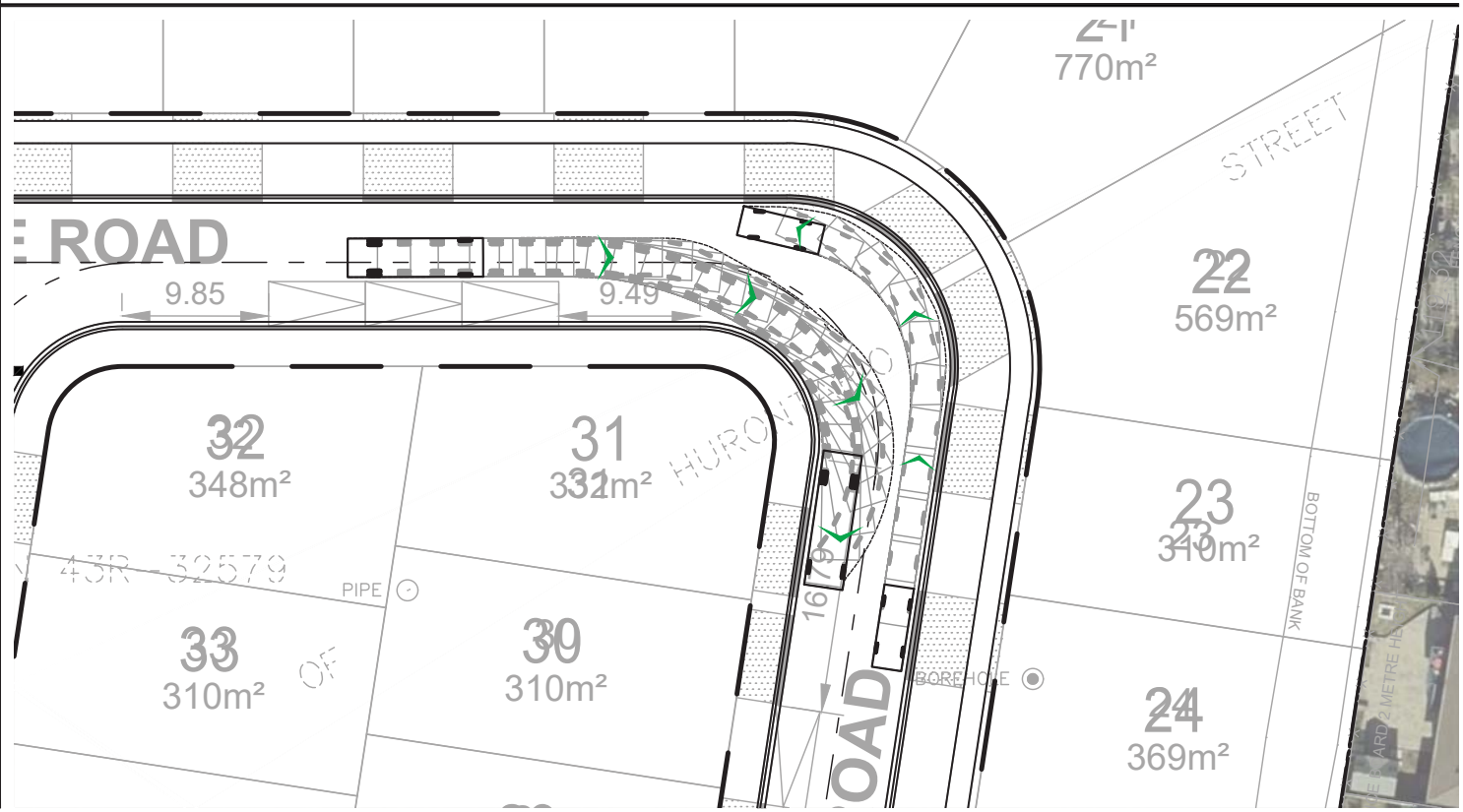
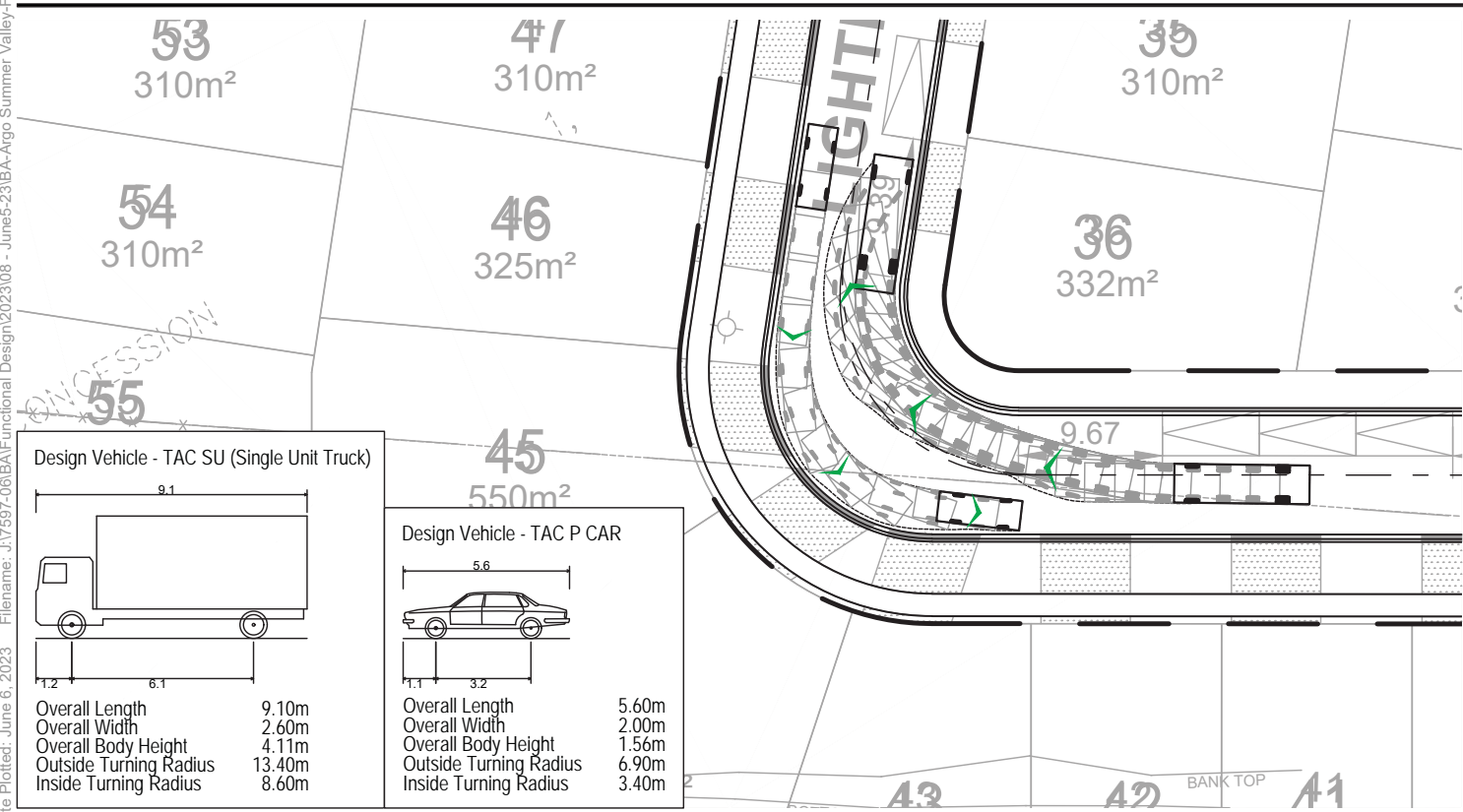
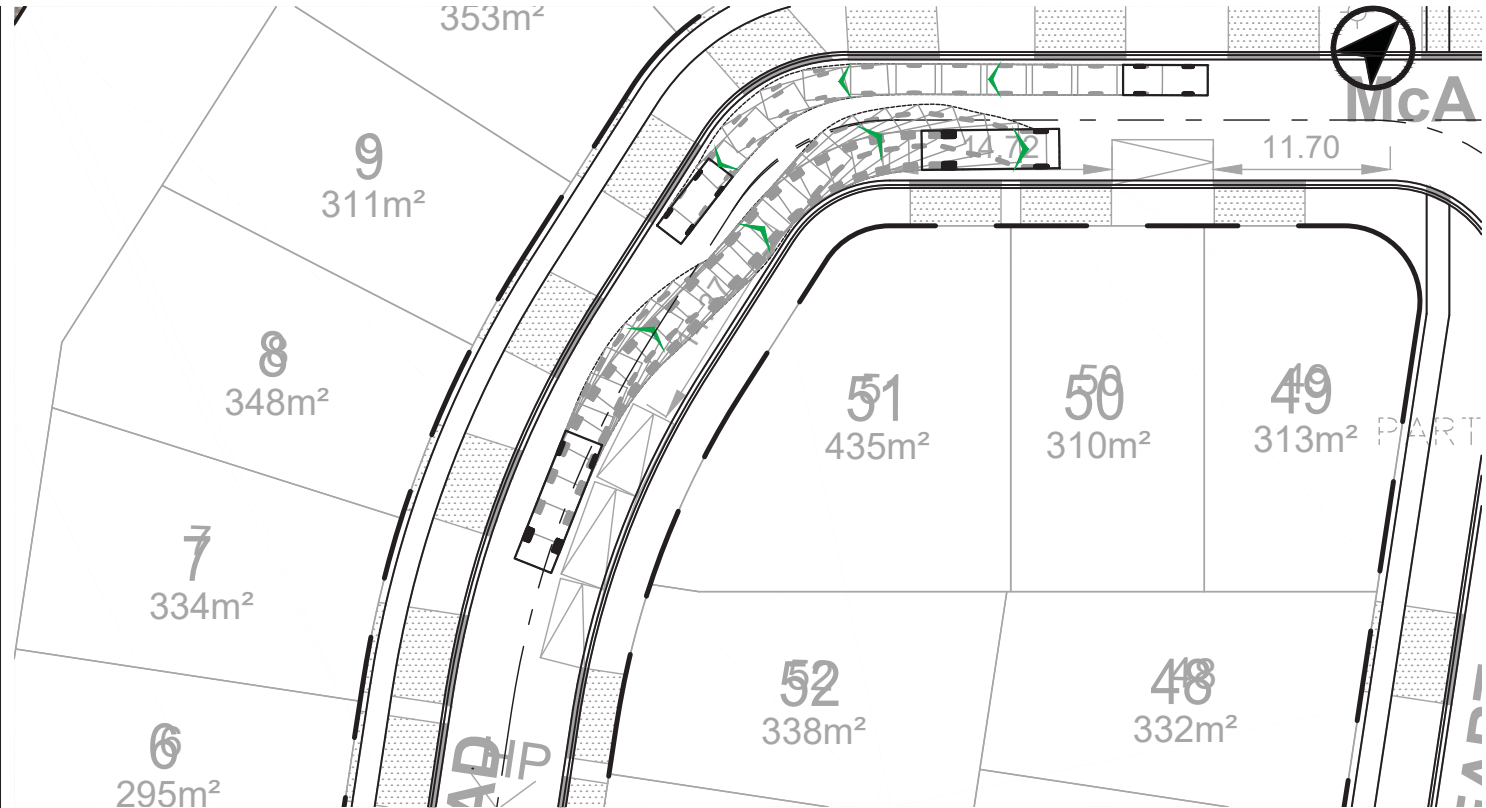
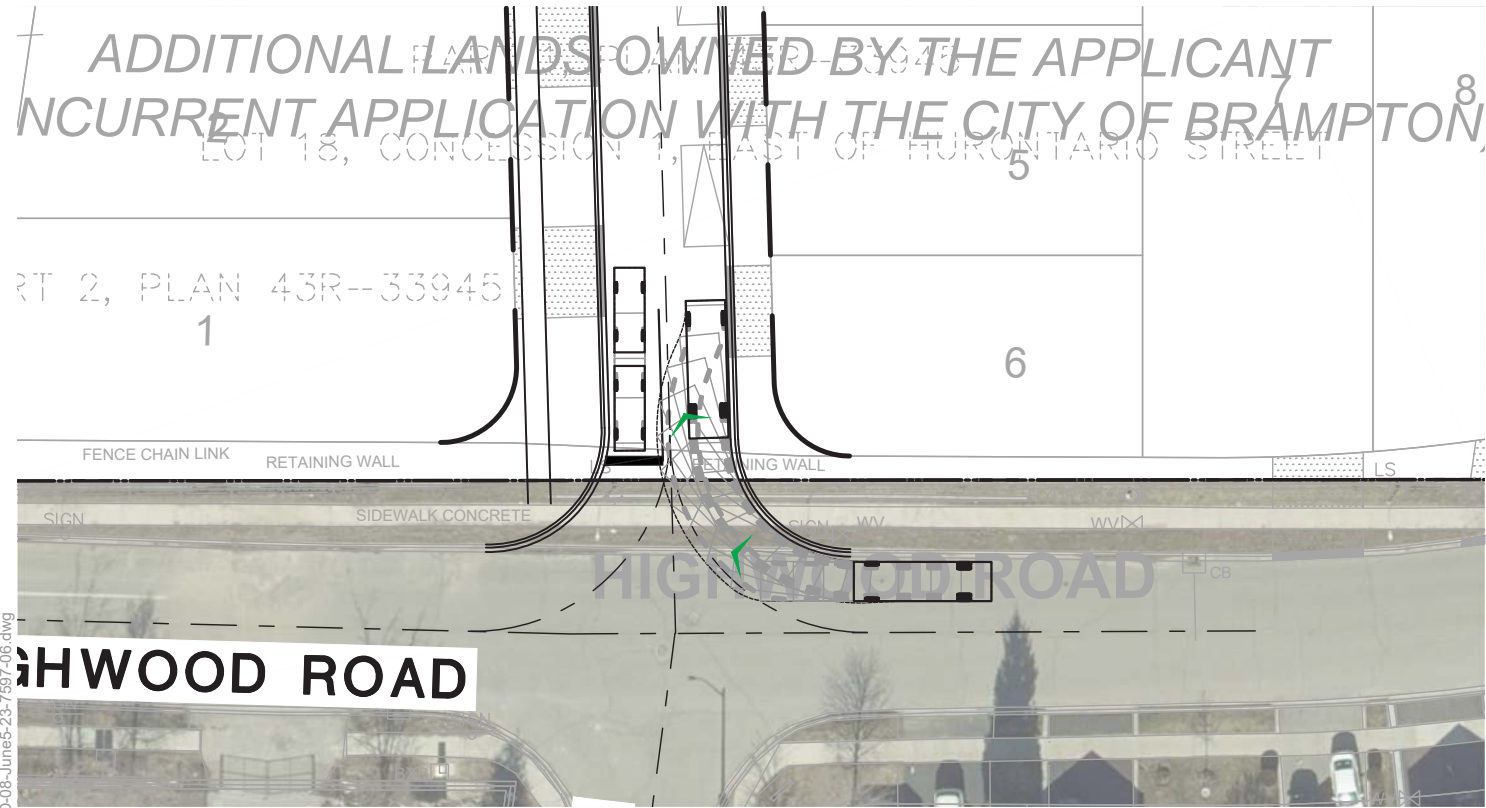

Date Plotted: June 6, 2023 File Name: J:\7597-06\BA\Functional Design\202308 - June5-23\BA-Ago Summer Valley-FD-08-June5-23-7597-06.dwg



SUMMER VALLEY
FUNCTIONAL DESIGN
VEHICLE MANOEUVRING DIAGRAMS
TAC P CAR AND TAC SINGLE UNIT (SU) TRUCK TWO-WAY MANOEUVRE

Project: SUMMER VALLEY
 Project No. 7597-06
 Date: MAY 9, 2023
 Revised: JUNE 6, 2023

Scale 1:500
 0 5 10 15 20m
 Drawing No. **VMD-03**

Appendix D
Pavement Marking and Signage Plan

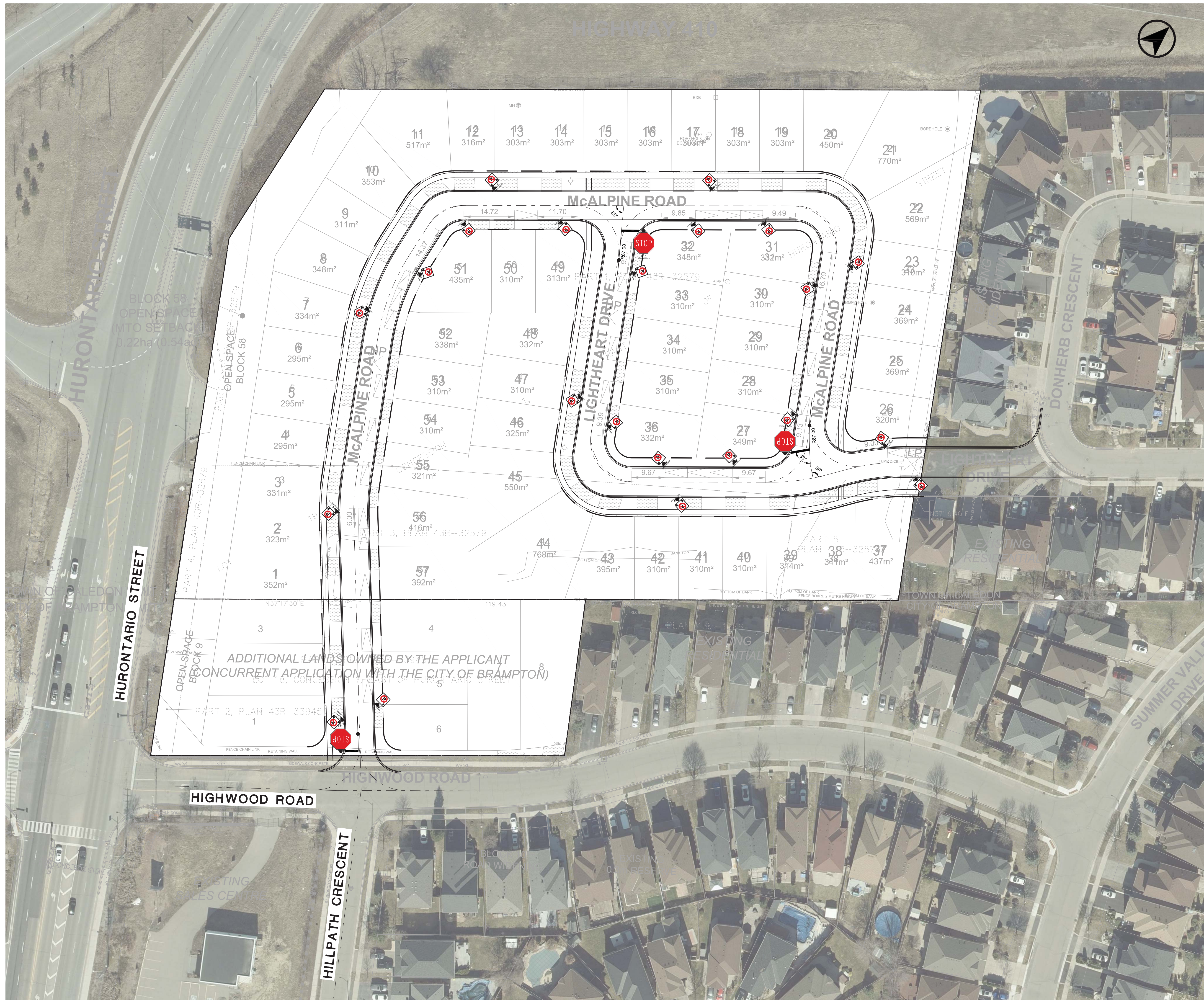

GENERAL NOTES

1. ALL SIGNS ARE SHOWN IN APPROXIMATE LOCATIONS AND TO BE DETERMINED ON SITE. SIGNS MUST BE VISIBLE TO DRIVER NOT OBSTRUCTED BY LANDSCAPE.
2. ALL SIGN POST LOCATIONS MUST BE PLACED SUCH THAT THE SIGN FACE OR EDGE OF SIGN WILL NOT PROJECT BEYOND THE CURB LINE.
3. TRAFFIC CONTROL SIGNS ARE TO BE MOUNTED SO THAT THE BOTTOM OF THE SIGNS ARE 2.1 METRES ABOVE CURB OR GRADE EXCEPT WHERE RESTRICTED BY OVERHEAD STRUCTURES/UTILITIES IN WHICH CASE THE DISTANCE BETWEEN BOTTOM OF SIGN AND FLOOR SHALL BE MAXIMIZED. SIGNS RUNNING PARALLEL AND PERPENDICULAR TO THE CURB FACE SHOULD BE PLACED SUCH THAT THE OUTER EDGE OF THE SIGN WILL NOT PROJECT BEYOND THE CURB INTO THE TRAFFIC LANE.
4. ALL SIGNS TO BE FITTED WITH A RUBBERIZED COPING AROUND EDGES WHEN OUTER EDGE OF SIGN EXTENDS BEYOND COLUMN EDGE AND / OR WHEN LESS THAN MINIMUM VERTICAL CLEARANCE (2.1 METRES) IS PROVIDED.

SIGNAGE LEGEND

ALL SIGNS MUST CONFORM TO THE ONTARIO TRAFFIC MANUAL (OTM) BOOK 5.

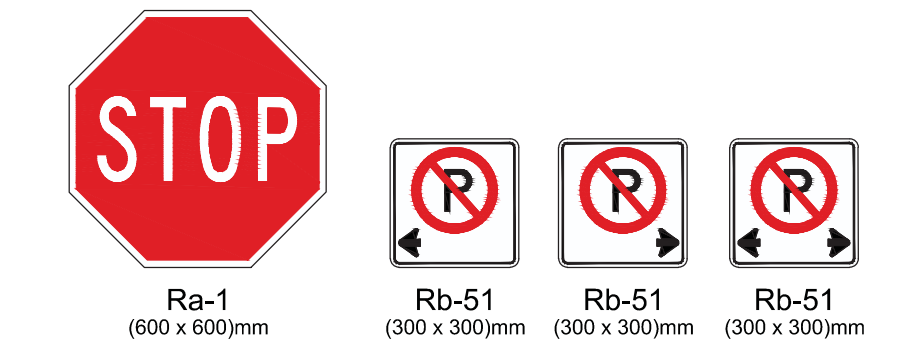

PAVEMENT MARKING LEGEND

ALL MARKINGS MUST CONFORM TO THE ONTARIO TRAFFIC MANUAL (OTM) BOOK 11.

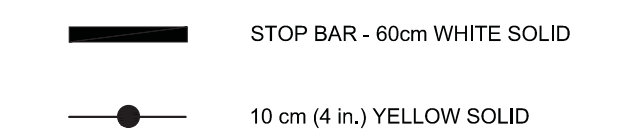

SIGN MOUNT LEGEND

ALL SIGNS ARE SHOWN IN APPROXIMATE LOCATIONS AND ARE TO BE DETERMINED ON SITE. SIGNS MUST BE VISIBLE TO DRIVER AND NOT OBSTRUCTED BY LANDSCAPE.



01	06-06-23	MA	ISSUED FOR DRAFT PLAN OF SUB-DIVISION
00	MM-DD-YR	INT	REVISION NOTE

BA Group
 BA Consulting Group Ltd.
 300 - 45 St. Clair Ave. W.
 Toronto ON M4V 1K3
 Tel: 416-961-7110
 www.bagroup.com

MOVEMENT IN URBAN ENVIRONMENTS
 BAGROUP.COM

ARGO SUMMER VALLEY

PAVEMENT MARKING & SIGNAGE PLAN

Date: June 6, 2023
 Project No.: 7597-06
 Scale: 1:500

SN-01

Appendix E
Terms of Reference and Correspondence

Ethan F. Sun

From: Ethan F. Sun
Sent: January 25, 2022 10:24 AM
To: 'Davidson, Adam'
Subject: RE: [EXTERNAL]Hurontario / Highwood Subdivision Development - Proposed Scope of Work for Transportation Study

Hi Adam,

Thanks for reviewing the ToR. We will include the queue analysis for the signalized intersection.

The proposed site access is directly across from Hillpath Crescent.

Thanks,

Ethan F. Sun
Lead Transportation Analyst

BA Consulting Group Ltd.
300 - 45 St. Clair Ave. W.
Toronto, ON M4V 1K9
TEL 416 961 7110 x228
EMAIL sun@bagroup.com



From: Davidson, Adam <Adam.Davidson@brampton.ca>
Sent: January 24, 2022 9:23 AM
To: Ethan F. Sun <sun@bagroup.com>
Subject: RE: [EXTERNAL]Hurontario / Highwood Subdivision Development - Proposed Scope of Work for Transportation Study

Morning Ethan,

Please include a queuing analysis for the signalized intersection (Hurontario at Highwood). Where is the proposed access(s)?

Thanks,

Adam Davidson

Transportation Planning Technologist | Public Works | City of Brampton
T: 437-217-6007 | F: 905-874-2599 | 1975 Williams Parkway | ON L6S 6E5

In order to prevent the spread of COVID-19, most of the City of Brampton facilities will remain closed. These closures will include my office at the Williams Parkway Operations Centre.

Nevertheless, I will continue to tend to business duties and be available remotely via adam.davidson@brampton.ca

Please reach out to me between the business hours of 8:30 AM until 4:30 PM on weekdays. I will be reachable via email, and I will be available to assist you.

From: Ethan F. Sun <sun@bagroup.com>
Sent: 2022/01/12 12:35 PM
To: Davidson, Adam <Adam.Davidson@brampton.ca>
Cc: Monaghan, David <David.Monaghan@brampton.ca>; Stuart B. Anderson <anderson@bagroup.com>
Subject: [EXTERNAL]Hurontario / Highwood Subdivision Development - Proposed Scope of Work for Transportation Study

Caution: This email originated from outside the organization. Do not click links or open attachments that you do not trust or are not expecting.

Hi Adam,

This is Ethan Sun from BA Group. I am reaching out to you because BA Group is retained as the Transportation Consultant for a development proposal near Hurontario St / Highwood Rd.

BA Group will be preparing the traffic and parking study associated with this development. The proposed Terms of Reference / Scope of Work associated with the Traffic and Parking Study is attached for your review.

Thanks and looking forward to hearing from you!

Ethan F. Sun
Lead Transportation Analyst

BA Consulting Group Ltd.

300 - 45 St. Clair Ave. W.
Toronto, ON M4V 1K9

TEL 416 961 7110 x228

EMAIL sun@bagroup.com



This message contains information which may be confidential and privileged. Unless you are the intended addressee (or authorized to receive for the intended addressee), you may not use, copy or disclose to anyone the message or any information contained in the message. If you have received the message in error, please advise the sender by reply and delete the message.

Please review the City of Brampton e-mail disclaimer statement at: <http://www.brampton.ca/EN/Online-Services/Pages/Privacy-Statement.aspx>

Memorandum

TO:

Jillian Britto, P.Eng.

Coordinator, Transportation Development
Town of Caledon
6311 Old Church Road, ON L7C 1J6
Jillian.Britto@caledon.ca

TO:

Adam Davidson

Transportation Planning Technologist, Public Works
City of Brampton
1975 Williams Parkway, ON, L6S 6E5
adam.davidson@brampton.ca

FROM:

Stuart B. Anderson
Ethan F. Sun

PROJECT:

7597-06
Hurontario / Highwood Subdivision

DATE:

December 20, 2021

SUBJECT: 12197 HURONTARIO ST, BRAMPTON AND CALEDON
DRAFT PLAN OF SUBDIVISION APPLICATION
TRAFFIC IMPACT AND PARKING STUDY PROPOSED SCOPE OF WORK

Dear Jillian and Adam,

The following is BA Group's proposed scope of work for a traffic impact study related to the Draft Plan of Subdivision application to permit the development of a residential subdivision near Hurontario Street / Highwood Road (12197 Hurontario Street) in the City of Brampton (the "City") and Town of Caledon (the "Town"). The development proposal consists of approximately 39 detached units and 46 townhouses.

The traffic impact study will be completed based on the following guidelines:

- City of Brampton's [Traffic Impact and Parking Study Terms of Reference](#) (April 2019)
- Town of Caledon's [Transportation Impact Studies Terms of Reference and Guidelines](#) (March 2017)
- Ministry of Transportation's [General Guidelines for the Preparation of Traffic Impact Studies](#) (February 2021)

1. Full Description

- The study will provide a full description of the proposed development, including:
 - Municipal address and existing land uses;
 - Proposed land uses, floor space, including a summary of each type of use, where applicable;
 - The Region of Peel's current [Controlled Access By-law](#) will be reviewed when designing the number of lanes, width and configuration of proposed access driveways, and distances between proposed access driveways and public road intersections. Design standards will be in accordance with those outlined in the TAC Manual on Geometric Design Guide for Canadian Roads and MTO Geometric Design Standards for Ontario Highways; and

- A combination of maps and other documentation will be used to identify all relevant information such as transit facilities/stops, bike paths, etc.

2. Traffic Volume Analysis

- Due to the low number of peak hour vehicle trips associated with a subdivision of approximately 70-85 residential units, we are proposing a localized study area and scope for study.
- The following intersections are included in the study area:
 - Hurontario Street / Highwood Road-Collingwood Avenue
 - Highwood Road / Hillpath Crescent
- Traffic signal timing will also be obtained from the City and the Town;
- Weekday AM and PM peak hours of traffic will be analyzed for a 5-year planning horizon.
- General background corridor traffic growth along Hurontario Street will be considered, as informed by traffic forecasts for the future road network included in the January 2018 Mayfield West Stage 2 Transportation Assessment.
- We will also contact the City and the Town to obtain details on surrounding developments in the area that would affect traffic capacity in the planning horizon year(s).

3. Trip Generation and Distribution

- Trip generation surveys from proxy developments that have similar operating characteristics as the proposed development, will be considered.
- The latest edition of the Institute of Transportation Engineers (ITE) trip generation rates will be utilized as a reference with the use of the greater of the average rate method or the fitted line equation.
- Trip distribution assumptions will be supported by one or more of the following:
 - Transportation Tomorrow Survey
 - Origin-destination surveys
 - Comprehensive travel surveys
 - Existing/anticipated travel patterns
 - Output from the Region of Peel Travel Demand Forecasting Model
 - Market studies.

4. Capacity Analysis

- Intersection capacity analysis will be completed using Synchro Version 11.0 and a combination of Highway Capacity Manual (HCM) 2000 methodology.
- For Synchro analysis, we will utilize the Region of Peel's [Regional Guidelines for Using Synchro 7.0](#).
- All intersections modelled as signalized intersections (other than existing signalized intersections) will be supported by an [Ontario Traffic Manual \(OTM\) Book 12](#) traffic control signals warrant.

5. Sight Distance Evaluation

- Sight distance availability for the proposed site access and for internal road intersections will be assessed.

7. Functional Design

- No access is proposed to Hurontario Street (the existing site accesses to Hurontario will be closed/removed), and a single site access is proposed to Highwood Road to form the north leg to the existing intersection of Highwood Road and Hillpath Crescent



- Functional design drawings detailing recommended road improvements at the intersection of Highwood Road / Hillpath Crescent/Site access will be provided.

9. Transportation Demand Management (TDM) Plan

- The report will also include a Transportation Demand Management (TDM) Plan.

8. Final Report

- The transportation report will document assumptions, methodology, analysis procedures, intersection performance results (for existing, future background and future total traffic conditions), findings and recommendations.
- The report will also include appropriate exhibits and tables as well as copies of all relevant supporting material.
- The report will also include an executive summary that contains key findings, conclusions and recommendations.
- The report will be stamped by a licensed professional engineer (P.Eng).

This scope of work should be confirmed with the Ministry of Transportation, City of Brampton and Town of Caledon's Transportation Planning Section to be appropriate before we proceed.

Please let me know if City staff require any modifications or additions.

Sincerely,

BA Consulting Group Ltd.

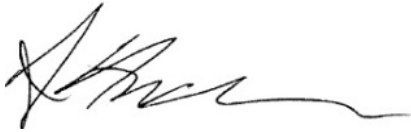

Stuart B. Anderson, P.Eng

Senior Associate

Appendix F
Turning Movement Counts



Turning Movement Count (2 . HIGHWOOD RD & HILLPATH CRES)

Start Time	E Approach HIGHWOOD RD					S Approach HILLPATH CRESCENT					W Approach HIGHWOOD RD					Int. Total (15 min)	Int. Total (1 hr)
	Thru E:W	Left E:S	UTurn E:E	Peds E:	Approach Total	Right S:E	Left S:W	UTurn S:S	Peds S:	Approach Total	Right W:S	Thru W:E	UTurn W:W	Peds W:	Approach Total		
07:30:00	11	0	0	0	11	0	3	0	1	3	1	6	0	0	7	21	
07:45:00	14	0	0	0	14	0	3	0	0	3	0	7	0	0	7	24	
08:00:00	10	0	0	0	10	0	2	0	0	2	2	9	0	0	11	23	
08:15:00	14	0	0	0	14	0	1	0	0	1	2	4	0	0	6	21	89
08:30:00	9	1	0	0	10	0	0	0	0	0	1	13	0	0	14	24	92
08:45:00	7	0	0	0	7	0	4	0	0	4	0	26	1	0	27	38	106
09:00:00	26	0	0	0	26	0	5	0	0	5	2	51	0	0	53	84	167
09:15:00	15	0	0	0	15	0	0	0	0	0	1	10	0	0	11	26	172
BREAK																	
16:00:00	6	0	0	0	6	0	0	0	1	0	4	7	0	0	11	17	
16:15:00	10	0	0	0	10	0	3	0	0	3	3	3	0	0	6	19	
16:30:00	7	0	0	0	7	0	1	0	0	1	5	17	0	0	22	30	
16:45:00	6	0	0	0	6	0	2	0	0	2	2	11	0	0	13	21	87
17:00:00	7	0	0	0	7	1	1	0	0	2	1	15	0	0	16	25	95
17:15:00	5	0	0	0	5	0	3	0	0	3	5	16	0	0	21	29	105
17:30:00	4	0	0	0	4	0	2	0	0	2	2	12	1	0	15	21	96
17:45:00	6	0	0	0	6	0	0	0	0	0	9	11	0	0	20	26	101
Grand Total	157	1	0	0	158	1	30	0	2	31	40	218	2	0	260	449	-
Approach%	99.4%	0.6%	0%	-	-	3.2%	96.8%	0%	-	-	15.4%	83.8%	0.8%	-	-	-	-
Totals %	35%	0.2%	0%	-	35.2%	0.2%	6.7%	0%	-	6.9%	8.9%	48.6%	0.4%	-	57.9%	-	-
Heavy	8	0	0	-	-	0	1	0	-	-	0	11	0	-	-	-	-
Heavy %	5.1%	0%	0%	-	-	0%	3.3%	0%	-	-	0%	5%	0%	-	-	-	-
Bicycles	-	-	-	-	-	-	-	-	-	-	-	-	-	-	-	-	-
Bicycle %	-	-	-	-	-	-	-	-	-	-	-	-	-	-	-	-	-



Peak Hour: 08:30 AM - 09:30 AM Weather: Scattered Clouds (-17.22 °C)

Start Time	E Approach HIGHWOOD RD					S Approach HILLPATH CRESCENT					W Approach HIGHWOOD RD					Int. Total (15 min)
	Thru	Left	UTurn	Peds	Approach Total	Right	Left	UTurn	Peds	Approach Total	Right	Thru	UTurn	Peds	Approach Total	
08:30:00	9	1	0	0	10	0	0	0	0	0	1	13	0	0	14	24
08:45:00	7	0	0	0	7	0	4	0	0	4	0	26	1	0	27	38
09:00:00	26	0	0	0	26	0	5	0	0	5	2	51	0	0	53	84
09:15:00	15	0	0	0	15	0	0	0	0	0	1	10	0	0	11	26
Grand Total	57	1	0	0	58	0	9	0	0	9	4	100	1	0	105	172
Approach%	98.3%	1.7%	0%	-	-	0%	100%	0%	-	-	3.8%	95.2%	1%	-	-	-
Totals %	33.1%	0.6%	0%	-	33.7%	0%	5.2%	0%	-	5.2%	2.3%	58.1%	0.6%	-	61%	-
PHF	0.55	0.25	0	-	0.56	0	0.45	0	-	0.45	0.5	0.49	0.25	-	0.5	-
Heavy	2	0	0	-	2	0	0	0	-	0	0	6	0	-	6	-
Heavy %	3.5%	0%	0%	-	3.4%	0%	0%	0%	-	0%	0%	6%	0%	-	5.7%	-
Lights	55	1	0	-	56	0	9	0	-	9	4	94	1	-	99	-
Lights %	96.5%	100%	0%	-	96.6%	0%	100%	0%	-	100%	100%	94%	100%	-	94.3%	-
Single-Unit Trucks	0	0	0	-	0	0	0	0	-	0	0	2	0	-	2	-
Single-Unit Trucks %	0%	0%	0%	-	0%	0%	0%	0%	-	0%	0%	2%	0%	-	1.9%	-
Buses	2	0	0	-	2	0	0	0	-	0	0	4	0	-	4	-
Buses %	3.5%	0%	0%	-	3.4%	0%	0%	0%	-	0%	0%	4%	0%	-	3.8%	-
Pedestrians	-	-	-	0	-	-	-	-	0	-	-	-	-	0	-	-
Pedestrians%	-	-	-	0%	-	-	-	-	0%	-	-	-	-	0%	-	-

Peak Hour: 04:30 PM - 05:30 PM Weather: Overcast Clouds (-12 °C)

Start Time	E Approach HIGHWOOD RD					S Approach HILLPATH CRESCENT					W Approach HIGHWOOD RD					Int. Total (15 min)
	Thru	Left	UTurn	Peds	Approach Total	Right	Left	UTurn	Peds	Approach Total	Right	Thru	UTurn	Peds	Approach Total	
16:30:00	7	0	0	0	7	0	1	0	0	1	5	17	0	0	22	30
16:45:00	6	0	0	0	6	0	2	0	0	2	2	11	0	0	13	21
17:00:00	7	0	0	0	7	1	1	0	0	2	1	15	0	0	16	25
17:15:00	5	0	0	0	5	0	3	0	0	3	5	16	0	0	21	29
Grand Total	25	0	0	0	25	1	7	0	0	8	13	59	0	0	72	105
Approach%	100%	0%	0%		-	12.5%	87.5%	0%		-	18.1%	81.9%	0%		-	-
Totals %	23.8%	0%	0%		23.8%	1%	6.7%	0%		7.6%	12.4%	56.2%	0%		68.6%	-
PHF	0.89	0	0		0.89	0.25	0.58	0		0.67	0.65	0.87	0		0.82	-
Heavy	1	0	0		1	0	1	0		1	0	0	0		0	-
Heavy %	4%	0%	0%		4%	0%	14.3%	0%		12.5%	0%	0%	0%		0%	-
Lights	24	0	0		24	1	6	0		7	13	59	0		72	-
Lights %	96%	0%	0%		96%	100%	85.7%	0%		87.5%	100%	100%	0%		100%	-
Single-Unit Trucks	1	0	0		1	0	1	0		1	0	0	0		0	-
Single-Unit Trucks %	4%	0%	0%		4%	0%	14.3%	0%		12.5%	0%	0%	0%		0%	-
Buses	0	0	0		0	0	0	0		0	0	0	0		0	-
Buses %	0%	0%	0%		0%	0%	0%	0%		0%	0%	0%	0%		0%	-
Pedestrians	-	-	-	0	-	-	-	0		-	-	-	0		-	-
Pedestrians%	-	-	-	0%	-	-	-	0%		-	-	-	0%		-	-

Peak Hour: 08:30 AM - 09:30 AM Weather: Scattered Clouds (-17.22 °C)

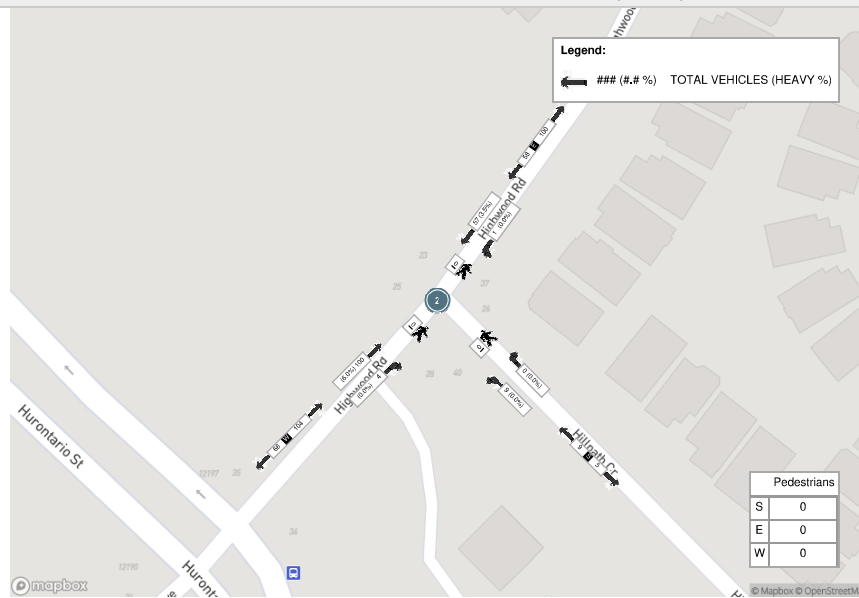

Peak Hour: 04:30 PM - 05:30 PM Weather: Overcast Clouds (-12 °C)

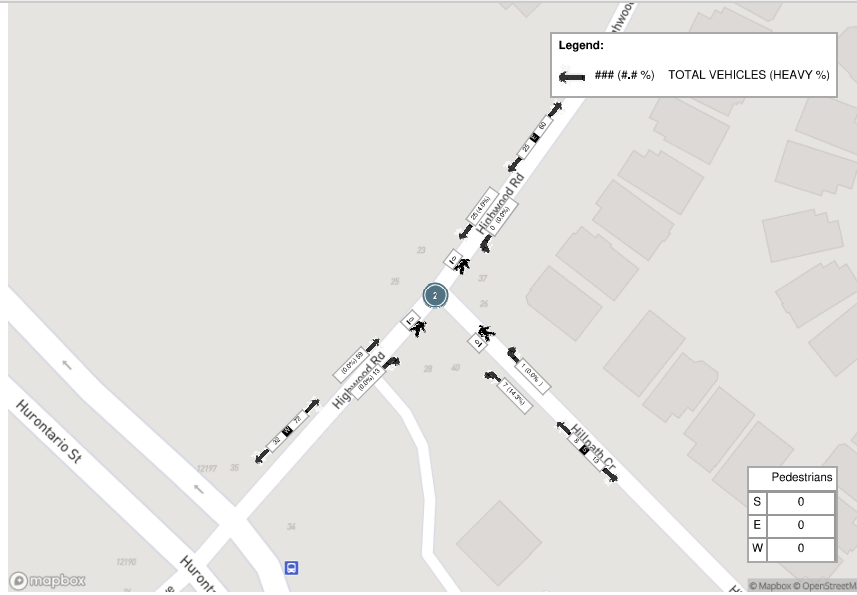

Turning Movement Count (1. HURONTARIO ST & HIGHWOOD RD)

Start Time	N Approach HURONTARIO ST						E Approach HIGHWOOD RD						S Approach HURONTARIO ST						W Approach COLLINSWOOD AVE						Int. Total (15 min)	Int. Total (1 hr)
	Right N/W	Thru N/S	Left N/E	UTurn N/N	Peds N	Approach Total	Right E/N	Thru E/W	Left E/S	UTurn E/E	Peds E	Approach Total	Right S/E	Thru S/N	Left S/W	UTurn S/S	Peds S	Approach Total	Right W/S	Thru W/E	Left W/N	UTurn W/W	Peds W	Approach Total		
07:30:00	6	212	2	0	0	220	8	1	5	0	0	14	0	150	2	0	0	152	12	6	25	0	0	43	429	
07:45:00	7	229	5	0	0	241	9	0	8	0	0	17	2	122	3	0	1	127	12	1	19	0	0	32	417	
08:00:00	11	225	5	0	0	241	8	0	3	0	0	11	3	106	2	0	0	111	9	2	14	0	0	25	388	
08:15:00	4	194	4	0	0	202	10	0	4	0	0	14	0	140	5	0	0	145	5	2	11	0	1	18	379	1613
08:30:00	13	231	11	5	0	260	8	1	2	0	0	11	3	171	4	0	0	178	11	0	19	0	0	30	479	1663
08:45:00	6	243	17	5	1	271	7	0	5	0	0	12	5	175	2	0	1	182	6	5	14	0	1	25	490	1736
09:00:00	2	160	25	0	1	187	22	4	5	0	1	31	9	128	7	0	0	144	8	19	4	0	0	31	393	1741
09:15:00	3	154	8	0	0	165	9	1	4	0	0	14	3	137	4	0	0	144	5	0	6	0	0	11	334	1696
BREAK																										
16:00:00	24	257	5	0	0	286	4	2	0	0	0	6	5	209	16	0	0	230	6	1	10	0	0	17	539	
16:15:00	19	221	3	0	0	243	9	1	3	0	0	13	3	213	12	0	1	228	7	0	9	0	1	16	500	
16:30:00	23	227	11	1	0	262	5	0	0	0	0	5	8	201	7	1	0	217	6	3	11	0	0	20	504	
16:45:00	19	239	10	0	0	268	3	2	6	0	0	11	3	176	11	0	0	190	7	0	7	0	0	14	493	2026
17:00:00	24	231	11	0	1	266	6	1	1	0	1	8	7	210	5	0	0	222	6	0	5	0	0	11	507	1994
17:15:00	29	233	9	0	0	271	2	1	6	0	1	9	10	189	11	0	1	210	6	0	11	0	1	17	507	2001
17:30:00	23	261	7	0	0	291	5	0	2	0	1	7	6	175	20	0	0	201	10	2	10	0	0	22	521	2018
17:45:00	23	206	11	0	0	240	4	1	1	0	0	6	8	160	12	0	0	180	7	1	7	0	0	15	441	1876
Grand Total	236	3523	144	11	3	3914	119	15	65	0	4	189	75	2662	123	1	4	2861	123	42	182	0	4	347	7311	-
Approach%	6%	90%	3.7%	0.3%	-	-	6%	7.9%	23.1%	0%	-	-	2.6%	93%	4.3%	0%	-	-	35.4%	12.1%	52.4%	0%	-	-	-	-
Totals %	3.2%	48.2%	2%	0.2%	-	53.5%	1.6%	0.2%	0.8%	0%	-	2.6%	1%	36.4%	1.7%	0%	-	39.1%	1.7%	0.6%	2.5%	0%	-	4.7%	-	-
Heavy %	3	164	3	0	-	-	4	2	3	0	-	-	4	150	3	0	-	-	7	4	7	0	-	-	-	-
Heavy %	1.3%	4.7%	2.1%	0%	-	-	3.4%	13.3%	5.5%	0%	-	-	5.3%	5.6%	2.4%	0%	-	-	5.7%	9.5%	3.8%	0%	-	-	-	-
Bicycles %	-	-	-	-	-	-	-	-	-	-	-	-	-	-	-	-	-	-	-	-	-	-	-	-	-	-
Bicycles %	-	-	-	-	-	-	-	-	-	-	-	-	-	-	-	-	-	-	-	-	-	-	-	-	-	-



Peak Hour: 08:15 AM - 09:15 AM Weather: Scattered Clouds (-17.22 °C)

Start Time	N Approach HURONTARIO ST						E Approach HIGHWOOD RD						S Approach HURONTARIO ST						W Approach COLLINGWOOD AVE						Hi. Total (15 min)
	Right	Thru	Left	UTurn	Peds	Approach Total	Right	Thru	Left	UTurn	Peds	Approach Total	Right	Thru	Left	UTurn	Peds	Approach Total	Right	Thru	Left	UTurn	Peds	Approach Total	
08:15:00	4	194	4	0	0	202	10	0	4	0	0	14	0	140	5	0	0	145	5	2	11	0	1	18	379
08:30:00	13	231	11	5	0	260	8	1	2	0	0	11	3	171	4	0	0	178	11	0	19	0	0	30	479
08:45:00	6	243	17	5	1	271	7	0	5	0	0	12	5	175	2	0	1	182	6	5	14	0	1	25	490
09:00:00	2	160	25	0	1	187	22	4	5	0	1	31	9	128	7	0	0	144	8	19	4	0	0	31	393
Grand Total	25	628	57	10	2	920	47	5	16	0	1	68	17	614	18	0	1	649	30	26	48	0	2	104	1741
Approach%	2.7%	90%	6.2%	1.1%	-	-	69.1%	7.4%	23.5%	0%	-	2.6%	94.6%	2.8%	0%	-	28.8%	25%	46.2%	0%	-	-	-	-	-
Totals %	1.4%	47.6%	3.3%	0.6%	0.2%	52.8%	2.7%	0.3%	0.9%	0%	3.9%	1%	35.3%	1%	0%	37.3%	1.7%	1.5%	2.8%	0%	6%	-	-	-	-
PHF	0.48	0.85	0.57	0.5	0.35	0.53	0.53	0.31	0.8	0	0.55	0.47	0.88	0.64	0	0.89	0.68	0.34	0.63	0	0.84	-	-	-	-
Heavy	0	69	1	0	0	70	2	0	1	0	3	1	50	1	0	52	2	2	4	0	8	-	-	-	-
Heavy %	0%	8.2%	1.8%	0%	0%	7.6%	4.3%	0%	6.3%	0%	4.4%	5.9%	8.1%	5.6%	0%	8%	6.7%	7.7%	8.3%	0%	7.7%	-	-	-	-
Lights	25	759	56	10	2	850	45	5	15	0	65	16	564	17	0	320	28	24	44	0	36	-	-	-	-
Lights %	100%	91.7%	98.2%	100%	100%	92.4%	95.7%	100%	93.8%	0%	95.6%	94.1%	91.9%	94.4%	0%	92%	93.3%	92.3%	91.7%	0%	92.3%	-	-	-	-
Single-Unit Trucks	0	54	0	0	0	54	0	0	0	0	0	0	31	0	0	31	0	0	0	0	0	-	-	-	-
Single-Unit Trucks %	0%	6.5%	0%	0%	0%	5.9%	0%	0%	0%	0%	0%	0%	5%	0%	0%	4.8%	0%	0%	0%	0%	0%	-	-	-	-
Buses	0	8	1	0	0	9	2	0	1	0	3	1	10	1	0	12	2	2	4	0	8	-	-	-	-
Buses %	0%	1%	1.8%	0%	0%	1%	4.3%	0%	6.3%	0%	4.4%	5.9%	1.6%	5.6%	0%	1.8%	6.7%	7.7%	8.3%	0%	7.7%	-	-	-	-
Articulated Trucks	0	7	0	0	0	7	0	0	0	0	0	0	9	0	0	9	0	0	0	0	0	-	-	-	-
Articulated Trucks %	0%	0.8%	0%	0%	0%	0.8%	0%	0%	0%	0%	0%	0%	1.5%	0%	0%	1.4%	0%	0%	0%	0%	0%	-	-	-	-
Pedestrians	-	-	-	-	2	-	-	-	-	-	1	-	-	-	-	1	-	-	-	-	2	-	-	-	-
Pedestrians %	-	-	-	-	33.3%	-	-	-	-	-	16.7%	-	-	-	-	16.7%	-	-	-	-	33.3%	-	-	-	-



Peak Hour: 04:00 PM - 05:00 PM Weather: Overcast Clouds (-12 °C)

Start Time	N Approach HURONTARIO ST						E Approach HIGHWOOD RD						S Approach HURONTARIO ST						W Approach COLLINGWOOD AVE						Hi. Total (15 min)
	Right	Thru	Left	UTurn	Peds	Approach Total	Right	Thru	Left	UTurn	Peds	Approach Total	Right	Thru	Left	UTurn	Peds	Approach Total	Right	Thru	Left	UTurn	Peds	Approach Total	
16:00:00	24	257	5	0	0	286	4	2	0	0	0	6	5	209	16	0	0	230	6	1	10	0	0	17	539
16:15:00	19	221	3	0	0	243	9	1	3	0	0	13	3	213	12	0	1	228	7	0	9	0	1	18	500
16:30:00	23	227	11	1	0	262	5	0	0	0	0	5	8	201	7	1	0	217	6	3	11	0	0	20	504
16:45:00	19	229	10	0	0	268	3	2	6	0	0	11	3	176	11	0	0	190	7	0	7	0	0	14	483
Grand Total	85	944	29	1	0	1059	21	5	9	0	0	35	19	799	46	1	1	865	26	4	37	0	1	67	2026
Approach%	8%	89.1%	2.7%	0.1%	-	-	69%	14.3%	25.7%	0%	-	2.2%	92.4%	5.3%	0.1%	-	38.8%	6%	55.2%	0%	-	-	-	-	
Totals %	4.2%	46.6%	1.4%	0%	0%	52.3%	1%	0.2%	0.4%	0%	1.7%	0.9%	39.4%	2.3%	0%	42.7%	1.3%	0.2%	1.8%	0%	3.3%	-	-	-	-
PHF	0.89	0.92	0.66	0.25	0.33	0.93	0.58	0.63	0.38	0	0.67	0.59	0.94	0.72	0.25	0.94	0.93	0.33	0.84	0	0.84	-	-	-	-
Heavy	0	37	1	0	0	38	2	2	0	0	0	4	0	23	1	0	24	1	0	1	0	2	-	-	-
Heavy %	0%	3.9%	3.4%	0%	0%	3.6%	9.5%	40%	0%	0%	11.4%	0%	2.9%	2.2%	0%	2.8%	3.8%	0%	2.7%	0%	3%	-	-	-	-
Lights	85	937	29	1	0	1021	19	3	9	0	0	31	19	776	45	1	1	841	25	4	36	0	0	65	-
Lights %	100%	96.1%	96.8%	100%	100%	96.4%	90.5%	60%	100%	0%	88.6%	100%	97.1%	97.8%	100%	97.2%	96.2%	100%	97.2%	0%	97%	-	-	-	-
Single-Unit Trucks	0	12	0	0	0	12	1	0	0	0	1	0	11	0	0	11	0	0	0	0	0	-	-	-	-
Single-Unit Trucks %	0%	1.3%	0%	0%	0%	1.1%	4.8%	0%	0%	0%	2.9%	0%	1.4%	0%	0%	1.3%	0%	0%	0%	0%	0%	-	-	-	-
Buses	0	11	1	0	0	12	1	2	0	0	3	0	8	1	0	7	1	0	1	0	2	-	-	-	-
Buses %	0%	1.2%	3.4%	0%	0%	1.1%	4.8%	40%	0%	0%	8.6%	0%	0.8%	2.2%	0%	0.8%	3.8%	0%	2.7%	0%	3%	-	-	-	-
Articulated Trucks	0	14	0	0	0	14	0	0	0	0	0	0	8	0	0	8	0	0	0	0	0	-	-	-	-
Articulated Trucks %	0%	1.5%	0%	0%	0%	1.3%	0%	0%	0%	0%	0%	0%	0.8%	0%	0%	0.7%	0%	0%	0%	0%	0%	-	-	-	-
Pedestrians	-	-	-	-	0	-	-	-	-	-	0	-	-	-	-	1	-	-	-	-	1	-	-	-	-
Pedestrians %	-	-	-	-	0%	-	-	-	-	-	0%	-	-	-	-	50%	-	-	-	-	50%	-	-	-	-

Peak Hour: 08:15 AM - 09:15 AM Weather: Scattered Clouds (-17.22 °C)

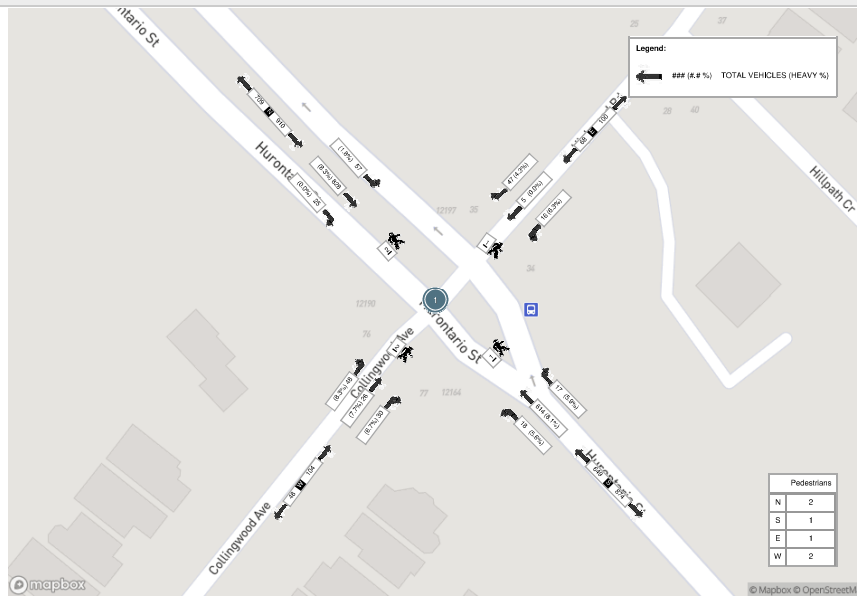

Peak Hour: 04:00 PM - 05:00 PM Weather: Overcast Clouds (-12 °C)

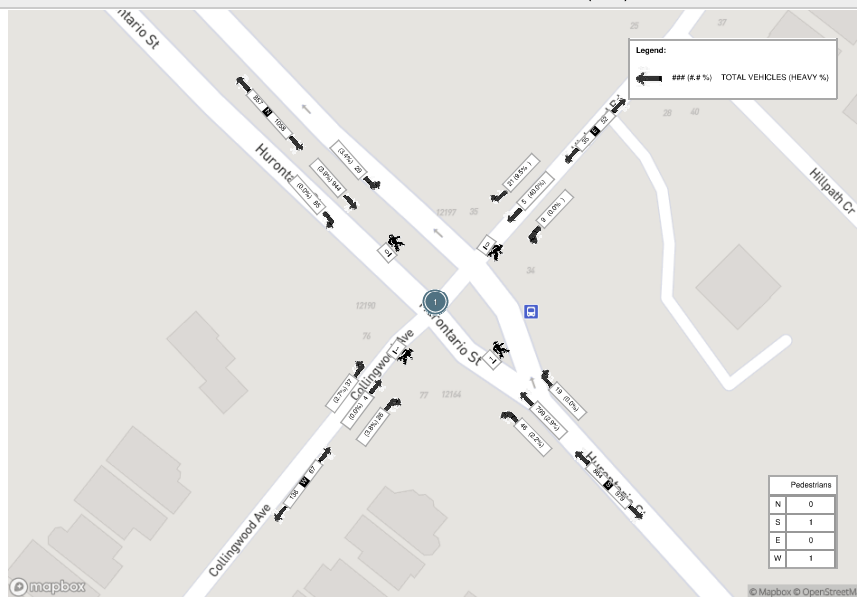

Appendix G
Pages from ITE Trip Generation Manual

Land Use: 210

Single-Family Detached Housing

Description

A single-family detached housing site includes any single-family detached home on an individual lot. A typical site surveyed is a suburban subdivision.

Specialized Land Use

Data have been submitted for several single-family detached housing developments with homes that are commonly referred to as patio homes. A patio home is a detached housing unit that is located on a small lot with little (or no) front or back yard. In some subdivisions, communal maintenance of outside grounds is provided for the patio homes. The three patio home sites total 299 dwelling units with overall weighted average trip generation rates of 5.35 vehicle trips per dwelling unit for weekday, 0.26 for the AM adjacent street peak hour, and 0.47 for the PM adjacent street peak hour. These patio home rates based on a small sample of sites are lower than those for single-family detached housing (Land Use 210), lower than those for single-family attached housing (Land Use 251), and higher than those for senior adult housing -- single-family (Land Use 251). Further analysis of this housing type will be conducted in a future edition of *Trip Generation Manual*.

Additional Data

The technical appendices provide supporting information on time-of-day distributions for this land use. The appendices can be accessed through either the ITETripGen web app or the trip generation resource page on the ITE website (<https://www.ite.org/technical-resources/topics/trip-and-parking-generation/>).

For 30 of the study sites, data on the number of residents and number of household vehicles are available. The overall averages for the 30 sites are 3.6 residents per dwelling unit and 1.5 vehicles per dwelling unit.

The sites were surveyed in the 1980s, the 1990s, the 2000s, and the 2010s in Arizona, California, Connecticut, Delaware, Illinois, Indiana, Kentucky, Maryland, Massachusetts, Minnesota, Montana, New Jersey, North Carolina, Ohio, Ontario (CAN), Oregon, Pennsylvania, South Carolina, South Dakota, Tennessee, Vermont, Virginia, and West Virginia.

Source Numbers

100, 105, 114, 126, 157, 167, 177, 197, 207, 211, 217, 267, 275, 293, 300, 319, 320, 356, 357, 367, 384, 387, 407, 435, 522, 550, 552, 579, 598, 601, 603, 614, 637, 711, 716, 720, 728, 735, 868, 869, 903, 925, 936, 1005, 1007, 1008, 1010, 1033, 1066, 1077, 1078, 1079

Single-Family Detached Housing (210)

Vehicle Trip Ends vs: Dwelling Units

On a: Weekday,

Peak Hour of Adjacent Street Traffic,

One Hour Between 7 and 9 a.m.

Setting/Location: General Urban/Suburban

Number of Studies: 192

Avg. Num. of Dwelling Units: 226

Directional Distribution: 26% entering, 74% exiting

Vehicle Trip Generation per Dwelling Unit

Average Rate	Range of Rates	Standard Deviation
0.70	0.27 - 2.27	0.24

Data Plot and Equation

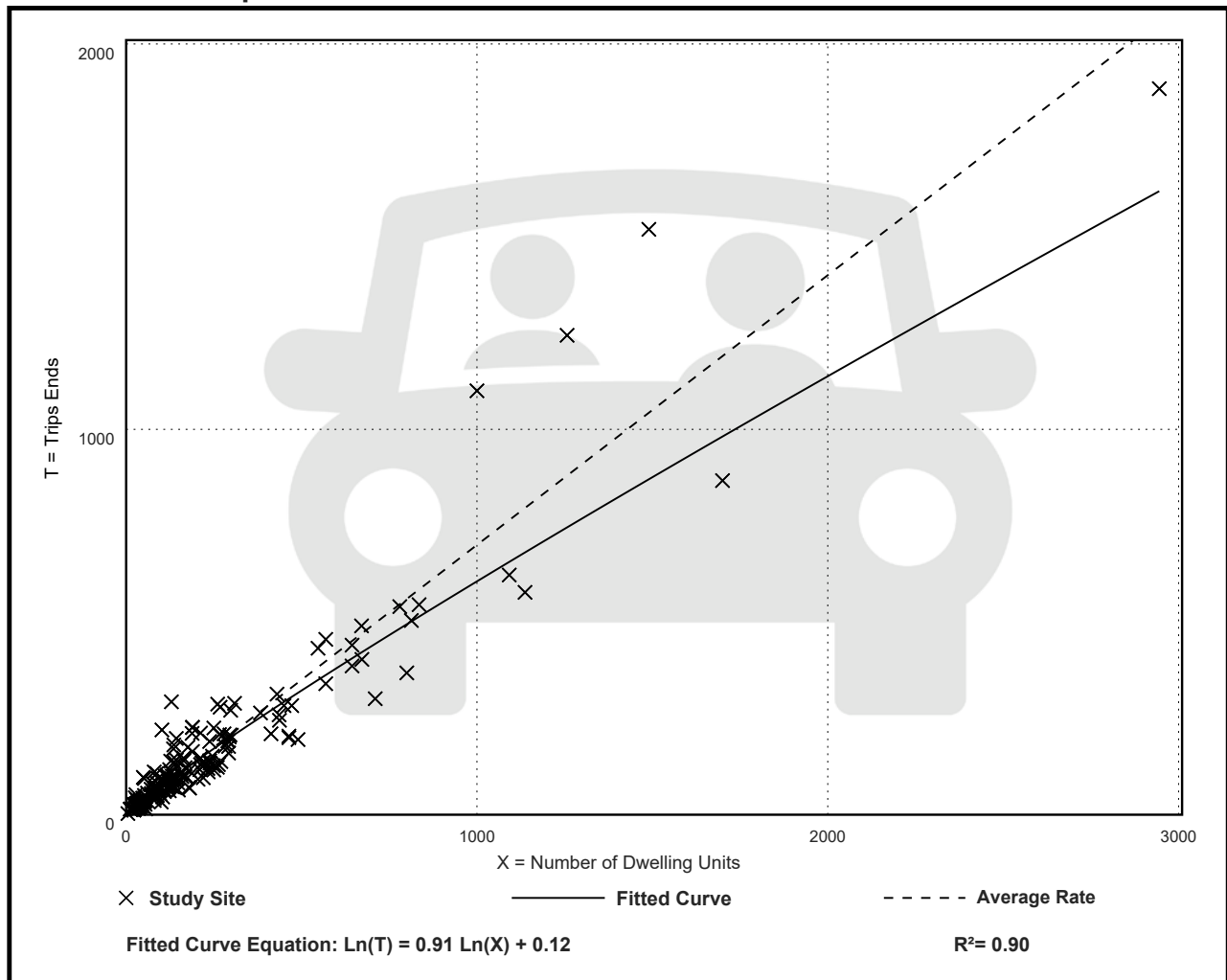

Single-Family Detached Housing (210)

Vehicle Trip Ends vs: Dwelling Units

On a: Weekday,

Peak Hour of Adjacent Street Traffic,

One Hour Between 4 and 6 p.m.

Setting/Location: General Urban/Suburban

Number of Studies: 208

Avg. Num. of Dwelling Units: 248

Directional Distribution: 63% entering, 37% exiting

Vehicle Trip Generation per Dwelling Unit

Average Rate	Range of Rates	Standard Deviation
0.94	0.35 - 2.98	0.31

Data Plot and Equation

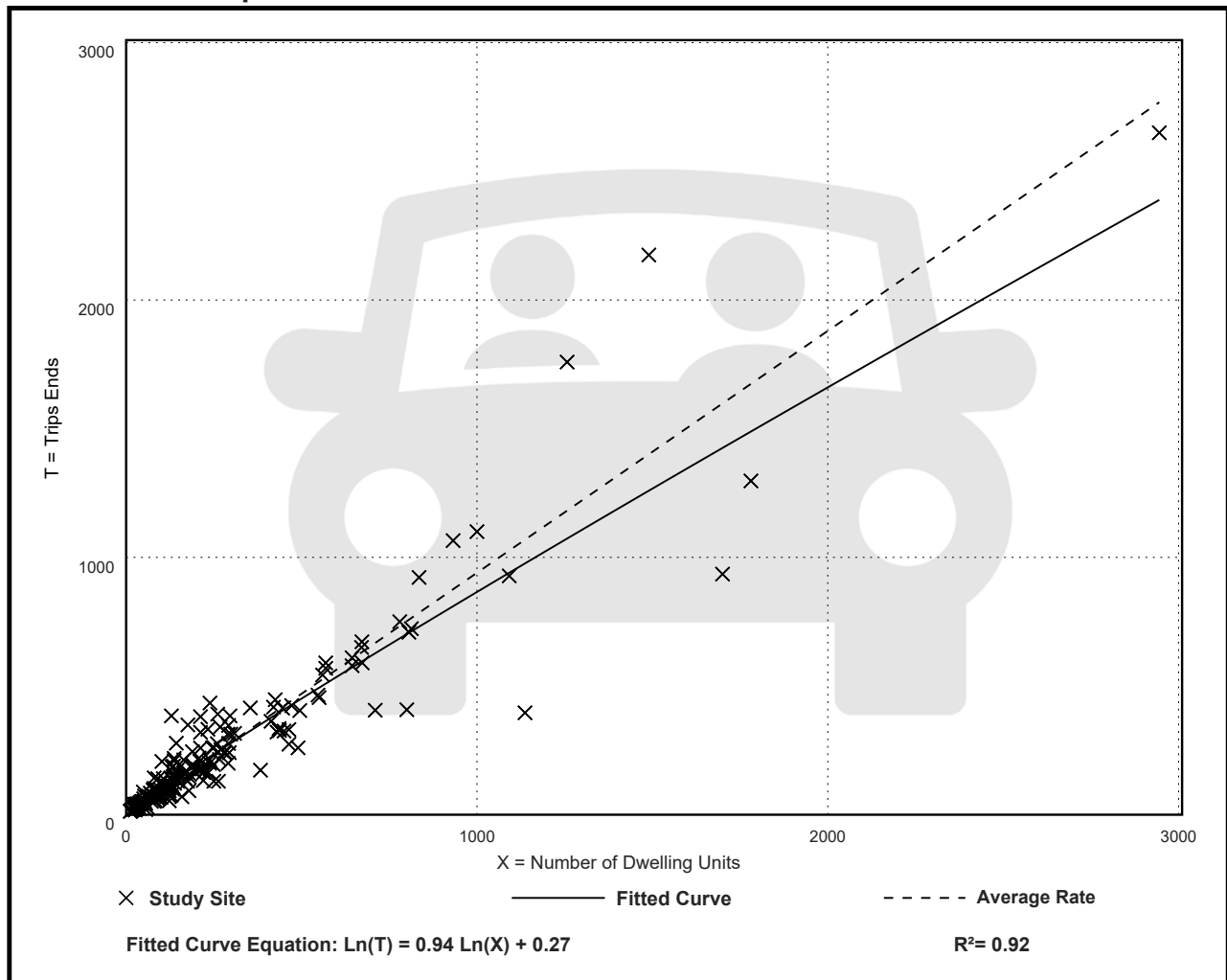

Land Use: 215

Single-Family Attached Housing

Description

Single-family attached housing includes any single-family housing unit that shares a wall with an adjoining dwelling unit, whether the walls are for living space, a vehicle garage, or storage space.

Additional Data

The database for this land use includes duplexes (defined as a single structure with two distinct dwelling units, typically joined side-by-side and each with at least one outside entrance) and townhouses/rowhouses (defined as a single structure with three or more distinct dwelling units, joined side-by-side in a row and each with an outside entrance).

The technical appendices provide supporting information on time-of-day distributions for this land use. The appendices can be accessed through either the ITETripGen web app or the trip generation resource page on the ITE website (<https://www.ite.org/technical-resources/topics/trip-and-parking-generation/>).

The sites were surveyed in the 1980s, the 1990s, the 2000s, and the 2010s in British Columbia (CAN), California, Georgia, Illinois, Maryland, Massachusetts, Minnesota, New Jersey, Ontario (CAN), Oregon, Pennsylvania, South Dakota, Utah, Virginia, and Wisconsin.

Source Numbers

168, 204, 211, 237, 305, 306, 319, 321, 357, 390, 418, 525, 571, 583, 638, 735, 868, 869, 870, 896, 912, 959, 1009, 1046, 1056, 1058, 1077

Single-Family Attached Housing (215)

Vehicle Trip Ends vs: Dwelling Units

On a: **Weekday,**

Peak Hour of Adjacent Street Traffic,

One Hour Between 7 and 9 a.m.

Setting/Location: General Urban/Suburban

Number of Studies: 46

Avg. Num. of Dwelling Units: 135

Directional Distribution: 31% entering, 69% exiting

Vehicle Trip Generation per Dwelling Unit

Average Rate	Range of Rates	Standard Deviation
0.48	0.12 - 0.74	0.14

Data Plot and Equation

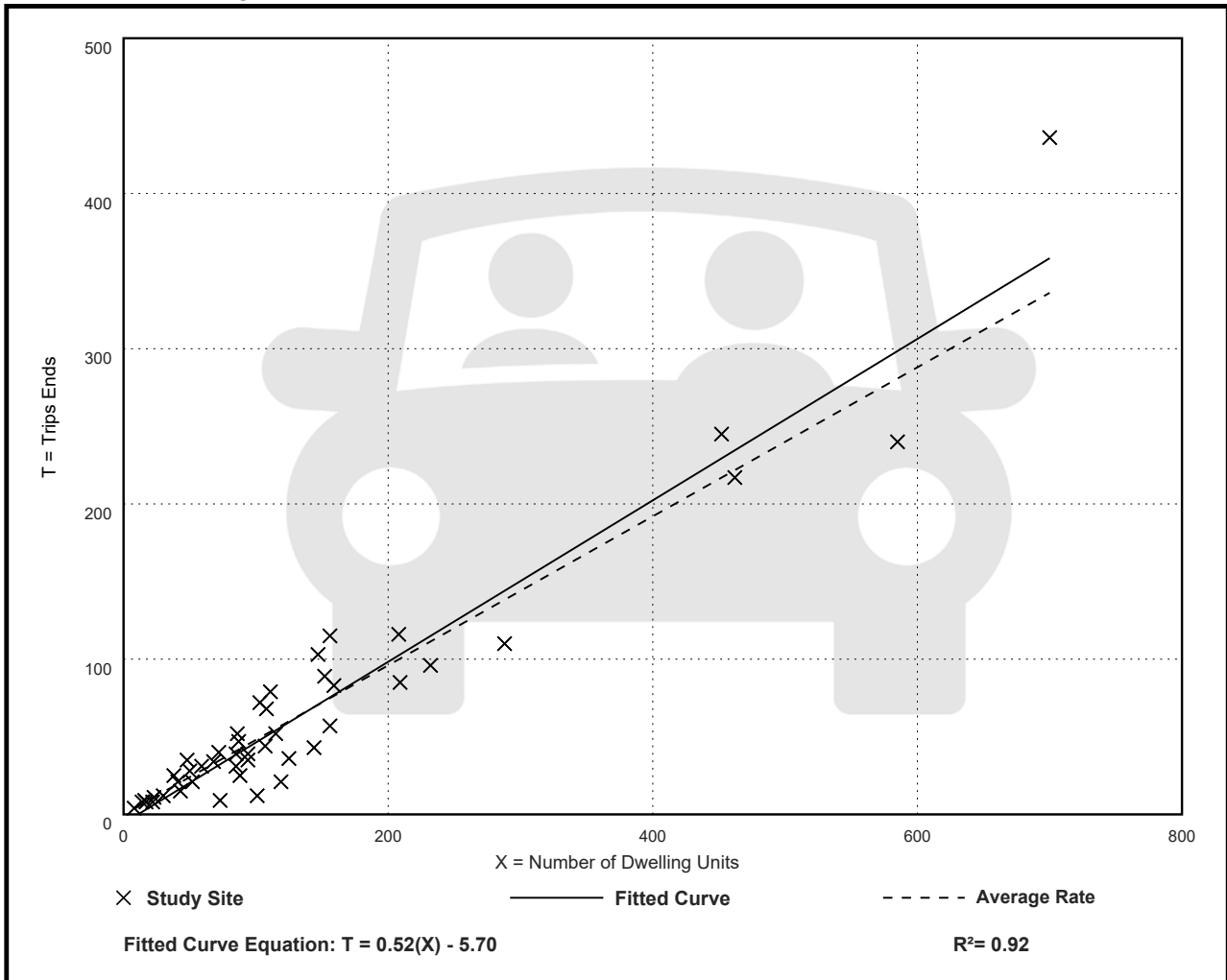

Single-Family Attached Housing (215)

Vehicle Trip Ends vs: Dwelling Units

On a: Weekday,

Peak Hour of Adjacent Street Traffic,

One Hour Between 4 and 6 p.m.

Setting/Location: General Urban/Suburban

Number of Studies: 51

Avg. Num. of Dwelling Units: 136

Directional Distribution: 57% entering, 43% exiting

Vehicle Trip Generation per Dwelling Unit

Average Rate	Range of Rates	Standard Deviation
0.57	0.17 - 1.25	0.18

Data Plot and Equation

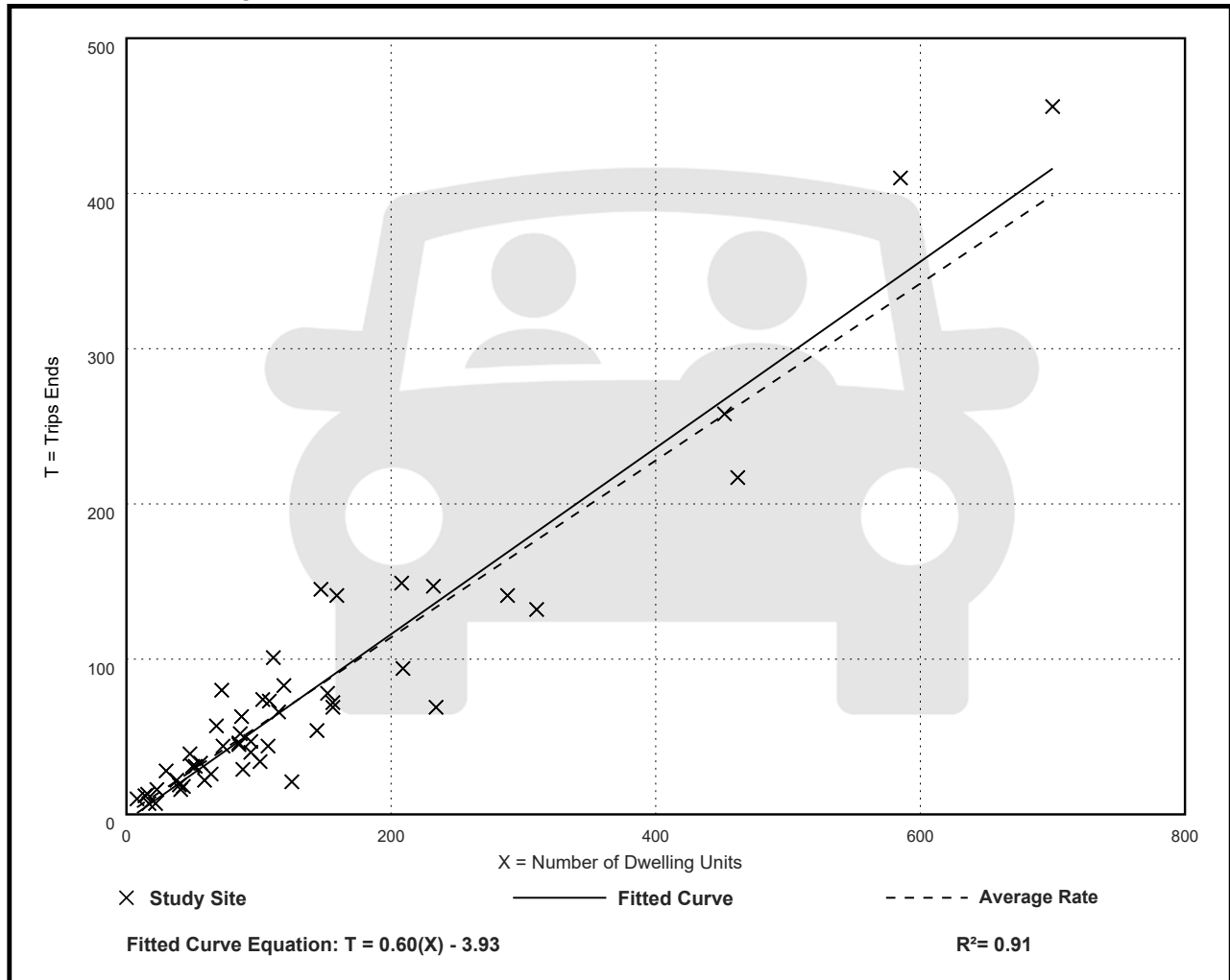

Appendix H
Transportation Tomorrow Survey (TTS) Data

12197, 12211, 12213 and 12231 Hurontario Street

7597-06

Residential Vehicular Site Traffic Distribution (AM Peak Hour)

Outbound

BA Group - EFS

2022-05-18

Fri Feb 04 2022 13:29:05 GMT-0500 (Eastern Standard Time) - Run Time: 3367ms

Cross Tabulation Query Form - Trip - 2016 v1.1

Row: Planning district of destination - pd_dest
Column: 2006 GTA zone of origin - gta06_orig

Filters:

2006 GTA zone of origin - gta06_orig In 3007,3381,3459
and
Start time of trip - start_time In 600-859
and
Trip purpose of origin - purp_orig In H
and
Primary travel mode of trip - mode_prime In D,M,P,T,U

Trip 2016

Table:

	3007	3381	3459	Total
PD 1 of Toronto	20	0	33	53
PD 2 of Toronto	0	0	23	23
PD 3 of Toronto	0	0	40	40
PD 7 of Toronto	0	0	41	41
PD 8 of Toronto	0	0	85	85
PD 9 of Toronto	14	0	25	39
PD 10 of Toronto	17	0	16	33
PD 11 of Toronto	0	11	0	11
PD 16 of Toronto	0	0	15	15
Newmarket	0	0	8	8
Richmond Hill	0	0	13	13
Markham	0	6	0	6
King	10	0	0	10
Vaughan	10	18	48	76
Caledon	63	22	44	129
3012	0	22	0	22
3014	35	0	0	35
3106	0	0	24	24
3151	12	0	21	33
3197	16	0	0	16
Brampton	274	222	883	1379
3325	0	0	62	62
3327	21	0	0	21
3328	0	0	48	48
3331	0	0	28	28
3336	0	0	12	12
3339	25	0	0	25
3340	0	0	95	95
3342	9	0	13	22
3343	0	0	23	23
3348	0	14	88	102
3349	0	0	47	47
3350	22	0	0	22
3351	23	19	0	42
3357	7	18	0	25
3360	26	0	0	26
3365	0	0	12	12
3368	0	0	49	49
3369	0	0	13	13
3370	16	0	0	16
3372	0	0	7	7
3375	0	0	47	47
3376	0	0	17	17
3381	26	9	34	69
3383	0	13	23	36
3417	29	21	0	50
3419	0	34	33	67
3423	6	0	37	43
3430	0	14	0	14
3434	0	0	27	27
3436	0	0	33	33
3443	0	0	23	23
3455	0	0	7	7
3459	0	0	34	34
3462	5	0	0	5
3467	0	38	22	60
3469	0	0	13	13
3480	0	17	15	32
3483	0	24	0	24
3486	49	0	0	49
3495	0	0	9	9
3513	10	0	0	10
3514	0	0	11	11
Mississauga	168	79	740	987
Halton Hills	31	0	7	38
Milton	11	0	8	19
Oakville	10	0	33	43
Dundas	0	13	0	13
Hamilton	17	11	0	28
Kitchener	0	37	0	37
Cambridge	17	0	0	17
City of Guelph	17	0	54	71
Orangeville	22	0	0	22
Mono	0	12	0	12

Fri Feb 04 2022 13:34:03 GMT-0500 (Eastern Standard Time) - Run Time: 2683ms

Cross Tabulation Query Form - Trip - 2016 v1.1

Row: 2006 GTA zone of destination - gta06_dest
Column: 2006 GTA zone of origin - gta06_orig

Filters:

2006 GTA zone of origin - gta06_orig In 3007,3381,3459
and
Start time of trip - start_time In 600-859
and
Trip purpose of origin - purp_orig In H
and
Primary travel mode of trip - mode_prime In D,M,P,T,U
and
Planning district of destination - pd_dest In 34

Trip 2016

Table:

	3007	3381	3459
3012	0	22	0
3014	35	0	0
3106	0	0	24
3151	12	0	21
3197	16	0	0

Fri Feb 04 2022 13:41:47 GMT-0500 (Eastern Standard Time) - Run Time: 2683ms

Cross Tabulation Query Form - Trip - 2016 v1.1

Row: 2006 GTA zone of destination - gta06_dest
Column: 2006 GTA zone of origin - gta06_orig

Filters:

2006 GTA zone of origin - gta06_orig In 3007,3381,3459
and
Start time of trip - start_time In 600-859
and
Trip purpose of origin - purp_orig In H
and
Primary travel mode of trip - mode_prime In D,M,P,T,U
and
Planning district of destination - pd_dest In 35

Trip 2016

Table:

	3007	3381	3459
3325	0	0	62
3327	21	0	0
3328	0	0	48
3331	0	0	28
3336	0	0	12
3339	25	0	0
3340	0	0	95
3342	9	0	13
3343	0	0	23
3348	0	14	88
3349	0	0	47
3350	22	0	0
3351	23	19	0
3357	7	18	0
3360	26	0	0
3365	0	0	12
3368	0	0	49
3369	0	0	13
3370	16	0	0
3372	0	0	7
3375	0	0	47
3376	0	0	17
3381	26	9	34
3383	0	13	23
3417	29	21	0
3419	0	34	33
3423	6	0	37
3430	0	14	0
3434	0	0	27
3436	0	0	33
3443	0	0	23
3455	0	0	7
3459	0	0	34
3462	5	0	0
3467	0	38	22
3469	0	0	13
3480	0	17	15
3483	0	24	0
3486	49	0	0
3495	0	0	9
3513	10	0	0
3514	0	0	11
3514	0	0	11

12197, 12211, 12213 and 12231 Hurontario Street

7597-06

Residential Vehicular Site Traffic Distribution (PM Peak Hour)

Inbound

BA Group - EFS

2022-05-18

Fri Feb 04 2022 14:38:58 GMT-0500 (Eastern Standard Time) - Run Time: 3075ms

Fri Feb 04 2022 15:02:31 GMT-0500 (Eastern Standard Time) - Run Time: 3458ms

Fri Feb 04 2022 15:03:23 GMT-0500 (Eastern S

Cross Tabulation Query Form - Trip - 2016 v1.1

Cross Tabulation Query Form - Trip - 2016 v1.1

Cross Tabulation Query Form - Trip - 2016 v1.1

Row: Planning district of origin - pd_orig
Column: 2006 GTA zone of destination - gta06_dest

Row: 2006 GTA zone of origin - gta06_orig
Column: 2006 GTA zone of destination - gta06_dest

Row: 2006 GTA zone of origin - gta06_orig
Column: 2006 GTA zone of destination - gta06_

Filters:

2006 GTA zone of destination - gta06_dest In 3007,3381,3459
and
Start time of trip - start_time In 1500-1759
and
Trip purpose of destination - purp_dest In H
and
Primary travel mode of trip - mode_prime In D,M,P,T,U

Filters:

2006 GTA zone of destination - gta06_dest In 3007,3381,3459
and
Start time of trip - start_time In 1500-1759
and
Trip purpose of destination - purp_dest In H
and
Primary travel mode of trip - mode_prime In D,M,P,T,U
and
Planning district of origin - pd_orig In 34

Filters:

2006 GTA zone of destination - gta06_dest In 3007,3381,3459
and
Start time of trip - start_time In 1500-1759
and
Trip purpose of destination - purp_dest In H
and
Primary travel mode of trip - mode_prime In D,M,P,T,U
and
Planning district of origin - pd_orig In 35

Trip 2016

Table:

	3007	3381	3459	Total
PD 1 of Toronto	67	0	66	133
PD 3 of Toronto	0	17	40	57
PD 7 of Toronto	0	0	36	36
PD 8 of Toronto	0	0	39	39
PD 9 of Toronto	6	0	30	36
PD 10 of Toronto	17	0	39	56
PD 11 of Toronto	0	11	0	11
PD 16 of Toronto	0	0	15	15
Aurora	11	0	0	11
Richmond Hill	0	0	13	13
Markham	0	6	0	6
King	10	0	0	10
Vaughan	10	6	23	39
Caledon	12	22	44	78
3012	0	22	0	22
3106	0	0	24	24
3151	12	0	21	33
Brampton	355	123	1172	1650
3325	0	0	135	135
3328	0	0	48	48
3331	29	0	28	57
3336	0	0	12	12
3337	12	0	0	12
3339	25	0	21	46
3340	0	0	173	173
3342	20	0	13	33
3348	0	14	88	102
3349	0	0	43	43
3350	22	0	0	22
3357	30	0	0	30
3363	0	0	18	18
3368	0	0	28	28
3369	0	0	13	13
3370	22	18	26	66
3372	0	0	7	7
3375	0	0	68	68
3376	0	0	17	17
3381	49	6	87	142
3383	0	0	23	23
3384	0	0	17	17
3419	0	34	33	67
3423	6	0	37	43
3429	0	0	18	18
3430	0	14	0	14
3436	0	0	18	18
3443	0	0	23	23
3455	0	0	7	7
3458	29	0	17	46
3459	0	0	19	19
3461	23	0	29	52
3462	39	30	0	69
3467	0	0	68	68
3480	0	0	15	15
3486	26	6	0	32
3495	14	0	16	30
3513	10	0	0	10
3514	0	0	11	11
Mississauga	131	67	495	693
Halton Hills	11	0	7	18
Milton	0	0	12	12
Oakville	23	0	13	36
Hamilton	0	11	0	11
Kitchener	0	37	0	37
City of Guelph	17	0	54	71

Trip 2016

Table:

	3007	3381	3459	
	3012	0	22	0
	3106	0	0	24
	3151	12	0	21

Trip 2016

Table:

	3007	3381	3459	
	3325	0	0	135
	3328	0	0	48
	3331	29	0	28
	3336	0	0	12
	3337	12	0	0
	3339	25	0	21
	3340	0	0	173
	3342	20	0	13
	3348	0	14	88
	3349	0	0	43
	3350	22	0	0
	3357	30	0	0
	3363	0	0	18
	3368	0	0	28
	3369	0	0	13
	3370	22	18	26
	3372	0	0	7
	3375	0	0	68
	3376	0	0	17
	3381	49	6	87
	3383	0	0	23
	3384	0	0	17
	3419	0	34	33
	3423	6	0	37
	3429	0	0	18
	3430	0	14	0
	3436	0	0	18
	3443	0	0	23
	3455	0	0	7
	3458	29	0	17
	3459	0	0	19
	3461	23	0	29
	3462	39	30	0
	3467	0	0	68
	3480	0	0	15
	3486	26	6	0
	3495	14	0	16
	3513	10	0	0
	3514	0	0	11

12197, 12211, 12213 and 12231 Hurontario Street

7597-06

Residential Vehicular Site Traffic Distribution (AM Peak Hour)

Outbound

BA Group - EFS

2022-05-18

Zone	Trips	%	Traffic Volume Allocation					TOTAL
			NORTH Hurontario	SOUTH Hurontario	EAST Hwy 410	EAST Mayfield	WEST Mayfield	
PD 1 of Toronto	53	2%			100%			100%
PD 2 of Toronto	23	1%			100%			100%
PD 3 of Toronto	40	1%			100%			100%
PD 7 of Toronto	41	1%			100%			100%
PD 8 of Toronto	85	3%			100%			100%
PD 9 of Toronto	39	1%			100%			100%
PD 10 of Toronto	33	1%			100%			100%
PD 11 of Toronto	11	0%			100%			100%
PD 16 of Toronto	15	0%			100%			100%
Newmarket	8	0%			100%			100%
Richmond Hill	13	0%			100%			100%
Markham	6	0%			100%			100%
King	10	0%				100%		100%
Vaughan	76	2%			50%	50%		100%
3012	22	1%	40%			60%		100%
3014	35	1%	50%			50%		100%
3106	24	1%	90%				10%	100%
3151	33	1%	50%			50%		100%
3197	16	0%	50%			50%		100%
3325	62	2%		100%				100%
3327	21	1%	50%	50%				100%
3328	48	1%	50%	50%				100%
3331	28	1%	50%	50%				100%
3336	12	0%	20%	80%				100%
3339	25	1%		50%	50%			100%
3340	95	3%		100%				100%
3342	22	1%		100%				100%
3343	23	1%		100%				100%
3348	102	3%		100%				100%
3349	47	1%		100%				100%
3350	22	1%		100%				100%
3351	42	1%		100%				100%
3357	25	1%	50%	50%				100%
3360	26	1%		100%				100%
3365	12	0%		100%				100%
3368	49	2%		100%				100%
3369	13	0%		100%				100%
3370	16	0%		100%				100%
3372	7	0%		100%				100%
3375	47	1%		100%				100%
3376	17	1%		100%				100%
3381	69	2%	100%					100%
3383	36	1%		100%				100%
3417	50	2%		80%	20%			100%
3419	67	2%	50%	50%				100%
3423	43	1%		50%	50%			100%
3430	14	0%		100%				100%
3434	27	1%		100%				100%
3436	33	1%		100%				100%
3443	23	1%			100%			100%
3455	7	0%		100%				100%
3459	34	1%	100%					100%
3462	5	0%		100%				100%
3467	60	2%		100%				100%
3469	13	0%	50%			50%		100%
3480	32	1%		100%				100%
3483	24	1%		100%				100%
3486	49	2%		100%				100%
3495	9	0%		100%				100%
3513	10	0%		50%	50%			100%
3514	11	0%		50%	50%			100%
Mississauga	987	30%		50%	50%			100%
Haltoun Hills	38	1%	40%	20%			40%	100%
Milton	19	1%		70%	30%			100%
Oakville	43	1%		50%	50%			100%
Dundas	13	0%		45%	45%		10%	100%
Hamilton	28	1%		10%	90%			100%
Kitchener	37	1%	50%		50%			100%
Cambridge	17	1%		80%	10%		10%	100%
City of Guelph	71	2%	50%		10%		50%	100%
Orangeville	22	1%	100%					100%
Mono	12	0%	100%					100%
TOTAL TRIPS	3247	100%						

Assumed Split

Route Split Totals						TOTAL
NORTH Hurontario	SOUTH Hurontario	EAST Hwy 410	EAST Mayfield	WEST Mayfield		
0.00%	0.00%	1.63%	0.00%	0.00%		1.6%
0.00%	0.00%	0.71%	0.00%	0.00%		0.7%
0.00%	0.00%	1.23%	0.00%	0.00%		1.2%
0.00%	0.00%	1.26%	0.00%	0.00%		1.3%
0.00%	0.00%	2.62%	0.00%	0.00%		2.6%
0.00%	0.00%	1.20%	0.00%	0.00%		1.2%
0.00%	0.00%	1.02%	0.00%	0.00%		1.0%
0.00%	0.00%	0.34%	0.00%	0.00%		0.3%
0.00%	0.00%	0.46%	0.00%	0.00%		0.5%
0.00%	0.00%	0.25%	0.00%	0.00%		0.2%
0.00%	0.00%	0.40%	0.00%	0.00%		0.4%
0.00%	0.00%	0.18%	0.00%	0.00%		0.2%
0.00%	0.00%	0.00%	0.31%	0.00%		0.3%
0.00%	0.00%	1.17%	1.17%	0.00%		2.3%
0.27%	0.00%	0.00%	0.41%	0.00%		0.7%
0.54%	0.00%	0.00%	0.54%	0.00%		1.1%
0.67%	0.00%	0.00%	0.00%	0.07%		0.7%
0.51%	0.00%	0.00%	0.51%	0.00%		1.0%
0.25%	0.00%	0.00%	0.25%	0.00%		0.5%
0.00%	1.91%	0.00%	0.00%	0.00%		1.9%
0.32%	0.32%	0.00%	0.00%	0.00%		0.6%
0.74%	0.74%	0.00%	0.00%	0.00%		1.5%
0.43%	0.43%	0.00%	0.00%	0.00%		0.9%
0.07%	0.30%	0.00%	0.00%	0.00%		0.4%
0.00%	0.38%	0.38%	0.00%	0.00%		0.8%
0.00%	2.93%	0.00%	0.00%	0.00%		2.9%
0.00%	0.68%	0.00%	0.00%	0.00%		0.7%
0.00%	0.71%	0.00%	0.00%	0.00%		0.7%
0.00%	3.14%	0.00%	0.00%	0.00%		3.1%
0.00%	1.45%	0.00%	0.00%	0.00%		1.4%
0.00%	0.68%	0.00%	0.00%	0.00%		0.7%
0.00%	1.29%	0.00%	0.00%	0.00%		1.3%
0.38%	0.38%	0.00%	0.00%	0.00%		0.8%
0.00%	0.80%	0.00%	0.00%	0.00%		0.8%
0.00%	0.37%	0.00%	0.00%	0.00%		0.4%
0.00%	1.51%	0.00%	0.00%	0.00%		1.5%
0.00%	0.40%	0.00%	0.00%	0.00%		0.4%
0.00%	0.49%	0.00%	0.00%	0.00%		0.5%
0.00%	0.22%	0.00%	0.00%	0.00%		0.2%
0.00%	1.45%	0.00%	0.00%	0.00%		1.4%
0.00%	0.52%	0.00%	0.00%	0.00%		0.5%
2.13%	0.00%	0.00%	0.00%	0.00%		2.1%
0.00%	1.11%	0.00%	0.00%	0.00%		1.1%
0.00%	1.23%	0.31%	0.00%	0.00%		1.5%
1.03%	1.03%	0.00%	0.00%	0.00%		2.1%
0.00%	0.66%	0.66%	0.00%	0.00%		1.3%
0.00%	0.43%	0.00%	0.00%	0.00%		0.4%
0.00%	0.83%	0.00%	0.00%	0.00%		0.8%
0.00%	1.02%	0.00%	0.00%	0.00%		1.0%
0.00%	0.00%	0.71%	0.00%	0.00%		0.7%
0.00%	0.22%	0.00%	0.00%	0.00%		0.2%
1.05%	0.00%	0.00%	0.00%	0.00%		1.0%
0.00%	0.15%	0.00%	0.00%	0.00%		0.2%
0.00%	1.85%	0.00%	0.00%	0.00%		1.8%
0.20%	0.00%	0.00%	0.20%	0.00%		0.4%
0.00%	0.99%	0.00%	0.00%	0.00%		1.0%
0.00%	0.74%	0.00%	0.00%	0.00%		0.7%
0.00%	1.51%	0.00%	0.00%	0.00%		1.5%
0.00%	0.28%	0.00%	0.00%	0.00%		0.3%
0.00%	0.15%	0.15%	0.00%	0.00%		0.3%
0.00%	0.17%	0.17%	0.00%	0.00%		0.3%
0.00%	15.20%	15.20%	0.00%	0.00%		30.4%
0.47%	0.23%	0.00%	0.00%	0.47%		1.2%
0.00%	0.41%	0.18%	0.00%	0.00%		0.6%
0.00%	0.66%	0.66%	0.00%	0.00%		1.3%
0.00%	0.18%	0.18%	0.00%	0.04%		0.4%
0.00%	0.09%	0.78%	0.00%	0.00%		0.9%
0.57%	0.00%	0.57%	0.00%	0.00%		1.1%
0.00%	0.42%	0.05%	0.00%	0.05%		0.5%
1.09%	0.00%	0.00%	0.00%	1.09%		2.2%
0.68%	0.00%	0.00%	0.00%	0.00%		0.7%
0.37%	0.00%	0.00%	0.00%	0.00%		0.4%
11.5%	50.7%	32.5%	3.4%	1.7%		66.4%

10%	50%	35%	5%	0%	100%
-----	-----	-----	----	----	------

12197, 12211, 12213 and 12231 Hurontario Street
7597-06

Residential Vehicular Site Traffic Distribution (PM Peak Hour)

Inbound

BA Group - EFS

2022-05-18

Zone	Trips	%	Traffic Volume Allocation					TOTAL
			NORTH Hurontario	SOUTH Hurontario	EAST Hwy 410	EAST Mayfield	WEST Mayfield	
PD 1 of Toronto	133	4%			100%			100%
PD 3 of Toronto	57	2%			100%			100%
PD 7 of Toronto	36	1%			100%			100%
PD 8 of Toronto	39	1%			100%			100%
PD 9 of Toronto	36	1%			100%			100%
PD 10 of Toronto	56	2%			100%			100%
PD 11 of Toronto	11	0%			100%			100%
PD 16 of Toronto	15	0%			100%			100%
Aurora	11	0%			50%	50%		100%
Richmond Hill	13	0%			50%	50%		100%
Markham	6	0%			100%			100%
King	10	0%			50%	50%		100%
Vaughan	39	1%			50%	50%		100%
3012	22	1%			50%	50%		100%
3106	24	1%	100%					100%
3151	33	1%	50%			50%		100%
3325	135	4%		100%				100%
3328	48	2%		50%	50%			100%
3331	57	2%		50%	50%			100%
3336	12	0%		50%	50%			100%
3337	12	0%		20%	40%	40%		100%
3339	46	1%		40%	60%			100%
3340	173	6%		50%	50%			100%
3342	33	1%		50%	50%			100%
3348	102	3%		100%				100%
3349	43	1%		100%				100%
3350	22	1%		100%				100%
3357	30	1%		60%	40%			100%
3363	18	1%		80%	20%			100%
3368	28	1%		100%				100%
3369	13	0%		100%				100%
3370	66	2%		100%				100%
3372	7	0%		50%	50%			100%
3375	68	2%		100%				100%
3376	17	1%		100%				100%
3381	142	5%	50%	50%				100%
3383	23	1%		100%				100%
3384	17	1%	50%	50%				100%
3419	67	2%		40%	20%	40%		100%
3423	43	1%		50%	50%			100%
3429	18	1%		100%				100%
3430	14	0%		100%				100%
3436	18	1%		100%				100%
3443	23	1%			100%			100%
3455	7	0%	20%	80%				100%
3458	46	1%		100%				100%
3459	19	1%	50%	50%				100%
3461	52	2%		100%				100%
3462	69	2%		100%				100%
3467	68	2%		100%				100%
3480	15	0%		100%				100%
3486	32	1%		100%				100%
3495	30	1%		70%	30%			100%
3513	10	0%		100%				100%
3514	11	0%		100%				100%
Mississauga	693	23%		10%	90%			100%
Halton Hills	18	1%		50%	50%			100%
Milton	12	0%		40%	60%			100%
Oakville	36	1%			100%			100%
Hamilton	11	0%		20%	70%	10%		100%
Kitchener	37	1%		50%	50%			100%
City of Guelph	71	2%	100%					100%
TOTAL TRIPS	3073	100%						

Assumed Split

Route Split Totals					
NORTH Hurontario	SOUTH Hurontario	EAST Hwy 410	EAST Mayfield	WEST Mayfield	TOTAL
0.00%	0.00%	4.33%	0.00%	0.00%	4.3%
0.00%	0.00%	1.85%	0.00%	0.00%	1.9%
0.00%	0.00%	1.17%	0.00%	0.00%	1.2%
0.00%	0.00%	1.27%	0.00%	0.00%	1.3%
0.00%	0.00%	1.17%	0.00%	0.00%	1.2%
0.00%	0.00%	1.82%	0.00%	0.00%	1.8%
0.00%	0.00%	0.36%	0.00%	0.00%	0.4%
0.00%	0.00%	0.49%	0.00%	0.00%	0.5%
0.00%	0.00%	0.18%	0.18%	0.00%	0.4%
0.00%	0.00%	0.21%	0.21%	0.00%	0.4%
0.00%	0.00%	0.20%	0.00%	0.00%	0.2%
0.00%	0.00%	0.16%	0.16%	0.00%	0.3%
0.00%	0.00%	0.63%	0.63%	0.00%	1.3%
0.00%	0.00%	0.36%	0.36%	0.00%	0.7%
0.78%	0.00%	0.00%	0.00%	0.00%	0.8%
0.54%	0.00%	0.00%	0.54%	0.00%	1.1%
0.00%	4.39%	0.00%	0.00%	0.00%	4.4%
0.00%	0.78%	0.78%	0.00%	0.00%	1.6%
0.00%	0.93%	0.93%	0.00%	0.00%	1.9%
0.00%	0.20%	0.20%	0.00%	0.00%	0.4%
0.00%	0.08%	0.16%	0.16%	0.00%	0.4%
0.00%	0.60%	0.90%	0.00%	0.00%	1.5%
0.00%	2.81%	2.81%	0.00%	0.00%	5.6%
0.00%	0.54%	0.54%	0.00%	0.00%	1.1%
0.00%	3.32%	0.00%	0.00%	0.00%	3.3%
0.00%	1.40%	0.00%	0.00%	0.00%	1.4%
0.00%	0.72%	0.00%	0.00%	0.00%	0.7%
0.00%	0.59%	0.39%	0.00%	0.00%	1.0%
0.00%	0.47%	0.12%	0.00%	0.00%	0.6%
0.00%	0.91%	0.00%	0.00%	0.00%	0.9%
0.00%	0.42%	0.00%	0.00%	0.00%	0.4%
0.00%	2.15%	0.00%	0.00%	0.00%	2.1%
0.00%	0.11%	0.11%	0.00%	0.00%	0.2%
0.00%	2.21%	0.00%	0.00%	0.00%	2.2%
0.00%	0.55%	0.00%	0.00%	0.00%	0.6%
2.31%	2.31%	0.00%	0.00%	0.00%	4.6%
0.00%	0.75%	0.00%	0.00%	0.00%	0.7%
0.28%	0.28%	0.00%	0.00%	0.00%	0.6%
0.00%	0.87%	0.44%	0.87%	0.00%	2.2%
0.00%	0.70%	0.70%	0.00%	0.00%	1.4%
0.00%	0.59%	0.00%	0.00%	0.00%	0.6%
0.00%	0.46%	0.00%	0.00%	0.00%	0.5%
0.00%	0.59%	0.00%	0.00%	0.00%	0.6%
0.00%	0.00%	0.75%	0.00%	0.00%	0.7%
0.05%	0.18%	0.00%	0.00%	0.00%	0.2%
0.00%	1.50%	0.00%	0.00%	0.00%	1.5%
0.31%	0.31%	0.00%	0.00%	0.00%	0.6%
0.00%	1.69%	0.00%	0.00%	0.00%	1.7%
0.00%	2.25%	0.00%	0.00%	0.00%	2.2%
0.00%	2.21%	0.00%	0.00%	0.00%	2.2%
0.00%	0.49%	0.00%	0.00%	0.00%	0.5%
0.00%	1.04%	0.00%	0.00%	0.00%	1.0%
0.00%	0.68%	0.29%	0.00%	0.00%	1.0%
0.00%	0.00%	0.33%	0.00%	0.00%	0.3%
0.00%	0.00%	0.36%	0.00%	0.00%	0.4%
0.00%	2.26%	20.30%	0.00%	0.00%	22.6%
0.00%	0.29%	0.29%	0.00%	0.00%	0.6%
0.00%	0.16%	0.23%	0.00%	0.00%	0.4%
0.00%	0.00%	1.17%	0.00%	0.00%	1.2%
0.00%	0.07%	0.25%	0.00%	0.04%	0.4%
0.00%	0.60%	0.60%	0.00%	0.00%	1.2%
2.31%	0.00%	0.00%	0.00%	0.00%	2.3%
6.6%	43.4%	46.8%	3.1%	0.0%	73.8%

5%	45%	45%	5%	0%	100%
-----------	------------	------------	-----------	-----------	-------------

12197, 12211, 12213 and 12231 Hurontario Street

7597-06

Mode Split
 BA Group - EFS
 2022-05-18

2016 TTS DATA

Residential (AM Peak Period)

Fri Feb 04 2022 12:58:21 GMT-0500 (Eastern Standard Time)

Frequency Distribution Query Form - Trip - 2016 v1.1

Field: Primary travel mode of trip - mode_prime

Filters:

Start time of trip - start_time In 600-859
 and
 Trip purpose of origin - purp_orig In H
 and
 2006 GTA zone of origin - gta06_orig In 3007, 3381, 3459
 or
 Start time of trip - start_time In 600-859
 and
 Trip purpose of destination - purp_dest In H
 and
 2006 GTA zone of destination - gta06_dest In 3007, 3381, 3459

Table: Trip 2016

Row:	Count:	Expanded:	%
Transit excluding GO rail	11	176	4%
Cycle	1	18	0%
Auto driver	168	3004	66%
GO rail only	8	104	2%
Joint GO rail and local transi	2	28	1%
Auto passenger	24	377	8%
School bus	34	877	19%
Total:	248	4583	100%

Auto	66%
Auto Passenger	27%
Transit	7%
Pedestrian	0%
Cyclist	0%
Total	100%

Residential (PM Peak Period)

Fri Feb 04 2022 13:10:44 GMT-0500 (Eastern Standard Time)

Frequency Distribution Query Form - Trip - 2016 v1.1

Field: Primary travel mode of trip - mode_prime

Filters:

Start time of trip - start_time In 1500-1759
 and
 Trip purpose of origin - purp_orig In H
 and
 2006 GTA zone of origin - gta06_orig In 3007, 3381, 3459
 or
 Start time of trip - start_time In 1500-1759
 and
 Trip purpose of destination - purp_dest In H
 and
 2006 GTA zone of destination - gta06_dest In 3007, 3381, 3459

Table: Trip 2016

Row:	Count:	Expanded:	%
Transit excluding GO rail	12	478	9%
Auto driver	183	3479	68%
GO rail only	7	97	2%
Auto passenger	26	516	10%
School bus	24	521	10%
Walk	1	26	1%
Total:	253	5117	100%

Auto	68%
Auto Passenger	20%
Transit	11%
Pedestrian	1%
Cyclist	0%
Total	100%

Appendix I
Existing Signal Timing Plans

BA Consulting Group Ltd.
 300 – 45 St. Clair Ave. W.
 Toronto, ON
 M4V 1K9

Attention: Alain Wong

Subject: Request for Signal Timings

As per you request, the traffic signal timing for the requested intersection is as follows:

Hurontario Street at Collingwood Avenue / Highwood Road								
PHASE DIRECTION								
<i>Day Plan</i>	<i>Time</i>	<i>Plan</i>	2 <i>Hurontario Street - Northbound</i>	4 <i>Collingwood Avenue - Westbound</i>	6 <i>Hurontario Street - Southbound</i>	8 <i>Highwood Road - Eastbound</i>	<i>Cycle Length</i>	<i>Offset</i>
Sunday	0000-2400	Free	48	24	48	24	72	0
Weekdays	0000-2400	Free	48	24	48	24	72	0
Saturday	0000-2400	Free	48	24	48	24	72	0

Note 1: Four seconds Amber and two seconds all red for all phases

Note 2: Eight seconds pedestrian walk and 12 seconds pedestrian clearance for phase 2 and phase 6, if demanded

Note 3: Eight seconds pedestrian walk and 30 seconds pedestrian clearance for phase 4 and phase 8, if demanded

Note 4: Phase 4 and 8 are served if demanded

Note 5: This intersection is semi-actuated

Yours truly,



Carolyn Ricker – Traffic Signal Technologist
 Traffic Services – Public Works & Engineering
 Tel: (905) 874-2556 Fax: (905) 874-2599
carolyn.ricker@brampton.ca

Appendix J
Synchro Worksheets

Timings

2: Hurontario St & Collingwood Ave/Highwood Rd

Existing AM
Argo Summer Valley (7597-06)

	EBL	EBT	WBL	WBT	NBL	NBT	SBL	SBT	SBR	
Lane Configurations	↔	↔	↔	↔	↔	↔	↔	↔	↔	
Traffic Volume (vph)	50	25	15	5	20	615	60	905	25	
Future Volume (vph)	50	25	15	5	20	615	60	905	25	
Turn Type	Perm	NA	Perm	NA	Perm	NA	Perm	NA	Perm	
Protected Phases	4		8		2		6		6	
Permitted Phases	4		8		2		6		6	
Detector Phase	4	4	8	8	2	2	6	6	6	
Switch Phase										
Minimum Initial (s)	5.0	5.0	5.0	5.0	5.0	5.0	5.0	5.0	5.0	
Minimum Split (s)	44.0	44.0	44.0	44.0	26.0	26.0	26.0	26.0	26.0	
Total Split (s)	44.0	44.0	44.0	44.0	48.0	48.0	48.0	48.0	48.0	
Total Split (%)	47.8%	47.8%	47.8%	47.8%	52.2%	52.2%	52.2%	52.2%	52.2%	
Maximum Green (s)	38.0	38.0	38.0	38.0	42.0	42.0	42.0	42.0	42.0	
Yellow Time (s)	4.0	4.0	4.0	4.0	4.0	4.0	4.0	4.0	4.0	
All-Red Time (s)	2.0	2.0	2.0	2.0	2.0	2.0	2.0	2.0	2.0	
Lost Time Adjust (s)	0.0	0.0	0.0	0.0	0.0	0.0	0.0	0.0	0.0	
Total Lost Time (s)	6.0	6.0	6.0	6.0	6.0	6.0	6.0	6.0	6.0	
Lead/Lag										
Lead-Lag Optimize?										
Vehicle Extension (s)	3.0	3.0	3.0	3.0	3.0	3.0	3.0	3.0	3.0	
Minimum Gap (s)	3.0	3.0	3.0	3.0	3.0	3.0	3.0	3.0	3.0	
Time Before Reduce (s)	0.0	0.0	0.0	0.0	0.0	0.0	0.0	0.0	0.0	
Time To Reduce (s)	0.0	0.0	0.0	0.0	0.0	0.0	0.0	0.0	0.0	
Recall Mode	None	None	None	None	Max	Max	Max	Max	Max	
Walk Time (s)	8.0	8.0	8.0	8.0	8.0	8.0	8.0	8.0	8.0	
Flash Dont Walk (s)	30.0	30.0	30.0	30.0	12.0	12.0	12.0	12.0	12.0	
Pedestrian Calls (#/hr)	0	0	0	0	0	0	0	0	0	

Intersection Summary

Cycle Length: 92
Actuated Cycle Length: 65
Natural Cycle: 70
Control Type: Semi Act-Uncoord

Splits and Phases: 2: Hurontario St & Collingwood Ave/Highwood Rd

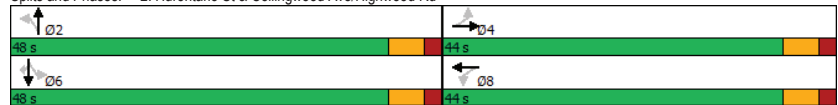

Queues

2: Hurontario St & Collingwood Ave/Highwood Rd

Existing AM
Argo Summer Valley (7597-06)

	EBL	EBT	WBL	WBT	NBL	NBT	SBL	SBT	SBR
Lane Group Flow (vph)	50	55	15	50	20	635	60	905	25
v/c Ratio	0.32	0.24	0.10	0.21	0.05	0.25	0.11	0.36	0.02
Control Delay	30.7	16.7	24.9	11.7	4.2	4.0	4.5	4.6	1.2
Queue Delay	0.0	0.0	0.0	0.0	0.0	0.0	0.0	0.0	0.0
Total Delay	30.7	16.7	24.9	11.7	4.2	4.0	4.5	4.6	1.2
Queue Length 50th (m)	5.3	2.6	1.5	0.5	0.6	11.8	1.9	18.9	0.0
Queue Length 95th (m)	13.8	10.9	6.1	8.3	2.8	21.0	6.1	32.3	1.5
Internal Link Dist (m)	343.0		60.2		420.4		84.7		
Turn Bay Length (m)					19.8	48.8		38.1	
Base Capacity (vph)	739	984	749	959	414	2516	571	2526	1202
Starvation Cap Reductn	0	0	0	0	0	0	0	0	0
Spillback Cap Reductn	0	0	0	0	0	0	0	0	0
Storage Cap Reductn	0	0	0	0	0	0	0	0	0
Reduced v/c Ratio	0.07	0.06	0.02	0.05	0.05	0.25	0.11	0.36	0.02

Intersection Summary

HCM Signalized Intersection Capacity Analysis
 2: Hurontario St & Collingwood Ave/Highwood Rd

Existing AM
 Argo Summer Valley (7597-06)

Movement	EBL	EBT	EBR	WBL	WBT	WBR	NBL	NBT	NBR	SBL	SBT	SBR
Lane Configurations	↔	↔		↔	↔		↔	↔		↔	↔	↔
Traffic Volume (vph)	50	25	30	15	5	45	20	615	20	60	905	25
Future Volume (vph)	50	25	30	15	5	45	20	615	20	60	905	25
Ideal Flow (vphpl)	1900	1900	1900	1900	1900	1900	1900	1900	1900	1900	1900	1900
Lane Width	3.5	3.7	3.5	3.5	3.7	3.5	3.5	3.7	3.5	3.5	3.7	3.5
Total Lost time (s)	6.0	6.0		6.0	6.0		6.0	6.0		6.0	6.0	6.0
Lane Util. Factor	1.00	1.00		1.00	1.00		1.00	0.95		1.00	0.95	1.00
Frt	1.00	0.92		1.00	0.86		1.00	1.00		1.00	1.00	0.85
Fit Protected	0.95	1.00		0.95	1.00		0.95	1.00		0.95	1.00	1.00
Satd. Flow (prot)	1653	1657		1684	1604		1700	3367		1767	3380	1597
Fit Permitted	0.72	1.00		0.72	1.00		0.31	1.00		0.41	1.00	1.00
Satd. Flow (perm)	1260	1657		1278	1604		554	3367		764	3380	1597
Peak-hour factor, PHF	1.00	1.00	1.00	1.00	1.00	1.00	1.00	1.00	1.00	1.00	1.00	1.00
Adj. Flow (vph)	50	25	30	15	5	45	20	615	20	60	905	25
RTOR Reduction (vph)	0	27	0	0	40	0	0	1	0	0	0	7
Lane Group Flow (vph)	50	28	0	15	10	0	20	634	0	60	905	18
Heavy Vehicles (%)	8%	7%	6%	6%	0%	4%	5%	8%	5%	1%	8%	0%
Turn Type	Perm	NA		Perm	NA		Perm	NA		Perm	NA	Perm
Protected Phases		4			8			2			6	
Permitted Phases	4			8			2			6		6
Actuated Green, G (s)	6.9	6.9		6.9	6.9		47.4	47.4		47.4	47.4	47.4
Effective Green, g (s)	6.9	6.9		6.9	6.9		47.4	47.4		47.4	47.4	47.4
Actuated g/C Ratio	0.10	0.10		0.10	0.10		0.71	0.71		0.71	0.71	0.71
Clearance Time (s)	6.0	6.0		6.0	6.0		6.0	6.0		6.0	6.0	6.0
Vehicle Extension (s)	3.0	3.0		3.0	3.0		3.0	3.0		3.0	3.0	3.0
Lane Grp Cap (vph)	131	172		133	166		396	2407		546	2416	1141
v/s Ratio Prot		0.02			0.01			0.19			c0.27	
v/s Ratio Perm	c0.04			0.01			0.04			0.08		0.01
v/c Ratio	0.38	0.16		0.11	0.06		0.05	0.26		0.11	0.37	0.02
Uniform Delay, d1	27.7	27.1		26.9	26.8		2.8	3.3		2.9	3.7	2.7
Progression Factor	1.00	1.00		1.00	1.00		1.00	1.00		1.00	1.00	1.00
Incremental Delay, d2	1.9	0.4		0.4	0.1		0.2	0.3		0.4	0.4	0.0
Delay (s)	29.6	27.5		27.3	26.9		3.0	3.6		3.3	4.1	2.7
Level of Service	C	C		C	C		A	A		A	A	A
Approach Delay (s)		28.5			27.0			3.6			4.0	
Approach LOS		C			C			A			A	
Intersection Summary												
HCM 2000 Control Delay		6.1										A
HCM 2000 Volume to Capacity ratio		0.38										
Actuated Cycle Length (s)		66.3						12.0				
Intersection Capacity Utilization		53.6%										A
Analysis Period (min)		15										

HCM Unsignalized Intersection Capacity Analysis
 3: Hillpath Cres/McAlpine Rd & Highwood Rd

Existing AM
 Argo Summer Valley (7597-06)

Movement	EBL	EBT	EBR	WBL	WBT	WBR	NBL	NBT	NBR	SBL	SBT	SBR
Lane Configurations		↔			↔			↔			↔	
Traffic Volume (veh/h)	0	100	5	0	55	0	10	0	0	0	0	0
Future Volume (Veh/h)	0	100	5	0	55	0	10	0	0	0	0	0
Sign Control		Free			Free			Stop			Stop	
Grade		0%			0%			0%			0%	
Peak Hour Factor	1.00	1.00	1.00	1.00	1.00	1.00	1.00	1.00	1.00	1.00	1.00	1.00
Hourly flow rate (vph)	0	100	5	0	55	0	10	0	0	0	0	0
Pedestrians												
Lane Width (m)												
Walking Speed (m/s)												
Percent Blockage												
Right turn flare (veh)												
Median type		None			None							
Median storage (veh)												
Upstream signal (m)		84										
pX, platoon unblocked												
vC, conflicting volume		55			105			158	158	102	158	160
vC1, stage 1 conf vol												55
vC2, stage 2 conf vol												
vCu, unblocked vol		55			105			158	158	102	158	160
tC, single (s)		4.1			4.1			7.1	6.5	6.2	7.1	6.5
tC, 2 stage (s)												
tF (s)		2.2			2.2			3.5	4.0	3.3	3.5	4.0
p0 queue free %		100			100			99	100	100	100	100
cM capacity (veh/h)		1563			1499			813	738	958	813	736
Direction, Lane #	EB 1	WB 1	NB 1	SB 1								
Volume Total	105	55	10	0								
Volume Left	0	0	10	0								
Volume Right	5	0	0	0								
cSH	1563	1499	813	1700								
Volume to Capacity	0.00	0.00	0.01	0.00								
Queue Length 95th (m)	0.0	0.0	0.3	0.0								
Control Delay (s)	0.0	0.0	9.5	0.0								
Lane LOS			A	A								
Approach Delay (s)	0.0	0.0	9.5	0.0								
Approach LOS			A	A								
Intersection Summary												
Average Delay			0.6									
Intersection Capacity Utilization			15.6%					ICU Level of Service				A
Analysis Period (min)			15									

Timings

2: Hurontario St & Collingwood Ave/Highwood Rd

Existing PM

Argo Summer Valley (7597-06)



Lane Group	EBL	EBT	WBL	WBT	NBL	NBT	SBL	SBT	SBR	
Lane Configurations	↔	↔	↔	↔	↔	↔	↔	↔	↔	
Traffic Volume (vph)	35	5	10	5	45	805	30	945	85	
Future Volume (vph)	35	5	10	5	45	805	30	945	85	
Turn Type	Perm	NA	Perm	NA	Perm	NA	Perm	NA	Perm	
Protected Phases	4		8		2		6		6	
Permitted Phases	4	8		2		6		6	6	
Detector Phase	4	4	8	8	2	2	6	6	6	
Switch Phase										
Minimum Initial (s)	5.0	5.0	5.0	5.0	5.0	5.0	5.0	5.0	5.0	
Minimum Split (s)	24.0	24.0	24.0	24.0	26.0	26.0	26.0	26.0	26.0	
Total Split (s)	24.0	24.0	24.0	24.0	48.0	48.0	48.0	48.0	48.0	
Total Split (%)	33.3%	33.3%	33.3%	33.3%	66.7%	66.7%	66.7%	66.7%	66.7%	
Yellow Time (s)	4.0	4.0	4.0	4.0	4.0	4.0	4.0	4.0	4.0	
All-Red Time (s)	2.0	2.0	2.0	2.0	2.0	2.0	2.0	2.0	2.0	
Lost Time Adjust (s)	0.0	0.0	0.0	0.0	0.0	0.0	0.0	0.0	0.0	
Total Lost Time (s)	6.0	6.0	6.0	6.0	6.0	6.0	6.0	6.0	6.0	
Lead/Lag										
Lead-Lag Optimize?										
Recall Mode	None	None	None	None	Max	Max	Max	Max	Max	
Act Effct Green (s)	7.3	7.3	7.2	7.2	52.4	52.4	52.4	52.4	52.4	
Actuated g/C Ratio	0.11	0.11	0.11	0.11	0.81	0.81	0.81	0.81	0.81	
v/c Ratio	0.21	0.15	0.06	0.14	0.10	0.28	0.06	0.33	0.06	
Control Delay	28.3	14.0	25.0	15.1	4.1	3.3	3.8	3.5	1.2	
Queue Delay	0.0	0.0	0.0	0.0	0.0	0.0	0.0	0.0	0.0	
Total Delay	28.3	14.0	25.0	15.1	4.1	3.3	3.8	3.5	1.2	
LOS	C	B	C	B	A	A	A	A	A	
Approach Delay	21.7		17.9		3.3		3.3			
Approach LOS	C		B		A		A			

Intersection Summary

Cycle Length: 72
 Actuated Cycle Length: 64.4
 Natural Cycle: 50
 Control Type: Semi Act-Uncoord
 Maximum v/c Ratio: 0.33
 Intersection Signal Delay: 4.2
 Intersection LOS: A
 Intersection Capacity Utilization 53.9%
 ICU Level of Service A
 Analysis Period (min) 15

Splits and Phases: 2: Hurontario St & Collingwood Ave/Highwood Rd

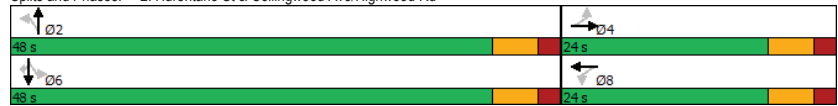

Queues

2: Hurontario St & Collingwood Ave/Highwood Rd

Existing PM

Argo Summer Valley (7597-06)



Lane Group	EBL	EBT	WBL	WBT	NBL	NBT	SBL	SBT	SBR
Lane Group Flow (vph)	35	30	10	25	45	825	30	945	85
v/c Ratio	0.21	0.15	0.06	0.14	0.10	0.28	0.06	0.33	0.06
Control Delay	28.3	14.0	25.0	15.1	4.1	3.3	3.8	3.5	1.2
Queue Delay	0.0	0.0	0.0	0.0	0.0	0.0	0.0	0.0	0.0
Total Delay	28.3	14.0	25.0	15.1	4.1	3.3	3.8	3.5	1.2
Queue Length 50th (m)	4.3	0.6	1.2	0.6	1.4	15.6	0.9	18.9	0.0
Queue Length 95th (m)	10.5	6.6	4.6	6.1	4.8	25.8	3.4	31.1	3.3
Internal Link Dist (m)	343.0		60.2		420.4		84.7		
Turn Bay Length (m)					19.8		48.8		38.1
Base Capacity (vph)	412	477	429	425	449	2901	506	2882	1315
Starvation Cap Reductn	0	0	0	0	0	0	0	0	0
Spillback Cap Reductn	0	0	0	0	0	0	0	0	0
Storage Cap Reductn	0	0	0	0	0	0	0	0	0
Reduced v/c Ratio	0.08	0.06	0.02	0.06	0.10	0.28	0.06	0.33	0.06

Intersection Summary

HCM Signalized Intersection Capacity Analysis
 2: Hurontario St & Collingwood Ave/Highwood Rd

Existing PM
 Argo Summer Valley (7597-06)

Movement	EBL	EBT	EBR	WBL	WBT	WBR	NBL	NBT	NBR	SBL	SBT	SBR
Lane Configurations	↔	↔	↔	↔	↔	↔	↔	↔	↔	↔	↔	↔
Traffic Volume (vph)	35	5	25	10	5	20	45	805	20	30	945	85
Future Volume (vph)	35	5	25	10	5	20	45	805	20	30	945	85
Ideal Flow (vphpl)	1900	1900	1900	1900	1900	1900	1900	1900	1900	1900	1900	1900
Lane Width	3.5	3.7	3.5	3.5	3.7	3.5	3.5	3.7	3.5	3.5	3.7	3.5
Total Lost time (s)	6.0	6.0		6.0	6.0		6.0	6.0		6.0	6.0	6.0
Lane Util. Factor	1.00	1.00		1.00	1.00		1.00	0.95		1.00	0.95	1.00
Frt	1.00	0.88		1.00	0.88		1.00	1.00		1.00	1.00	0.85
Fit Protected	0.95	1.00		0.95	1.00		0.95	1.00		0.95	1.00	1.00
Satd. Flow (prot)	1715	1640		1785	1468		1750	3567		1733	3544	1597
Fit Permitted	0.82	1.00		0.82	1.00		0.30	1.00		0.34	1.00	1.00
Satd. Flow (perm)	1474	1640		1534	1468		553	3567		622	3544	1597
Peak-hour factor, PHF	1.00	1.00	1.00	1.00	1.00	1.00	1.00	1.00	1.00	1.00	1.00	1.00
Adj. Flow (vph)	35	5	25	10	5	20	45	805	20	30	945	85
RTOR Reduction (vph)	0	23	0	0	19	0	0	2	0	0	0	22
Lane Group Flow (vph)	35	7	0	10	6	0	45	823	0	30	945	63
Heavy Vehicles (%)	2%	0%	3%	0%	40%	9%	2%	2%	0%	3%	3%	0%
Bus Blockages (#/hr)	5	0	0	0	0	0	0	0	0	0	0	0
Turn Type	Perm	NA		Perm	NA		Perm	NA		Perm	NA	Perm
Protected Phases		4			8			2			6	
Permitted Phases	4			8			2			6		6
Actuated Green, G (s)	4.9	4.9		4.9	4.9		49.9	49.9		49.9	49.9	49.9
Effective Green, g (s)	4.9	4.9		4.9	4.9		49.9	49.9		49.9	49.9	49.9
Actuated g/C Ratio	0.07	0.07		0.07	0.07		0.75	0.75		0.75	0.75	0.75
Clearance Time (s)	6.0	6.0		6.0	6.0		6.0	6.0		6.0	6.0	6.0
Vehicle Extension (s)	3.0	3.0		3.0	3.0		3.0	3.0		3.0	3.0	3.0
Lane Grp Cap (vph)	108	120		112	107		413	2664		464	2647	1192
v/s Ratio Prot		0.00			0.00			0.23			c0.27	
v/s Ratio Perm	c0.02			0.01			0.08			0.05		0.04
v/c Ratio	0.32	0.06		0.09	0.06		0.11	0.31		0.06	0.36	0.05
Uniform Delay, d1	29.4	28.8		28.9	28.8		2.3	2.8		2.2	2.9	2.2
Progression Factor	1.00	1.00		1.00	1.00		1.00	1.00		1.00	1.00	1.00
Incremental Delay, d2	1.7	0.2		0.3	0.2		0.5	0.3		0.3	0.4	0.1
Delay (s)	31.1	29.0		29.2	29.0		2.9	3.1		2.5	3.3	2.3
Level of Service	C	C		C	C		A	A		A	A	A
Approach Delay (s)		30.1			29.1			3.1			3.2	
Approach LOS		C			C			A			A	
Intersection Summary												
HCM 2000 Control Delay		4.4										A
HCM 2000 Volume to Capacity ratio		0.35										
Actuated Cycle Length (s)		66.8						12.0				
Intersection Capacity Utilization		53.9%										A
Analysis Period (min)		15										
c Critical Lane Group												

HCM Unsignalized Intersection Capacity Analysis
 3: Hillpath Cres/McAlpine Rd & Highwood Rd

Existing PM
 Argo Summer Valley (7597-06)

Movement	EBL	EBT	EBR	WBL	WBT	WBR	NBL	NBT	NBR	SBL	SBT	SBR
Lane Configurations		↔			↔			↔			↔	
Traffic Volume (veh/h)	0	40	15	0	30	0	5	0	0	0	0	0
Future Volume (Veh/h)	0	40	15	0	30	0	5	0	0	0	0	0
Sign Control		Free			Free			Stop			Stop	
Grade		0%			0%			0%			0%	
Peak Hour Factor	1.00	1.00	1.00	1.00	1.00	1.00	1.00	1.00	1.00	1.00	1.00	1.00
Hourly flow rate (vph)	0	40	15	0	30	0	5	0	0	0	0	0
Pedestrians												
Lane Width (m)												
Walking Speed (m/s)												
Percent Blockage												
Right turn flare (veh)												
Median type		None			None							
Median storage (veh)												
Upstream signal (m)		84										
pX, platoon unblocked												
vC, conflicting volume	30			55			78	78	48	78	85	30
vC1, stage 1 conf vol												
vC2, stage 2 conf vol												
vCu, unblocked vol	30			55			78	78	48	78	85	30
tC, single (s)	4.1			4.1			7.2	6.5	6.2	7.1	6.5	6.2
tC, 2 stage (s)												
tF (s)	2.2			2.2			3.6	4.0	3.3	3.5	4.0	3.3
p0 queue free %	100			100			99	100	100	100	100	100
cM capacity (veh/h)	1596			1563			883	817	1027	916	809	1050
Direction, Lane #	EB 1	WB 1	NB 1	SB 1								
Volume Total	55	30	5	0								
Volume Left	0	0	5	0								
Volume Right	15	0	0	0								
cSH	1596	1563	883	1700								
Volume to Capacity	0.00	0.00	0.01	0.00								
Queue Length 95th (m)	0.0	0.0	0.1	0.0								
Control Delay (s)	0.0	0.0	9.1	0.0								
Lane LOS			A	A								
Approach Delay (s)	0.0	0.0	9.1	0.0								
Approach LOS			A	A								
Intersection Summary												
Average Delay			0.5									
Intersection Capacity Utilization			13.3%									A
Analysis Period (min)			15									

Timings Future Background AM (2027)
 2: Hurontario St & Collingwood Ave/Highwood Rd Argo Summer Valley (7597-06)

	EBL	EBT	WBL	WBT	NBL	NBT	SBL	SBT	SBR
Lane Configurations	↔	↔	↔	↔	↔	↔	↔	↔	↔
Traffic Volume (vph)	50	25	15	5	20	695	60	1020	25
Future Volume (vph)	50	25	15	5	20	695	60	1020	25
Turn Type	Perm	NA	Perm	NA	Perm	NA	Perm	NA	Perm
Protected Phases	4		8		2		6		6
Permitted Phases	4		8		2		6		6
Detector Phase	4	4	8	8	2	2	6	6	6
Switch Phase									
Minimum Initial (s)	5.0	5.0	5.0	5.0	5.0	5.0	5.0	5.0	5.0
Minimum Split (s)	44.0	44.0	44.0	44.0	26.0	26.0	26.0	26.0	26.0
Total Split (s)	44.0	44.0	44.0	44.0	48.0	48.0	48.0	48.0	48.0
Total Split (%)	47.8%	47.8%	47.8%	47.8%	52.2%	52.2%	52.2%	52.2%	52.2%
Maximum Green (s)	38.0	38.0	38.0	38.0	42.0	42.0	42.0	42.0	42.0
Yellow Time (s)	4.0	4.0	4.0	4.0	4.0	4.0	4.0	4.0	4.0
All-Red Time (s)	2.0	2.0	2.0	2.0	2.0	2.0	2.0	2.0	2.0
Lost Time Adjust (s)	0.0	0.0	0.0	0.0	0.0	0.0	0.0	0.0	0.0
Total Lost Time (s)	6.0	6.0	6.0	6.0	6.0	6.0	6.0	6.0	6.0
Lead/Lag									
Lead-Lag Optimize?									
Vehicle Extension (s)	3.0	3.0	3.0	3.0	3.0	3.0	3.0	3.0	3.0
Minimum Gap (s)	3.0	3.0	3.0	3.0	3.0	3.0	3.0	3.0	3.0
Time Before Reduce (s)	0.0	0.0	0.0	0.0	0.0	0.0	0.0	0.0	0.0
Time To Reduce (s)	0.0	0.0	0.0	0.0	0.0	0.0	0.0	0.0	0.0
Recall Mode	None	None	None	None	Max	Max	Max	Max	Max
Walk Time (s)	8.0	8.0	8.0	8.0	8.0	8.0	8.0	8.0	8.0
Flash Dont Walk (s)	30.0	30.0	30.0	30.0	12.0	12.0	12.0	12.0	12.0
Pedestrian Calls (#/hr)	0	0	0	0	0	0	0	0	0

Intersection Summary	
Cycle Length:	92
Actuated Cycle Length:	65
Natural Cycle:	70
Control Type:	Semi Act-Uncoord



Queues Future Background AM (2027)
 2: Hurontario St & Collingwood Ave/Highwood Rd Argo Summer Valley (7597-06)

	EBL	EBT	WBL	WBT	NBL	NBT	SBL	SBT	SBR
Lane Group Flow (vph)	50	55	15	50	20	715	60	1020	25
v/c Ratio	0.32	0.24	0.10	0.21	0.06	0.28	0.11	0.40	0.02
Control Delay	30.7	16.7	24.9	11.7	4.3	4.1	4.6	4.9	1.2
Queue Delay	0.0	0.0	0.0	0.0	0.0	0.0	0.0	0.0	0.0
Total Delay	30.7	16.7	24.9	11.7	4.3	4.1	4.6	4.9	1.2
Queue Length 50th (m)	5.3	2.6	1.5	0.5	0.6	13.8	1.9	22.5	0.0
Queue Length 95th (m)	13.8	10.9	6.1	8.3	2.8	24.0	6.2	37.7	1.5
Internal Link Dist (m)	343.0		60.2		420.4		84.7		
Turn Bay Length (m)					19.8		48.8		38.1
Base Capacity (vph)	739	984	749	959	359	2518	528	2526	1202
Starvation Cap Reductn	0	0	0	0	0	0	0	0	0
Spillback Cap Reductn	0	0	0	0	0	0	0	0	0
Storage Cap Reductn	0	0	0	0	0	0	0	0	0
Reduced v/c Ratio	0.07	0.06	0.02	0.05	0.06	0.28	0.11	0.40	0.02

Intersection Summary

HCM Signalized Intersection Capacity Analysis
2: Hurontario St & Collingwood Ave/Highwood Rd

Future Background AM (2027)
Argo Summer Valley (7597-06)

Movement	EBL	EBT	EBR	WBL	WBT	WBR	NBL	NBT	NBR	SBL	SBT	SBR
Lane Configurations	↔	↔		↔	↔		↔	↔		↔	↔	↔
Traffic Volume (vph)	50	25	30	15	5	45	20	695	20	60	1020	25
Future Volume (vph)	50	25	30	15	5	45	20	695	20	60	1020	25
Ideal Flow (vphpl)	1900	1900	1900	1900	1900	1900	1900	1900	1900	1900	1900	1900
Lane Width	3.5	3.7	3.5	3.5	3.7	3.5	3.5	3.7	3.5	3.5	3.7	3.5
Total Lost time (s)	6.0	6.0		6.0	6.0		6.0	6.0		6.0	6.0	6.0
Lane Util. Factor	1.00	1.00		1.00	1.00		1.00	0.95		1.00	0.95	1.00
Frt	1.00	0.92		1.00	0.86		1.00	1.00		1.00	1.00	0.85
Fit Protected	0.95	1.00		0.95	1.00		0.95	1.00		0.95	1.00	1.00
Satd. Flow (prot)	1653	1657		1684	1604		1700	3368		1767	3380	1597
Fit Permitted	0.72	1.00		0.72	1.00		0.27	1.00		0.38	1.00	1.00
Satd. Flow (perm)	1260	1657		1278	1604		481	3368		707	3380	1597
Peak-hour factor, PHF	1.00	1.00	1.00	1.00	1.00	1.00	1.00	1.00	1.00	1.00	1.00	1.00
Adj. Flow (vph)	50	25	30	15	5	45	20	695	20	60	1020	25
RTOR Reduction (vph)	0	27	0	0	40	0	0	1	0	0	0	7
Lane Group Flow (vph)	50	28	0	15	10	0	20	714	0	60	1020	18
Heavy Vehicles (%)	8%	7%	6%	6%	0%	4%	5%	8%	5%	1%	8%	0%
Turn Type	Perm	NA		Perm	NA		Perm	NA		Perm	NA	Perm
Protected Phases		4			8			2			6	
Permitted Phases		4			8			2			6	
Actuated Green, G (s)	6.9	6.9		6.9	6.9		47.4	47.4		47.4	47.4	47.4
Effective Green, g (s)	6.9	6.9		6.9	6.9		47.4	47.4		47.4	47.4	47.4
Actuated g/C Ratio	0.10	0.10		0.10	0.10		0.71	0.71		0.71	0.71	0.71
Clearance Time (s)	6.0	6.0		6.0	6.0		6.0	6.0		6.0	6.0	6.0
Vehicle Extension (s)	3.0	3.0		3.0	3.0		3.0	3.0		3.0	3.0	3.0
Lane Grp Cap (vph)	131	172		133	166		343	2407		505	2416	1141
v/s Ratio Prot		0.02			0.01			0.21			c0.30	
v/s Ratio Perm	c0.04			0.01			0.04			0.08		0.01
v/c Ratio	0.38	0.16		0.11	0.06		0.06	0.30		0.12	0.42	0.02
Uniform Delay, d1	27.7	27.1		26.9	26.8		2.8	3.4		2.9	3.9	2.7
Progression Factor	1.00	1.00		1.00	1.00		1.00	1.00		1.00	1.00	1.00
Incremental Delay, d2	1.9	0.4		0.4	0.1		0.3	0.3		0.5	0.5	0.0
Delay (s)	29.6	27.5		27.3	26.9		3.1	3.7		3.4	4.4	2.7
Level of Service	C	C		C	C		A	A		A	A	A
Approach Delay (s)		28.5			27.0			3.7			4.3	
Approach LOS		C			C			A			A	
Intersection Summary												
HCM 2000 Control Delay		6.1										A
HCM 2000 Volume to Capacity ratio		0.42										
Actuated Cycle Length (s)		66.3						12.0				
Intersection Capacity Utilization		56.8%										B
Analysis Period (min)		15										

HCM Unsignalized Intersection Capacity Analysis
3: Hillpath Cres/McAlpine Rd & Highwood Rd

Future Background AM (2027)
Argo Summer Valley (7597-06)

Movement	EBL	EBT	EBR	WBL	WBT	WBR	NBL	NBT	NBR	SBL	SBT	SBR
Lane Configurations		↔			↔			↔			↔	
Traffic Volume (veh/h)	0	100	5	0	55	0	10	0	0	0	0	0
Future Volume (Veh/h)	0	100	5	0	55	0	10	0	0	0	0	0
Sign Control		Free			Free			Stop			Stop	
Grade		0%			0%			0%			0%	
Peak Hour Factor	1.00	1.00	1.00	1.00	1.00	1.00	1.00	1.00	1.00	1.00	1.00	1.00
Hourly flow rate (vph)	0	100	5	0	55	0	10	0	0	0	0	0
Pedestrians												
Lane Width (m)												
Walking Speed (m/s)												
Percent Blockage												
Right turn flare (veh)												
Median type		None			None							
Median storage (veh)												
Upstream signal (m)		84										
pX, platoon unblocked												
vC, conflicting volume		55			105			158	158	102	158	160
vC1, stage 1 conf vol												55
vC2, stage 2 conf vol												
vCu, unblocked vol		55			105			158	158	102	158	160
tC, single (s)		4.1			4.1			7.1	6.5	6.2	7.1	6.5
tC, 2 stage (s)												
tF (s)		2.2			2.2			3.5	4.0	3.3	3.5	4.0
p0 queue free %		100			100			99	100	100	100	100
cM capacity (veh/h)		1563			1499			813	738	958	813	736
Direction, Lane #	EB 1	WB 1	NB 1	SB 1								
Volume Total	105	55	10	0								
Volume Left	0	0	10	0								
Volume Right	5	0	0	0								
cSH	1563	1499	813	1700								
Volume to Capacity	0.00	0.00	0.01	0.00								
Queue Length 95th (m)	0.0	0.0	0.3	0.0								
Control Delay (s)	0.0	0.0	9.5	0.0								
Lane LOS			A	A								
Approach Delay (s)	0.0	0.0	9.5	0.0								
Approach LOS			A	A								
Intersection Summary												
Average Delay			0.6									
Intersection Capacity Utilization			15.6%					ICU Level of Service				A
Analysis Period (min)			15									

Timings Future Background PM (2027)
 2: Hurontario St & Collingwood Ave/Highwood Rd Argo Summer Valley (7597-06)

	↖	→	↗	←	↖	↑	↗	↓	↖	
Lane Group	EBL	EBT	WBL	WBT	NBL	NBT	SBL	SBT	SBR	
Lane Configurations	↖	↗	↖	↗	↖	↗	↖	↗	↖	
Traffic Volume (vph)	35	5	10	5	45	910	30	1065	85	
Future Volume (vph)	35	5	10	5	45	910	30	1065	85	
Turn Type	Perm	NA	Perm	NA	Perm	NA	Perm	NA	Perm	
Protected Phases	4		8		2		6		6	
Permitted Phases	4	8		2		6		6		
Detector Phase	4	4	8	8	2	2	6	6	6	
Switch Phase										
Minimum Initial (s)	5.0	5.0	5.0	5.0	5.0	5.0	5.0	5.0	5.0	
Minimum Split (s)	44.0	44.0	44.0	44.0	26.0	26.0	26.0	26.0	26.0	
Total Split (s)	24.0	24.0	24.0	24.0	48.0	48.0	48.0	48.0	48.0	
Total Split (%)	33.3%	33.3%	33.3%	33.3%	66.7%	66.7%	66.7%	66.7%	66.7%	
Yellow Time (s)	4.0	4.0	4.0	4.0	4.0	4.0	4.0	4.0	4.0	
All-Red Time (s)	2.0	2.0	2.0	2.0	2.0	2.0	2.0	2.0	2.0	
Lost Time Adjust (s)	0.0	0.0	0.0	0.0	0.0	0.0	0.0	0.0	0.0	
Total Lost Time (s)	6.0	6.0	6.0	6.0	6.0	6.0	6.0	6.0	6.0	
Lead/Lag										
Lead-Lag Optimize?										
Recall Mode	None	None	None	None	Max	Max	Max	Max	Max	
Act Effct Green (s)	7.2	7.2	7.1	7.1	52.2	52.2	52.2	52.2	52.2	
Actuated g/C Ratio	0.11	0.11	0.11	0.11	0.81	0.81	0.81	0.81	0.81	
v/c Ratio	0.21	0.14	0.06	0.14	0.12	0.32	0.07	0.37	0.06	
Control Delay	28.2	14.0	24.9	15.1	4.4	3.5	3.9	3.8	1.2	
Queue Delay	0.0	0.0	0.0	0.0	0.0	0.0	0.0	0.0	0.0	
Total Delay	28.2	14.0	24.9	15.1	4.4	3.5	3.9	3.8	1.2	
LOS	C	B	C	B	A	A	A	A	A	
Approach Delay	21.6		17.9		3.5		3.6			
Approach LOS	C		B		A		A			

Intersection Summary
 Cycle Length: 72
 Actuated Cycle Length: 64.2
 Natural Cycle: 70
 Control Type: Semi Act-Uncoord
 Maximum v/c Ratio: 0.37
 Intersection Signal Delay: 4.3 Intersection LOS: A
 Intersection Capacity Utilization 56.0% ICU Level of Service B
 Analysis Period (min) 15

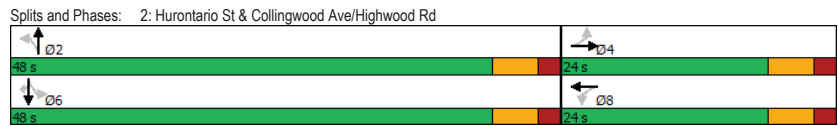

Queues Future Background PM (2027)
 2: Hurontario St & Collingwood Ave/Highwood Rd Argo Summer Valley (7597-06)

	↖	→	↗	←	↖	↑	↗	↓	↖	
Lane Group	EBL	EBT	WBL	WBT	NBL	NBT	SBL	SBT	SBR	
Lane Group Flow (vph)	35	30	10	25	45	930	30	1065	85	
v/c Ratio	0.21	0.14	0.06	0.14	0.12	0.32	0.07	0.37	0.06	
Control Delay	28.2	14.0	24.9	15.1	4.4	3.5	3.9	3.8	1.2	
Queue Delay	0.0	0.0	0.0	0.0	0.0	0.0	0.0	0.0	0.0	
Total Delay	28.2	14.0	24.9	15.1	4.4	3.5	3.9	3.8	1.2	
Queue Length 50th (m)	4.3	0.6	1.2	0.6	1.4	18.3	0.9	22.4	0.0	
Queue Length 95th (m)	10.5	6.6	4.6	6.1	4.9	30.1	3.4	36.3	3.3	
Internal Link Dist (m)	343.0		60.2		420.4		84.7			
Turn Bay Length (m)					19.8		48.8		38.1	
Base Capacity (vph)	413	478	430	426	389	2901	451	2880	1313	
Starvation Cap Reductn	0	0	0	0	0	0	0	0	0	
Spillback Cap Reductn	0	0	0	0	0	0	0	0	0	
Storage Cap Reductn	0	0	0	0	0	0	0	0	0	
Reduced v/c Ratio	0.08	0.06	0.02	0.06	0.12	0.32	0.07	0.37	0.06	
Intersection Summary										

HCM Signalized Intersection Capacity Analysis
2: Hurontario St & Collingwood Ave/Highwood Rd

Future Background PM (2027)
Argo Summer Valley (7597-06)

Movement	EBL	EBT	EBR	WBL	WBT	WBR	NBL	NBT	NBR	SBL	SBT	SBR
Lane Configurations	↔	↔	↔	↔	↔	↔	↔	↔	↔	↔	↔	↔
Traffic Volume (vph)	35	5	25	10	5	20	45	910	20	30	1065	85
Future Volume (vph)	35	5	25	10	5	20	45	910	20	30	1065	85
Ideal Flow (vphpl)	1900	1900	1900	1900	1900	1900	1900	1900	1900	1900	1900	1900
Lane Width	3.5	3.7	3.5	3.5	3.7	3.5	3.5	3.7	3.5	3.5	3.7	3.5
Total Lost time (s)	6.0	6.0		6.0	6.0		6.0	6.0		6.0	6.0	6.0
Lane Util. Factor	1.00	1.00		1.00	1.00		1.00	0.95		1.00	0.95	1.00
Frt	1.00	0.88		1.00	0.88		1.00	1.00		1.00	1.00	0.85
Fit Protected	0.95	1.00		0.95	1.00		0.95	1.00		0.95	1.00	1.00
Satd. Flow (prot)	1715	1640		1785	1468		1750	3569		1733	3544	1597
Fit Permitted	0.82	1.00		0.82	1.00		0.26	1.00		0.31	1.00	1.00
Satd. Flow (perm)	1474	1640		1534	1468		478	3569		557	3544	1597
Peak-hour factor, PHF	1.00	1.00	1.00	1.00	1.00	1.00	1.00	1.00	1.00	1.00	1.00	1.00
Adj. Flow (vph)	35	5	25	10	5	20	45	910	20	30	1065	85
RTOR Reduction (vph)	0	23	0	0	19	0	0	1	0	0	0	22
Lane Group Flow (vph)	35	7	0	10	6	0	45	929	0	30	1065	63
Heavy Vehicles (%)	2%	0%	3%	0%	40%	9%	2%	2%	0%	3%	3%	0%
Bus Blockages (#/hr)	5	0	0	0	0	0	0	0	0	0	0	0
Turn Type	Perm	NA		Perm	NA		Perm	NA		Perm	NA	Perm
Protected Phases		4			8			2			6	
Permitted Phases	4			8			2			6		6
Actuated Green, G (s)	4.9	4.9		4.9	4.9		49.7	49.7		49.7	49.7	49.7
Effective Green, g (s)	4.9	4.9		4.9	4.9		49.7	49.7		49.7	49.7	49.7
Actuated g/C Ratio	0.07	0.07		0.07	0.07		0.75	0.75		0.75	0.75	0.75
Clearance Time (s)	6.0	6.0		6.0	6.0		6.0	6.0		6.0	6.0	6.0
Vehicle Extension (s)	3.0	3.0		3.0	3.0		3.0	3.0		3.0	3.0	3.0
Lane Grp Cap (vph)	108	120		112	108		356	2663		415	2644	1191
v/s Ratio Prot		0.00			0.00			0.26			c0.30	
v/s Ratio Perm	c0.02			0.01			0.09			0.05		0.04
v/c Ratio	0.32	0.06		0.09	0.06		0.13	0.35		0.07	0.40	0.05
Uniform Delay, d1	29.3	28.7		28.8	28.7		2.4	2.9		2.3	3.1	2.2
Progression Factor	1.00	1.00		1.00	1.00		1.00	1.00		1.00	1.00	1.00
Incremental Delay, d2	1.7	0.2		0.3	0.2		0.7	0.4		0.3	0.5	0.1
Delay (s)	31.0	28.9		29.1	28.9		3.1	3.3		2.6	3.5	2.3
Level of Service	C	C		C	C		A	A		A	A	A
Approach Delay (s)		30.0			29.0			3.3			3.4	
Approach LOS		C			C			A			A	
Intersection Summary												
HCM 2000 Control Delay		4.5					HCM 2000 Level of Service				A	
HCM 2000 Volume to Capacity ratio		0.40										
Actuated Cycle Length (s)		66.6					Sum of lost time (s)				12.0	
Intersection Capacity Utilization		56.0%					ICU Level of Service				B	
Analysis Period (min)		15										
c Critical Lane Group												

HCM Unsignalized Intersection Capacity Analysis
3: Hillpath Cres/McAlpine Rd & Highwood Rd

Future Background PM (2027)
Argo Summer Valley (7597-06)

Movement	EBL	EBT	EBR	WBL	WBT	WBR	NBL	NBT	NBR	SBL	SBT	SBR
Lane Configurations		↔			↔			↔			↔	
Traffic Volume (veh/h)	0	40	15	0	30	0	5	0	0	0	0	0
Future Volume (Veh/h)	0	40	15	0	30	0	5	0	0	0	0	0
Sign Control		Free			Free			Stop			Stop	
Grade		0%			0%			0%			0%	
Peak Hour Factor	1.00	1.00	1.00	1.00	1.00	1.00	1.00	1.00	1.00	1.00	1.00	1.00
Hourly flow rate (vph)	0	40	15	0	30	0	5	0	0	0	0	0
Pedestrians												
Lane Width (m)												
Walking Speed (m/s)												
Percent Blockage												
Right turn flare (veh)												
Median type		None			None							
Median storage (veh)												
Upstream signal (m)		84										
pX, platoon unblocked												
vC, conflicting volume	30			55			78	78	48	78	85	30
vC1, stage 1 conf vol												
vC2, stage 2 conf vol												
vCu, unblocked vol	30			55			78	78	48	78	85	30
tC, single (s)	4.1			4.1			7.2	6.5	6.2	7.1	6.5	6.2
tC, 2 stage (s)												
tF (s)	2.2			2.2			3.6	4.0	3.3	3.5	4.0	3.3
p0 queue free %	100			100			99	100	100	100	100	100
cM capacity (veh/h)	1596			1563			883	817	1027	916	809	1050
Direction, Lane #	EB 1	WB 1	NB 1	SB 1								
Volume Total	55	30	5	0								
Volume Left	0	0	5	0								
Volume Right	15	0	0	0								
cSH	1596	1563	883	1700								
Volume to Capacity	0.00	0.00	0.01	0.00								
Queue Length 95th (m)	0.0	0.0	0.1	0.0								
Control Delay (s)	0.0	0.0	9.1	0.0								
Lane LOS			A	A								
Approach Delay (s)	0.0	0.0	9.1	0.0								
Approach LOS			A	A								
Intersection Summary												
Average Delay			0.5									
Intersection Capacity Utilization			13.3%				ICU Level of Service				A	
Analysis Period (min)			15									

Timings

2: Hurontario St & Collingwood Ave/Highwood Rd

Future Total AM (2027)

Argo Summer Valley (7597-06)

	EBL	EBT	WBL	WBT	NBL	NBT	SBL	SBT	SBR	
Lane Configurations	↔	↔	↔	↔	↔	↔	↔	↔	↔	
Traffic Volume (vph)	50	25	32	5	20	695	68	1020	25	
Future Volume (vph)	50	25	32	5	20	695	68	1020	25	
Turn Type	Perm	NA	Perm	NA	Perm	NA	Perm	NA	Perm	
Protected Phases	4		8		2		6		6	
Permitted Phases	4	8		2		6		6		
Detector Phase	4	4	8	8	2	2	6	6	6	
Switch Phase										
Minimum Initial (s)	5.0	5.0	5.0	5.0	5.0	5.0	5.0	5.0	5.0	
Minimum Split (s)	44.0	44.0	44.0	44.0	26.0	26.0	26.0	26.0	26.0	
Total Split (s)	44.0	44.0	44.0	44.0	48.0	48.0	48.0	48.0	48.0	
Total Split (%)	47.8%	47.8%	47.8%	47.8%	52.2%	52.2%	52.2%	52.2%	52.2%	
Maximum Green (s)	38.0	38.0	38.0	38.0	42.0	42.0	42.0	42.0	42.0	
Yellow Time (s)	4.0	4.0	4.0	4.0	4.0	4.0	4.0	4.0	4.0	
All-Red Time (s)	2.0	2.0	2.0	2.0	2.0	2.0	2.0	2.0	2.0	
Lost Time Adjust (s)	0.0	0.0	0.0	0.0	0.0	0.0	0.0	0.0	0.0	
Total Lost Time (s)	6.0	6.0	6.0	6.0	6.0	6.0	6.0	6.0	6.0	
Lead/Lag										
Lead-Lag Optimize?										
Vehicle Extension (s)	3.0	3.0	3.0	3.0	3.0	3.0	3.0	3.0	3.0	
Minimum Gap (s)	3.0	3.0	3.0	3.0	3.0	3.0	3.0	3.0	3.0	
Time Before Reduce (s)	0.0	0.0	0.0	0.0	0.0	0.0	0.0	0.0	0.0	
Time To Reduce (s)	0.0	0.0	0.0	0.0	0.0	0.0	0.0	0.0	0.0	
Recall Mode	None	None	None	None	Max	Max	Max	Max	Max	
Walk Time (s)	8.0	8.0	8.0	8.0	8.0	8.0	8.0	8.0	8.0	
Flash Dont Walk (s)	30.0	30.0	30.0	30.0	12.0	12.0	12.0	12.0	12.0	
Pedestrian Calls (#/hr)	0	0	0	0	0	0	0	0	0	

Intersection Summary

Cycle Length: 92

Actuated Cycle Length: 64.1

Natural Cycle: 70

Control Type: Semi Act-Uncoord

Splits and Phases: 2: Hurontario St & Collingwood Ave/Highwood Rd

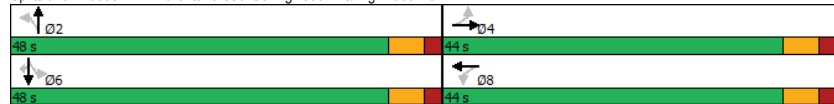

Queues

2: Hurontario St & Collingwood Ave/Highwood Rd

Future Total AM (2027)

Argo Summer Valley (7597-06)

	EBL	EBT	WBL	WBT	NBL	NBT	SBL	SBT	SBR
Lane Group Flow (vph)	50	55	32	66	20	721	68	1020	25
v/c Ratio	0.32	0.24	0.20	0.26	0.06	0.29	0.13	0.41	0.02
Control Delay	30.4	16.7	27.1	11.2	4.4	4.2	4.8	4.9	1.3
Queue Delay	0.0	0.0	0.0	0.0	0.0	0.0	0.0	0.0	0.0
Total Delay	30.4	16.7	27.1	11.2	4.4	4.2	4.8	4.9	1.3
Queue Length 50th (m)	5.3	2.6	3.3	0.5	0.6	13.9	2.2	22.5	0.0
Queue Length 95th (m)	13.9	10.9	10.0	9.4	2.8	24.4	6.9	38.0	1.5
Internal Link Dist (m)	343.0		60.2		420.4		84.7		
Turn Bay Length (m)					19.8		48.8		38.1
Base Capacity (vph)	737	995	758	971	357	2502	522	2511	1195
Starvation Cap Reductn	0	0	0	0	0	0	0	0	0
Spillback Cap Reductn	0	0	0	0	0	0	0	0	0
Storage Cap Reductn	0	0	0	0	0	0	0	0	0
Reduced v/c Ratio	0.07	0.06	0.04	0.07	0.06	0.29	0.13	0.41	0.02

Intersection Summary

HCM Signalized Intersection Capacity Analysis
 2: Hurontario St & Collingwood Ave/Highwood Rd

Future Total AM (2027)
 Argo Summer Valley (7597-06)

Movement	EBL	EBT	EBR	WBL	WBT	WBR	NBL	NBT	NBR	SBL	SBT	SBR
Lane Configurations	↔	↔		↔	↔		↔	↔		↔	↔	↔
Traffic Volume (vph)	50	25	30	32	5	61	20	695	26	68	1020	25
Future Volume (vph)	50	25	30	32	5	61	20	695	26	68	1020	25
Ideal Flow (vphpl)	1900	1900	1900	1900	1900	1900	1900	1900	1900	1900	1900	1900
Lane Width	3.5	3.7	3.5	3.5	3.7	3.5	3.5	3.7	3.5	3.5	3.7	3.5
Total Lost time (s)	6.0	6.0		6.0	6.0		6.0	6.0		6.0	6.0	6.0
Lane Util. Factor	1.00	1.00		1.00	1.00		1.00	0.95		1.00	0.95	1.00
Frt	1.00	0.92		1.00	0.86		1.00	0.99		1.00	1.00	0.85
Fit Protected	0.95	1.00		0.95	1.00		0.95	1.00		0.95	1.00	1.00
Satd. Flow (prot)	1653	1657		1684	1596		1700	3365		1767	3380	1597
Fit Permitted	0.71	1.00		0.72	1.00		0.27	1.00		0.38	1.00	1.00
Satd. Flow (perm)	1242	1657		1278	1596		481	3365		702	3380	1597
Peak-hour factor, PHF	1.00	1.00	1.00	1.00	1.00	1.00	1.00	1.00	1.00	1.00	1.00	1.00
Adj. Flow (vph)	50	25	30	32	5	61	20	695	26	68	1020	25
RTOR Reduction (vph)	0	27	0	0	55	0	0	1	0	0	0	7
Lane Group Flow (vph)	50	28	0	32	11	0	20	720	0	68	1020	18
Heavy Vehicles (%)	8%	7%	6%	6%	0%	4%	5%	8%	5%	1%	8%	0%
Turn Type	Perm	NA		Perm	NA		Perm	NA		Perm	NA	Perm
Protected Phases		4			8			2			6	
Permitted Phases	4			8			2			6		6
Actuated Green, G (s)	6.9	6.9		6.9	6.9		46.4	46.4		46.4	46.4	46.4
Effective Green, g (s)	6.9	6.9		6.9	6.9		46.4	46.4		46.4	46.4	46.4
Actuated g/C Ratio	0.11	0.11		0.11	0.11		0.71	0.71		0.71	0.71	0.71
Clearance Time (s)	6.0	6.0		6.0	6.0		6.0	6.0		6.0	6.0	6.0
Vehicle Extension (s)	3.0	3.0		3.0	3.0		3.0	3.0		3.0	3.0	3.0
Lane Grp Cap (vph)	131	175		135	168		341	2391		498	2401	1134
v/s Ratio Prot		0.02			0.01			0.21			c0.30	
v/s Ratio Perm	c0.04			0.03			0.04			0.10		0.01
v/c Ratio	0.38	0.16		0.24	0.07		0.06	0.30		0.14	0.42	0.02
Uniform Delay, d1	27.2	26.6		26.8	26.3		2.9	3.5		3.0	3.9	2.8
Progression Factor	1.00	1.00		1.00	1.00		1.00	1.00		1.00	1.00	1.00
Incremental Delay, d2	1.9	0.4		0.9	0.2		0.3	0.3		0.6	0.6	0.0
Delay (s)	29.1	27.0		27.7	26.5		3.2	3.8		3.6	4.5	2.8
Level of Service	C	C		C	C		A	A		A	A	A
Approach Delay (s)		28.0			26.9			3.8			4.4	
Approach LOS		C			C			A			A	
Intersection Summary												
HCM 2000 Control Delay		6.4										A
HCM 2000 Volume to Capacity ratio		0.42										
Actuated Cycle Length (s)		65.3						12.0				
Intersection Capacity Utilization		56.8%										B
Analysis Period (min)		15										

HCM Unsignalized Intersection Capacity Analysis
 3: Hillpath Cres/McAlpine Rd & Highwood Rd

Future Total AM (2027)
 Argo Summer Valley (7597-06)

Movement	EBL	EBT	EBR	WBL	WBT	WBR	NBL	NBT	NBR	SBL	SBT	SBR
Lane Configurations		↔			↔			↔			↔	
Traffic Volume (veh/h)	14	100	5	0	55	0	10	0	0	0	0	33
Future Volume (Veh/h)	14	100	5	0	55	0	10	0	0	0	0	33
Sign Control		Free			Free			Stop			Stop	
Grade		0%			0%			0%			0%	
Peak Hour Factor	1.00	1.00	1.00	1.00	1.00	1.00	1.00	1.00	1.00	1.00	1.00	1.00
Hourly flow rate (vph)	14	100	5	0	55	0	10	0	0	0	0	33
Pedestrians												
Lane Width (m)												
Walking Speed (m/s)												
Percent Blockage												
Right turn flare (veh)												
Median type		None			None							
Median storage (veh)												
Upstream signal (m)		84										
pX, platoon unblocked												
vC, conflicting volume	55			105			218	186	102	186	188	55
vC1, stage 1 conf vol												
vC2, stage 2 conf vol												
vCu, unblocked vol	55			105			218	186	102	186	188	55
tC, single (s)	4.1			4.1			7.1	6.5	6.2	7.1	6.5	6.2
tC, 2 stage (s)												
tF (s)	2.2			2.2			3.5	4.0	3.3	3.5	4.0	3.3
p0 queue free %	99			100			99	100	100	100	100	97
cM capacity (veh/h)	1563			1499			713	706	958	774	704	1018
Direction, Lane #	EB 1	WB 1	NB 1	SB 1								
Volume Total	119	55	10	33								
Volume Left	14	0	10	0								
Volume Right	5	0	0	33								
cSH	1563	1499	713	1018								
Volume to Capacity	0.01	0.00	0.01	0.03								
Queue Length 95th (m)	0.2	0.0	0.3	0.8								
Control Delay (s)	0.9	0.0	10.1	8.7								
Lane LOS	A		B	A								
Approach Delay (s)	0.9	0.0	10.1	8.7								
Approach LOS			B	A								
Intersection Summary												
Average Delay				2.3								
Intersection Capacity Utilization				26.9%				ICU Level of Service				A
Analysis Period (min)				15								

Timings

2: Hurontario St & Collingwood Ave/Highwood Rd

Future Total PM (2027)

Argo Summer Valley (7597-06)

	↖	→	↗	←	↖	↑	↘	↓	↙	
Lane Group	EBL	EBT	WBL	WBT	NBL	NBT	SBL	SBT	SBR	
Lane Configurations	↖	↗	↖	↗	↖	↗	↖	↗	↖	
Traffic Volume (vph)	35	5	23	5	45	910	50	1065	85	
Future Volume (vph)	35	5	23	5	45	910	50	1065	85	
Turn Type	Perm	NA	Perm	NA	Perm	NA	Perm	NA	Perm	
Protected Phases	4		8		2		6		6	
Permitted Phases	4		8		2		6		6	
Detector Phase	4	4	8	8	2	2	6	6	6	
Switch Phase										
Minimum Initial (s)	5.0	5.0	5.0	5.0	5.0	5.0	5.0	5.0	5.0	
Minimum Split (s)	44.0	44.0	44.0	44.0	26.0	26.0	26.0	26.0	26.0	
Total Split (s)	24.0	24.0	24.0	24.0	48.0	48.0	48.0	48.0	48.0	
Total Split (%)	33.3%	33.3%	33.3%	33.3%	66.7%	66.7%	66.7%	66.7%	66.7%	
Yellow Time (s)	4.0	4.0	4.0	4.0	4.0	4.0	4.0	4.0	4.0	
All-Red Time (s)	2.0	2.0	2.0	2.0	2.0	2.0	2.0	2.0	2.0	
Lost Time Adjust (s)	0.0	0.0	0.0	0.0	0.0	0.0	0.0	0.0	0.0	
Total Lost Time (s)	6.0	6.0	6.0	6.0	6.0	6.0	6.0	6.0	6.0	
Lead/Lag										
Lead-Lag Optimize?										
Recall Mode	None	None	None	None	Max	Max	Max	Max	Max	
Act Effct Green (s)	7.2	7.2	7.2	7.2	51.2	51.2	51.2	51.2	51.2	
Actuated g/C Ratio	0.11	0.11	0.11	0.11	0.81	0.81	0.81	0.81	0.81	
v/c Ratio	0.21	0.14	0.13	0.19	0.12	0.33	0.11	0.37	0.06	
Control Delay	27.7	13.9	26.0	13.7	4.4	3.5	4.2	3.8	1.2	
Queue Delay	0.0	0.0	0.0	0.0	0.0	0.0	0.0	0.0	0.0	
Total Delay	27.7	13.9	26.0	13.7	4.4	3.5	4.2	3.8	1.2	
LOS	C	B	C	B	A	A	A	A	A	
Approach Delay	21.3		18.5		3.6		3.6			
Approach LOS	C		B		A		A			

Intersection Summary

Cycle Length: 72	
Actuated Cycle Length: 63.3	
Natural Cycle: 70	
Control Type: Semi Act-Uncoord	
Maximum v/c Ratio: 0.37	
Intersection Signal Delay: 4.5	Intersection LOS: A
Intersection Capacity Utilization 57.2%	ICU Level of Service B
Analysis Period (min) 15	

Splits and Phases: 2: Hurontario St & Collingwood Ave/Highwood Rd

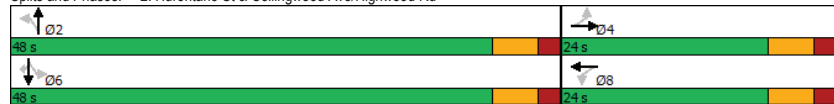

Queues

2: Hurontario St & Collingwood Ave/Highwood Rd

Future Total PM (2027)

Argo Summer Valley (7597-06)

	↖	→	↗	←	↖	↑	↘	↓	↙
Lane Group	EBL	EBT	WBL	WBT	NBL	NBT	SBL	SBT	SBR
Lane Group Flow (vph)	35	30	23	36	45	948	50	1065	85
v/c Ratio	0.21	0.14	0.13	0.19	0.12	0.33	0.11	0.37	0.06
Control Delay	27.7	13.9	26.0	13.7	4.4	3.5	4.2	3.8	1.2
Queue Delay	0.0	0.0	0.0	0.0	0.0	0.0	0.0	0.0	0.0
Total Delay	27.7	13.9	26.0	13.7	4.4	3.5	4.2	3.8	1.2
Queue Length 50th (m)	3.9	0.6	2.6	0.6	1.4	18.6	1.5	22.3	0.0
Queue Length 95th (m)	10.5	6.6	7.9	7.2	4.9	30.6	5.3	36.3	3.3
Internal Link Dist (m)	343.0		60.2		420.4		84.7		
Turn Bay Length (m)					19.8		48.8		38.1
Base Capacity (vph)	419	484	436	442	387	2881	441	2866	1308
Starvation Cap Reductn	0	0	0	0	0	0	0	0	0
Spillback Cap Reductn	0	0	0	0	0	0	0	0	0
Storage Cap Reductn	0	0	0	0	0	0	0	0	0
Reduced v/c Ratio	0.08	0.06	0.05	0.08	0.12	0.33	0.11	0.37	0.06

Intersection Summary

--

HCM Signalized Intersection Capacity Analysis
 2: Hurontario St & Collingwood Ave/Highwood Rd

Future Total PM (2027)
 Argo Summer Valley (7597-06)

Movement	EBL	EBT	EBR	WBL	WBT	WBR	NBL	NBT	NBR	SBL	SBT	SBR
Lane Configurations	↔	↔	↔	↔	↔	↔	↔	↔	↔	↔	↔	↔
Traffic Volume (vph)	35	5	25	23	5	31	45	910	38	50	1065	85
Future Volume (vph)	35	5	25	23	5	31	45	910	38	50	1065	85
Ideal Flow (vphpl)	1900	1900	1900	1900	1900	1900	1900	1900	1900	1900	1900	1900
Lane Width	3.5	3.7	3.5	3.5	3.7	3.5	3.5	3.7	3.5	3.5	3.7	3.5
Total Lost time (s)	6.0	6.0		6.0	6.0		6.0	6.0		6.0	6.0	6.0
Lane Util. Factor	1.00	1.00		1.00	1.00		1.00	0.95		1.00	0.95	1.00
Frt	1.00	0.88		1.00	0.87		1.00	0.99		1.00	1.00	0.85
Fit Protected	0.95	1.00		0.95	1.00		0.95	1.00		0.95	1.00	1.00
Satd. Flow (prot)	1715	1640		1785	1477		1750	3560		1733	3544	1597
Fit Permitted	0.82	1.00		0.82	1.00		0.26	1.00		0.30	1.00	1.00
Satd. Flow (perm)	1474	1640		1534	1477		478	3560		545	3544	1597
Peak-hour factor, PHF	1.00	1.00	1.00	1.00	1.00	1.00	1.00	1.00	1.00	1.00	1.00	1.00
Adj. Flow (vph)	35	5	25	23	5	31	45	910	38	50	1065	85
RTOR Reduction (vph)	0	23	0	0	29	0	0	3	0	0	0	22
Lane Group Flow (vph)	35	7	0	23	7	0	45	945	0	50	1065	63
Heavy Vehicles (%)	2%	0%	3%	0%	40%	9%	2%	2%	0%	3%	3%	0%
Bus Blockages (#/hr)	5	0	0	0	0	0	0	0	0	0	0	0
Turn Type	Perm	NA		Perm	NA		Perm	NA		Perm	NA	Perm
Protected Phases		4			8			2			6	
Permitted Phases	4			8			2			6		6
Actuated Green, G (s)	4.9	4.9		4.9	4.9		48.8	48.8		48.8	48.8	48.8
Effective Green, g (s)	4.9	4.9		4.9	4.9		48.8	48.8		48.8	48.8	48.8
Actuated g/C Ratio	0.07	0.07		0.07	0.07		0.74	0.74		0.74	0.74	0.74
Clearance Time (s)	6.0	6.0		6.0	6.0		6.0	6.0		6.0	6.0	6.0
Vehicle Extension (s)	3.0	3.0		3.0	3.0		3.0	3.0		3.0	3.0	3.0
Lane Grp Cap (vph)	109	122		114	110		355	2644		404	2632	1186
v/s Ratio Prot		0.00			0.00			0.27			c0.30	
v/s Ratio Perm	c0.02			0.01			0.09			0.09		0.04
v/c Ratio	0.32	0.06		0.20	0.07		0.13	0.36		0.12	0.40	0.05
Uniform Delay, d1	28.8	28.3		28.6	28.3		2.4	3.0		2.4	3.1	2.3
Progression Factor	1.00	1.00		1.00	1.00		1.00	1.00		1.00	1.00	1.00
Incremental Delay, d2	1.7	0.2		0.9	0.3		0.7	0.4		0.6	0.5	0.1
Delay (s)	30.5	28.4		29.4	28.5		3.1	3.3		3.0	3.6	2.3
Level of Service	C	C		C	C		A	A		A	A	A
Approach Delay (s)		29.6			28.9			3.3			3.5	
Approach LOS		C			C			A			A	
Intersection Summary												
HCM 2000 Control Delay		4.8										
HCM 2000 Volume to Capacity ratio		0.40										
Actuated Cycle Length (s)		65.7						12.0				
Intersection Capacity Utilization		57.2%										B
Analysis Period (min)		15										
c Critical Lane Group												

HCM Unsignalized Intersection Capacity Analysis
 3: Hillpath Cres/McAlpine Rd & Highwood Rd

Future Total PM (2027)
 Argo Summer Valley (7597-06)

Movement	EBL	EBT	EBR	WBL	WBT	WBR	NBL	NBT	NBR	SBL	SBT	SBR
Lane Configurations		↔			↔			↔			↔	
Traffic Volume (veh/h)	38	40	15	0	30	0	5	0	0	0	0	24
Future Volume (Veh/h)	38	40	15	0	30	0	5	0	0	0	0	24
Sign Control		Free			Free			Stop			Stop	
Grade		0%			0%			0%			0%	
Peak Hour Factor	1.00	1.00	1.00	1.00	1.00	1.00	1.00	1.00	1.00	1.00	1.00	1.00
Hourly flow rate (vph)	38	40	15	0	30	0	5	0	0	0	0	24
Pedestrians												
Lane Width (m)												
Walking Speed (m/s)												
Percent Blockage												
Right turn flare (veh)												
Median type		None			None							
Median storage (veh)												
Upstream signal (m)		84										
pX, platoon unblocked												
vC, conflicting volume	30				55			178	154	48	154	161
vC1, stage 1 conf vol												30
vC2, stage 2 conf vol												
vCu, unblocked vol	30				55			178	154	48	154	161
tC, single (s)	4.1				4.1			7.2	6.5	6.2	7.1	6.5
tC, 2 stage (s)												
tF (s)	2.2				2.2			3.6	4.0	3.3	3.5	4.0
p0 queue free %	98				100			99	100	100	100	98
cM capacity (veh/h)	1596				1563			728	724	1027	803	717
Direction, Lane #												
Volume Total	93	30	5	24								
Volume Left	38	0	5	0								
Volume Right	15	0	0	24								
cSH	1596	1563	728	1050								
Volume to Capacity	0.02	0.00	0.01	0.02								
Queue Length 95th (m)	0.6	0.0	0.2	0.5								
Control Delay (s)	3.1	0.0	10.0	8.5								
Lane LOS	A		A	A								
Approach Delay (s)	3.1	0.0	10.0	8.5								
Approach LOS			A	A								
Intersection Summary												
Average Delay									3.6			
Intersection Capacity Utilization									22.6%			ICU Level of Service
Analysis Period (min)									15			A

Timings Future Background AM (2032)
 2: Hurontario St & Collingwood Ave/Highwood Rd Argo Summer Valley (7597-06)

	↖	→	↘	←	↙	↑	↘	↓	↙
Lane Group	EBL	EBT	WBL	WBT	NBL	NBT	SBL	SBT	SBR
Lane Configurations	↖	↖	↖	↖	↖	↖	↖	↖	↖
Traffic Volume (vph)	50	25	15	5	20	988	60	1532	25
Future Volume (vph)	50	25	15	5	20	988	60	1532	25
Turn Type	Perm	NA	Perm	NA	Perm	NA	Perm	NA	Perm
Protected Phases	4		8		2		6		6
Permitted Phases	4		8		2		6		6
Detector Phase	4	4	8	8	2	2	6	6	6
Switch Phase									
Minimum Initial (s)	5.0	5.0	5.0	5.0	5.0	5.0	5.0	5.0	5.0
Minimum Split (s)	24.0	24.0	24.0	24.0	26.0	26.0	26.0	26.0	26.0
Total Split (s)	24.0	24.0	24.0	24.0	48.0	48.0	48.0	48.0	48.0
Total Split (%)	33.3%	33.3%	33.3%	33.3%	66.7%	66.7%	66.7%	66.7%	66.7%
Maximum Green (s)	18.0	18.0	18.0	18.0	42.0	42.0	42.0	42.0	42.0
Yellow Time (s)	4.0	4.0	4.0	4.0	4.0	4.0	4.0	4.0	4.0
All-Red Time (s)	2.0	2.0	2.0	2.0	2.0	2.0	2.0	2.0	2.0
Lost Time Adjust (s)	0.0	0.0	0.0	0.0	0.0	0.0	0.0	0.0	0.0
Total Lost Time (s)	6.0	6.0	6.0	6.0	6.0	6.0	6.0	6.0	6.0
Lead/Lag									
Lead-Lag Optimize?									
Vehicle Extension (s)	3.0	3.0	3.0	3.0	3.0	3.0	3.0	3.0	3.0
Minimum Gap (s)	3.0	3.0	3.0	3.0	3.0	3.0	3.0	3.0	3.0
Time Before Reduce (s)	0.0	0.0	0.0	0.0	0.0	0.0	0.0	0.0	0.0
Time To Reduce (s)	0.0	0.0	0.0	0.0	0.0	0.0	0.0	0.0	0.0
Recall Mode	None	None	None	None	Max	Max	Max	Max	Max
Walk Time (s)	8.0	8.0	8.0	8.0	8.0	8.0	8.0	8.0	8.0
Flash Dont Walk (s)	10.0	10.0	10.0	10.0	12.0	12.0	12.0	12.0	12.0
Pedestrian Calls (#/hr)	0	0	0	0	0	0	0	0	0

Intersection Summary	
Cycle Length:	72
Actuated Cycle Length:	65.8
Natural Cycle:	60
Control Type:	Semi Act-Uncoord

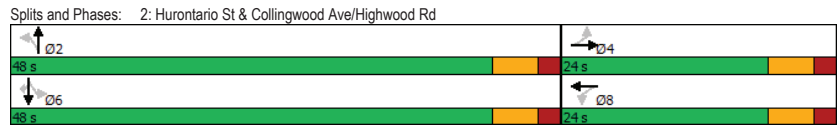

Queues Future Background AM (2032)
 2: Hurontario St & Collingwood Ave/Highwood Rd Argo Summer Valley (7597-06)

	↖	→	↘	←	↙	↑	↘	↓	↙
Lane Group	EBL	EBT	WBL	WBT	NBL	NBT	SBL	SBT	SBR
Lane Group Flow (vph)	50	55	15	50	20	1008	60	1532	25
v/c Ratio	0.32	0.24	0.10	0.21	0.11	0.40	0.16	0.61	0.02
Control Delay	30.7	16.7	24.8	11.6	5.9	4.8	5.4	6.8	0.8
Queue Delay	0.0	0.0	0.0	0.0	0.0	0.0	0.0	0.5	0.0
Total Delay	30.7	16.7	24.8	11.6	5.9	4.8	5.4	7.4	0.8
Queue Length 50th (m)	5.3	2.6	1.5	0.5	0.7	21.8	2.0	43.1	0.0
Queue Length 95th (m)	13.7	10.9	5.9	8.2	3.4	37.8	7.0	74.1	1.2
Internal Link Dist (m)	343.0		60.2		420.4		84.7		
Turn Bay Length (m)					19.8		48.8		38.1
Base Capacity (vph)	346	477	351	474	181	2524	380	2529	1206
Starvation Cap Reductn	0	0	0	0	0	0	0	511	0
Spillback Cap Reductn	0	0	0	0	0	0	0	0	0
Storage Cap Reductn	0	0	0	0	0	0	0	0	0
Reduced v/c Ratio	0.14	0.12	0.04	0.11	0.11	0.40	0.16	0.76	0.02

Intersection Summary

HCM Signalized Intersection Capacity Analysis
2: Hurontario St & Collingwood Ave/Highwood Rd

Future Background AM (2032)
Argo Summer Valley (7597-06)

Movement	EBL	EBT	EBR	WBL	WBT	WBR	NBL	NBT	NBR	SBL	SBT	SBR
Lane Configurations	↔	↔		↔	↔		↔	↔		↔	↔	↔
Traffic Volume (vph)	50	25	30	15	5	45	20	988	20	60	1532	25
Future Volume (vph)	50	25	30	15	5	45	20	988	20	60	1532	25
Ideal Flow (vphpl)	1900	1900	1900	1900	1900	1900	1900	1900	1900	1900	1900	1900
Lane Width	3.5	3.7	3.5	3.5	3.7	3.5	3.5	3.7	3.5	3.5	3.7	3.5
Total Lost time (s)	6.0	6.0		6.0	6.0		6.0	6.0		6.0	6.0	6.0
Lane Util. Factor	1.00	1.00		1.00	1.00		1.00	0.95		1.00	0.95	1.00
Frt	1.00	0.92		1.00	0.86		1.00	1.00		1.00	1.00	0.85
Fit Protected	0.95	1.00		0.95	1.00		0.95	1.00		0.95	1.00	1.00
Satd. Flow (prot)	1653	1657		1684	1604		1700	3372		1767	3380	1597
Fit Permitted	0.72	1.00		0.72	1.00		0.13	1.00		0.27	1.00	1.00
Satd. Flow (perm)	1260	1657		1278	1604		241	3372		508	3380	1597
Peak-hour factor, PHF	1.00	1.00	1.00	1.00	1.00	1.00	1.00	1.00	1.00	1.00	1.00	1.00
Adj. Flow (vph)	50	25	30	15	5	45	20	988	20	60	1532	25
RTOR Reduction (vph)	0	27	0	0	40	0	0	1	0	0	0	7
Lane Group Flow (vph)	50	28	0	15	10	0	20	1007	0	60	1532	18
Heavy Vehicles (%)	8%	7%	6%	6%	0%	4%	5%	8%	5%	1%	8%	0%
Turn Type	Perm	NA		Perm	NA		Perm	NA		Perm	NA	Perm
Protected Phases		4			8			2			6	
Permitted Phases	4			8			2			6		6
Actuated Green, G (s)	7.0	7.0		7.0	7.0		48.0	48.0		48.0	48.0	48.0
Effective Green, g (s)	7.0	7.0		7.0	7.0		48.0	48.0		48.0	48.0	48.0
Actuated g/C Ratio	0.10	0.10		0.10	0.10		0.72	0.72		0.72	0.72	0.72
Clearance Time (s)	6.0	6.0		6.0	6.0		6.0	6.0		6.0	6.0	6.0
Vehicle Extension (s)	3.0	3.0		3.0	3.0		3.0	3.0		3.0	3.0	3.0
Lane Grp Cap (vph)	131	173		133	167		172	2415		363	2421	1144
v/s Ratio Prot		0.02			0.01			0.30			c0.45	
v/s Ratio Perm	c0.04			0.01			0.08			0.12		0.01
v/c Ratio	0.38	0.16		0.11	0.06		0.12	0.42		0.17	0.63	0.02
Uniform Delay, d1	28.0	27.3		27.2	27.0		2.9	3.8		3.1	4.9	2.7
Progression Factor	1.00	1.00		1.00	1.00		1.00	1.00		1.00	1.00	1.00
Incremental Delay, d2	1.9	0.4		0.4	0.1		1.4	0.5		1.0	1.3	0.0
Delay (s)	29.8	27.8		27.6	27.2		4.3	4.4		4.0	6.2	2.7
Level of Service	C	C		C	C		A	A		A	A	A
Approach Delay (s)		28.8			27.3			4.4			6.1	
Approach LOS		C			C			A			A	
Intersection Summary												
HCM 2000 Control Delay		6.8					HCM 2000 Level of Service			A		
HCM 2000 Volume to Capacity ratio		0.60										
Actuated Cycle Length (s)		67.0					Sum of lost time (s)			12.0		
Intersection Capacity Utilization		69.3%					ICU Level of Service			C		
Analysis Period (min)		15										
c Critical Lane Group												

HCM Unsignalized Intersection Capacity Analysis
3: Hillpath Cres/McAlpine Rd & Highwood Rd

Future Background AM (2032)
Argo Summer Valley (7597-06)

Movement	EBL	EBT	EBR	WBL	WBT	WBR	NBL	NBT	NBR	SBL	SBT	SBR
Lane Configurations		↔			↔			↔			↔	
Traffic Volume (veh/h)	0	100	5	0	55	0	10	0	0	0	0	0
Future Volume (Veh/h)	0	100	5	0	55	0	10	0	0	0	0	0
Sign Control		Free			Free			Stop			Stop	
Grade		0%			0%			0%			0%	
Peak Hour Factor	1.00	1.00	1.00	1.00	1.00	1.00	1.00	1.00	1.00	1.00	1.00	1.00
Hourly flow rate (vph)	0	100	5	0	55	0	10	0	0	0	0	0
Pedestrians												
Lane Width (m)												
Walking Speed (m/s)												
Percent Blockage												
Right turn flare (veh)												
Median type		None			None							
Median storage (veh)												
Upstream signal (m)		84										
pX, platoon unblocked												
vC, conflicting volume		55			105			158	158	102	158	160
vC1, stage 1 conf vol												55
vC2, stage 2 conf vol												
vCu, unblocked vol		55			105			158	158	102	158	160
tC, single (s)		4.1			4.1			7.1	6.5	6.2	7.1	6.5
tC, 2 stage (s)												
tF (s)		2.2			2.2			3.5	4.0	3.3	3.5	4.0
p0 queue free %		100			100			99	100	100	100	100
cM capacity (veh/h)		1563			1499			813	738	958	813	736
												1018
Direction, Lane #	EB 1	WB 1	NB 1	SB 1								
Volume Total	105	55	10	0								
Volume Left	0	0	10	0								
Volume Right	5	0	0	0								
cSH	1563	1499	813	1700								
Volume to Capacity	0.00	0.00	0.01	0.00								
Queue Length 95th (m)	0.0	0.0	0.3	0.0								
Control Delay (s)	0.0	0.0	9.5	0.0								
Lane LOS			A	A								
Approach Delay (s)	0.0	0.0	9.5	0.0								
Approach LOS			A	A								
Intersection Summary												
Average Delay		0.6										
Intersection Capacity Utilization		15.6%			ICU Level of Service			A				
Analysis Period (min)		15										

Timings Future Background PM (2032)
 2: Hurontario St & Collingwood Ave/Highwood Rd Argo Summer Valley (7597-06)

	EBL	EBT	WBL	WBT	NBL	NBT	SBL	SBT	SBR	
Lane Configurations	↖	↗	↖	↗	↖	↗	↖	↗	↖	
Traffic Volume (vph)	35	5	10	5	45	1464	30	1842	85	
Future Volume (vph)	35	5	10	5	45	1464	30	1842	85	
Turn Type	Perm	NA	Perm	NA	Perm	NA	Perm	NA	Perm	
Protected Phases	4		8		2		6		6	
Permitted Phases	4		8		2		6		6	
Detector Phase	4	4	8	8	2	2	6	6	6	
Switch Phase										
Minimum Initial (s)	5.0	5.0	5.0	5.0	5.0	5.0	5.0	5.0	5.0	
Minimum Split (s)	24.0	24.0	24.0	24.0	26.0	26.0	26.0	26.0	26.0	
Total Split (s)	24.0	24.0	24.0	24.0	48.0	48.0	48.0	48.0	48.0	
Total Split (%)	33.3%	33.3%	33.3%	33.3%	66.7%	66.7%	66.7%	66.7%	66.7%	
Maximum Green (s)	18.0	18.0	18.0	18.0	42.0	42.0	42.0	42.0	42.0	
Yellow Time (s)	4.0	4.0	4.0	4.0	4.0	4.0	4.0	4.0	4.0	
All-Red Time (s)	2.0	2.0	2.0	2.0	2.0	2.0	2.0	2.0	2.0	
Lost Time Adjust (s)	0.0	0.0	0.0	0.0	0.0	0.0	0.0	0.0	0.0	
Total Lost Time (s)	6.0	6.0	6.0	6.0	6.0	6.0	6.0	6.0	6.0	
Lead/Lag										
Lead-Lag Optimize?										
Vehicle Extension (s)	3.0	3.0	3.0	3.0	3.0	3.0	3.0	3.0	3.0	
Minimum Gap (s)	3.0	3.0	3.0	3.0	3.0	3.0	3.0	3.0	3.0	
Time Before Reduce (s)	0.0	0.0	0.0	0.0	0.0	0.0	0.0	0.0	0.0	
Time To Reduce (s)	0.0	0.0	0.0	0.0	0.0	0.0	0.0	0.0	0.0	
Recall Mode	None	None	None	None	Max	Max	Max	Max	Max	
Walk Time (s)	8.0	8.0	8.0	8.0	8.0	8.0	8.0	8.0	8.0	
Flash Dont Walk (s)	10.0	10.0	10.0	10.0	12.0	12.0	12.0	12.0	12.0	
Pedestrian Calls (#/hr)	0	0	0	0	0	0	0	0	0	

Intersection Summary
 Cycle Length: 72
 Actuated Cycle Length: 64.4
 Natural Cycle: 65
 Control Type: Semi Act-Uncoord

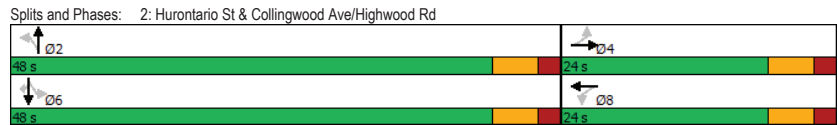

Queues Future Background PM (2032)
 2: Hurontario St & Collingwood Ave/Highwood Rd Argo Summer Valley (7597-06)

	EBL	EBT	WBL	WBT	NBL	NBT	SBL	SBT	SBR
Lane Group Flow (vph)	35	30	10	25	45	1484	30	1842	85
v/c Ratio	0.21	0.15	0.06	0.14	0.34	0.51	0.13	0.64	0.06
Control Delay	28.3	18.6	25.0	15.1	14.3	4.7	5.4	6.3	1.7
Queue Delay	0.0	0.0	0.0	0.0	0.0	0.0	0.0	0.6	0.0
Total Delay	28.3	18.6	25.0	15.1	14.3	4.7	5.4	6.9	1.7
Queue Length 50th (m)	4.3	1.8	1.2	0.6	1.7	37.1	1.0	56.3	0.6
Queue Length 95th (m)	10.5	7.8	4.6	6.1	#15.3	60.0	4.2	92.9	4.1
Internal Link Dist (m)	343.0		60.2		420.4		84.7		
Turn Bay Length (m)					19.8	48.8		38.1	
Base Capacity (vph)	412	470	429	425	133	2905	225	2882	1310
Starvation Cap Reductn	0	0	0	0	0	0	0	598	0
Spillback Cap Reductn	0	0	0	0	0	0	0	0	0
Storage Cap Reductn	0	0	0	0	0	0	0	0	0
Reduced v/c Ratio	0.08	0.06	0.02	0.06	0.34	0.51	0.13	0.81	0.06

Intersection Summary
 # 95th percentile volume exceeds capacity, queue may be longer.
 Queue shown is maximum after two cycles.

HCM Signalized Intersection Capacity Analysis
 2: Hurontario St & Collingwood Ave/Highwood Rd

Future Background PM (2032)
 Argo Summer Valley (7597-06)

Movement	EBL	EBT	EBR	WBL	WBT	WBR	NBL	NBT	NBR	SBL	SBT	SBR
Lane Configurations	↔	↔	↔	↔	↔	↔	↔	↔	↔	↔	↔	↔
Traffic Volume (vph)	35	5	25	10	5	20	45	1464	20	30	1842	85
Future Volume (vph)	35	5	25	10	5	20	45	1464	20	30	1842	85
Ideal Flow (vphpl)	1900	1900	1900	1900	1900	1900	1900	1900	1900	1900	1900	1900
Lane Width	3.5	3.7	3.5	3.5	3.7	3.5	3.5	3.7	3.5	3.5	3.7	3.5
Total Lost time (s)	6.0	6.0		6.0	6.0		6.0	6.0		6.0	6.0	6.0
Lane Util. Factor	1.00	1.00		1.00	1.00		1.00	0.95		1.00	0.95	1.00
Frt	1.00	0.88		1.00	0.88		1.00	1.00		1.00	1.00	0.85
Fit Protected	0.95	1.00		0.95	1.00		0.95	1.00		0.95	1.00	1.00
Satd. Flow (prot)	1715	1640		1785	1468		1750	3572		1733	3544	1597
Fit Permitted	0.82	1.00		0.82	1.00		0.09	1.00		0.15	1.00	1.00
Satd. Flow (perm)	1474	1640		1534	1468		163	3572		277	3544	1597
Peak-hour factor, PHF	1.00	1.00	1.00	1.00	1.00	1.00	1.00	1.00	1.00	1.00	1.00	1.00
Adj. Flow (vph)	35	5	25	10	5	20	45	1464	20	30	1842	85
RTOR Reduction (vph)	0	14	0	0	19	0	1	0	0	0	0	16
Lane Group Flow (vph)	35	16	0	10	6	0	45	1483	0	30	1842	69
Heavy Vehicles (%)	2%	0%	3%	0%	40%	9%	2%	2%	0%	3%	3%	0%
Bus Blockages (#/hr)	5	0	0	0	0	0	0	0	0	0	0	0
Turn Type	Perm	NA		Perm	NA		Perm	NA		Perm	NA	Perm
Protected Phases		4			8			2			6	
Permitted Phases	4			8			2			6		6
Actuated Green, G (s)	4.9	4.9		4.9	4.9		49.9	49.9		49.9	49.9	49.9
Effective Green, g (s)	4.9	4.9		4.9	4.9		49.9	49.9		49.9	49.9	49.9
Actuated g/C Ratio	0.07	0.07		0.07	0.07		0.75	0.75		0.75	0.75	0.75
Clearance Time (s)	6.0	6.0		6.0	6.0		6.0	6.0		6.0	6.0	6.0
Vehicle Extension (s)	3.0	3.0		3.0	3.0		3.0	3.0		3.0	3.0	3.0
Lane Grp Cap (vph)	108	120		112	107		121	2668		206	2647	1192
v/s Ratio Prot		0.01			0.00			0.42			c0.52	
v/s Ratio Perm	c0.02			0.01			0.28			0.11		0.04
v/c Ratio	0.32	0.13		0.09	0.06		0.37	0.56		0.15	0.70	0.06
Uniform Delay, d1	29.4	29.0		28.9	28.8		3.0	3.7		2.4	4.5	2.2
Progression Factor	1.00	1.00		1.00	1.00		1.00	1.00		1.00	1.00	1.00
Incremental Delay, d2	1.7	0.5		0.3	0.2		8.5	0.8		1.5	1.5	0.1
Delay (s)	31.1	29.5		29.2	29.0		11.5	4.5		3.9	6.0	2.3
Level of Service	C	C		C	C		B	A		A	A	A
Approach Delay (s)		30.4			29.1			4.7			5.8	
Approach LOS		C			C			A			A	
Intersection Summary												
HCM 2000 Control Delay	6.0		HCM 2000 Level of Service				A					
HCM 2000 Volume to Capacity ratio	0.66											
Actuated Cycle Length (s)	66.8		Sum of lost time (s)				12.0					
Intersection Capacity Utilization	69.5%		ICU Level of Service				C					
Analysis Period (min)	15											
c Critical Lane Group												

HCM Unsignalized Intersection Capacity Analysis
 3: Hillpath Cres/McAlpine Rd & Highwood Rd

Future Background PM (2032)
 Argo Summer Valley (7597-06)

Movement	EBL	EBT	EBR	WBL	WBT	WBR	NBL	NBT	NBR	SBL	SBT	SBR
Lane Configurations		↔			↔			↔			↔	
Traffic Volume (veh/h)	0	40	15	0	30	0	5	0	0	0	0	0
Future Volume (Veh/h)	0	40	15	0	30	0	5	0	0	0	0	0
Sign Control	Free		Free		Stop		Stop		Stop			
Grade	0%		0%		0%		0%		0%			
Peak Hour Factor	1.00	1.00	1.00	1.00	1.00	1.00	1.00	1.00	1.00	1.00	1.00	1.00
Hourly flow rate (vph)	0	40	15	0	30	0	5	0	0	0	0	0
Pedestrians												
Lane Width (m)												
Walking Speed (m/s)												
Percent Blockage												
Right turn flare (veh)												
Median type	None		None									
Median storage (veh)												
Upstream signal (m)	84											
pX, platoon unblocked												
vC, conflicting volume	30			55			78	78	48	78	85	30
vC1, stage 1 conf vol												
vC2, stage 2 conf vol												
vCu, unblocked vol	30			55			78	78	48	78	85	30
tC, single (s)	4.1			4.1			7.2	6.5	6.2	7.1	6.5	6.2
tC, 2 stage (s)												
tF (s)	2.2			2.2			3.6	4.0	3.3	3.5	4.0	3.3
p0 queue free %	100			100			99	100	100	100	100	100
cM capacity (veh/h)	1596			1563			883	817	1027	916	809	1050
Direction, Lane #	EB 1	WB 1	NB 1	SB 1								
Volume Total	55	30	5	0								
Volume Left	0	0	5	0								
Volume Right	15	0	0	0								
cSH	1596	1563	883	1700								
Volume to Capacity	0.00	0.00	0.01	0.00								
Queue Length 95th (m)	0.0	0.0	0.1	0.0								
Control Delay (s)	0.0	0.0	9.1	0.0								
Lane LOS	A				A							
Approach Delay (s)	0.0	0.0	9.1	0.0								
Approach LOS	A				A							
Intersection Summary												
Average Delay	0.5											
Intersection Capacity Utilization	13.3%		ICU Level of Service				A					
Analysis Period (min)	15											

Timings

2: Hurontario St & Collingwood Ave/Highwood Rd

Future Total AM (2032)

Argo Summer Valley (7597-06)

	↖	→	↗	←	↖	↑	↗	↓	↖	
Lane Group	EBL	EBT	WBL	WBT	NBL	NBT	SBL	SBT	SBR	
Lane Configurations	↖	↗	↖	↗	↖	↗	↖	↗	↖	
Traffic Volume (vph)	50	25	32	5	20	988	68	1532	25	
Future Volume (vph)	50	25	32	5	20	988	68	1532	25	
Turn Type	Perm	NA	Perm	NA	Perm	NA	Perm	NA	Perm	
Protected Phases	4		8		2		6		6	
Permitted Phases	4	8		2		6		6		
Detector Phase	4	4	8	8	2	2	6	6	6	
Switch Phase										
Minimum Initial (s)	5.0	5.0	5.0	5.0	5.0	5.0	5.0	5.0	5.0	
Minimum Split (s)	24.0	24.0	24.0	24.0	26.0	26.0	26.0	26.0	26.0	
Total Split (s)	24.0	24.0	24.0	24.0	48.0	48.0	48.0	48.0	48.0	
Total Split (%)	33.3%	33.3%	33.3%	33.3%	66.7%	66.7%	66.7%	66.7%	66.7%	
Maximum Green (s)	18.0	18.0	18.0	18.0	42.0	42.0	42.0	42.0	42.0	
Yellow Time (s)	4.0	4.0	4.0	4.0	4.0	4.0	4.0	4.0	4.0	
All-Red Time (s)	2.0	2.0	2.0	2.0	2.0	2.0	2.0	2.0	2.0	
Lost Time Adjust (s)	0.0	0.0	0.0	0.0	0.0	0.0	0.0	0.0	0.0	
Total Lost Time (s)	6.0	6.0	6.0	6.0	6.0	6.0	6.0	6.0	6.0	
Lead/Lag										
Lead-Lag Optimize?										
Vehicle Extension (s)	3.0	3.0	3.0	3.0	3.0	3.0	3.0	3.0	3.0	
Minimum Gap (s)	3.0	3.0	3.0	3.0	3.0	3.0	3.0	3.0	3.0	
Time Before Reduce (s)	0.0	0.0	0.0	0.0	0.0	0.0	0.0	0.0	0.0	
Time To Reduce (s)	0.0	0.0	0.0	0.0	0.0	0.0	0.0	0.0	0.0	
Recall Mode	None	None	None	None	Max	Max	Max	Max	Max	
Walk Time (s)	8.0	8.0	8.0	8.0	8.0	8.0	8.0	8.0	8.0	
Flash Dont Walk (s)	10.0	10.0	10.0	10.0	12.0	12.0	12.0	12.0	12.0	
Pedestrian Calls (#/hr)	0	0	0	0	0	0	0	0	0	

Intersection Summary

Cycle Length: 72

Actuated Cycle Length: 64.6

Natural Cycle: 60

Control Type: Semi Act-Uncoord

Splits and Phases: 2: Hurontario St & Collingwood Ave/Highwood Rd

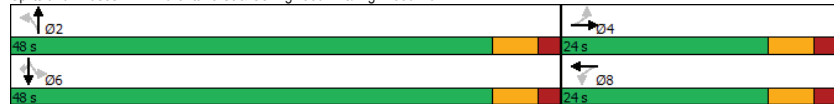

Queues

2: Hurontario St & Collingwood Ave/Highwood Rd

Future Total AM (2032)

Argo Summer Valley (7597-06)

	↖	→	↗	←	↖	↑	↗	↓	↖
Lane Group	EBL	EBT	WBL	WBT	NBL	NBT	SBL	SBT	SBR
Lane Group Flow (vph)	50	55	32	66	20	1014	68	1532	25
v/c Ratio	0.32	0.24	0.20	0.26	0.11	0.40	0.18	0.61	0.02
Control Delay	30.5	16.6	27.1	11.1	6.0	4.9	5.7	6.9	0.8
Queue Delay	0.0	0.0	0.0	0.0	0.0	0.0	0.0	0.5	0.0
Total Delay	30.5	16.6	27.1	11.1	6.0	4.9	5.7	7.5	0.8
Queue Length 50th (m)	5.3	2.6	3.3	0.5	0.7	22.1	2.3	43.1	0.0
Queue Length 95th (m)	13.7	10.9	10.0	9.4	3.5	38.3	7.9	74.4	1.2
Internal Link Dist (m)	343.0		60.2		420.4		84.7		
Turn Bay Length (m)					19.8		48.8		38.1
Base Capacity (vph)	346	483	356	488	178	2509	375	2516	1200
Starvation Cap Reductn	0	0	0	0	0	0	0	511	0
Spillback Cap Reductn	0	0	0	0	0	0	0	0	0
Storage Cap Reductn	0	0	0	0	0	0	0	0	0
Reduced v/c Ratio	0.14	0.11	0.09	0.14	0.11	0.40	0.18	0.76	0.02

Intersection Summary

HCM Signalized Intersection Capacity Analysis
 2: Hurontario St & Collingwood Ave/Highwood Rd

Future Total AM (2032)
 Argo Summer Valley (7597-06)

Movement	EBL	EBT	EBR	WBL	WBT	WBR	NBL	NBT	NBR	SBL	SBT	SBR
Lane Configurations	↔	↔		↔	↔		↔	↔		↔	↔	↔
Traffic Volume (vph)	50	25	30	32	5	61	20	988	26	68	1532	25
Future Volume (vph)	50	25	30	32	5	61	20	988	26	68	1532	25
Ideal Flow (vphpl)	1900	1900	1900	1900	1900	1900	1900	1900	1900	1900	1900	1900
Lane Width	3.5	3.7	3.5	3.5	3.7	3.5	3.5	3.7	3.5	3.5	3.7	3.5
Total Lost time (s)	6.0	6.0		6.0	6.0		6.0	6.0		6.0	6.0	6.0
Lane Util. Factor	1.00	1.00		1.00	1.00		1.00	0.95		1.00	0.95	1.00
Frt	1.00	0.92		1.00	0.86		1.00	1.00		1.00	1.00	0.85
Fit Protected	0.95	1.00		0.95	1.00		0.95	1.00		0.95	1.00	1.00
Satd. Flow (prot)	1653	1657		1684	1596		1700	3369		1767	3380	1597
Fit Permitted	0.71	1.00		0.72	1.00		0.13	1.00		0.27	1.00	1.00
Satd. Flow (perm)	1242	1657		1278	1596		240	3369		503	3380	1597
Peak-hour factor, PHF	1.00	1.00	1.00	1.00	1.00	1.00	1.00	1.00	1.00	1.00	1.00	1.00
Adj. Flow (vph)	50	25	30	32	5	61	20	988	26	68	1532	25
RTOR Reduction (vph)	0	27	0	0	55	0	0	2	0	0	0	7
Lane Group Flow (vph)	50	28	0	32	11	0	20	1012	0	68	1532	18
Heavy Vehicles (%)	8%	7%	6%	6%	0%	4%	5%	8%	5%	1%	8%	0%
Turn Type	Perm	NA		Perm	NA		Perm	NA		Perm	NA	Perm
Protected Phases		4			8			2			6	
Permitted Phases	4			8			2			6		6
Actuated Green, G (s)	7.0	7.0		7.0	7.0		46.9	46.9		46.9	46.9	46.9
Effective Green, g (s)	7.0	7.0		7.0	7.0		46.9	46.9		46.9	46.9	46.9
Actuated g/C Ratio	0.11	0.11		0.11	0.11		0.71	0.71		0.71	0.71	0.71
Clearance Time (s)	6.0	6.0		6.0	6.0		6.0	6.0		6.0	6.0	6.0
Vehicle Extension (s)	3.0	3.0		3.0	3.0		3.0	3.0		3.0	3.0	3.0
Lane Grp Cap (vph)	131	176		135	169		170	2397		357	2405	1136
v/s Ratio Prot		0.02			0.01			0.30			c0.45	
v/s Ratio Perm	c0.04			0.03			0.08			0.14		0.01
v/c Ratio	0.38	0.16		0.24	0.07		0.12	0.42		0.19	0.64	0.02
Uniform Delay, d1	27.4	26.8		27.0	26.5		3.0	3.9		3.2	5.0	2.8
Progression Factor	1.00	1.00		1.00	1.00		1.00	1.00		1.00	1.00	1.00
Incremental Delay, d2	1.9	0.4		0.9	0.2		1.4	0.5		1.2	1.3	0.0
Delay (s)	29.3	27.2		27.9	26.7		4.4	4.5		4.4	6.3	2.8
Level of Service	C	C		C	C		A	A		A	A	A
Approach Delay (s)		28.2			27.1			4.5			6.2	
Approach LOS		C			C			A			A	
Intersection Summary												
HCM 2000 Control Delay		7.1										A
HCM 2000 Volume to Capacity ratio		0.60										
Actuated Cycle Length (s)		65.9						Sum of lost time (s)		12.0		
Intersection Capacity Utilization		71.0%										C
Analysis Period (min)		15										

HCM Unsignalized Intersection Capacity Analysis
 3: Hillpath Cres/McAlpine Rd & Highwood Rd

Future Total AM (2032)
 Argo Summer Valley (7597-06)

Movement	EBL	EBT	EBR	WBL	WBT	WBR	NBL	NBT	NBR	SBL	SBT	SBR
Lane Configurations		↔			↔			↔			↔	
Traffic Volume (veh/h)	14	100	5	0	55	0	10	0	0	0	0	33
Future Volume (Veh/h)	14	100	5	0	55	0	10	0	0	0	0	33
Sign Control		Free			Free			Stop			Stop	
Grade		0%			0%			0%			0%	
Peak Hour Factor	1.00	1.00	1.00	1.00	1.00	1.00	1.00	1.00	1.00	1.00	1.00	1.00
Hourly flow rate (vph)	14	100	5	0	55	0	10	0	0	0	0	33
Pedestrians												
Lane Width (m)												
Walking Speed (m/s)												
Percent Blockage												
Right turn flare (veh)												
Median type		None			None							
Median storage (veh)												
Upstream signal (m)		84										
pX, platoon unblocked												
vC, conflicting volume		55			105			218	186	102	186	188
vC1, stage 1 conf vol												55
vC2, stage 2 conf vol												
vCu, unblocked vol		55			105			218	186	102	186	188
tC, single (s)		4.1			4.1			7.1	6.5	6.2	7.1	6.5
tC, 2 stage (s)												6.2
tF (s)		2.2			2.2			3.5	4.0	3.3	3.5	4.0
p0 queue free %		99			100			99	100	100	100	97
cM capacity (veh/h)		1563			1499			713	706	958	774	704
Direction, Lane #	EB 1	WB 1	NB 1	SB 1								
Volume Total	119	55	10	33								
Volume Left	14	0	10	0								
Volume Right	5	0	0	33								
cSH	1563	1499	713	1018								
Volume to Capacity	0.01	0.00	0.01	0.03								
Queue Length 95th (m)	0.2	0.0	0.3	0.8								
Control Delay (s)	0.9	0.0	10.1	8.7								
Lane LOS	A		B	A								
Approach Delay (s)	0.9	0.0	10.1	8.7								
Approach LOS			B	A								
Intersection Summary												
Average Delay				2.3								
Intersection Capacity Utilization				26.9%				ICU Level of Service				A
Analysis Period (min)				15								

Timings

2: Hurontario St & Collingwood Ave/Highwood Rd

Future Total PM (2032)

Argo Summer Valley (7597-06)

	↖	→	↗	←	↖	↑	↗	↓	↖
Lane Group	EBL	EBT	WBL	WBT	NBL	NBT	SBL	SBT	SBR
Lane Configurations	↖	↖	↖	↖	↖	↖	↖	↖	↖
Traffic Volume (vph)	35	5	23	5	45	1464	50	1842	85
Future Volume (vph)	35	5	23	5	45	1464	50	1842	85
Turn Type	Perm	NA	Perm	NA	Perm	NA	Perm	NA	Perm
Protected Phases	4		8		2		6		6
Permitted Phases	4	8		2		6		6	6
Detector Phase	4	4	8	8	2	2	6	6	6
Switch Phase									
Minimum Initial (s)	5.0	5.0	5.0	5.0	5.0	5.0	5.0	5.0	5.0
Minimum Split (s)	24.0	24.0	24.0	24.0	26.0	26.0	26.0	26.0	26.0
Total Split (s)	24.0	24.0	24.0	24.0	48.0	48.0	48.0	48.0	48.0
Total Split (%)	33.3%	33.3%	33.3%	33.3%	66.7%	66.7%	66.7%	66.7%	66.7%
Maximum Green (s)	18.0	18.0	18.0	18.0	42.0	42.0	42.0	42.0	42.0
Yellow Time (s)	4.0	4.0	4.0	4.0	4.0	4.0	4.0	4.0	4.0
All-Red Time (s)	2.0	2.0	2.0	2.0	2.0	2.0	2.0	2.0	2.0
Lost Time Adjust (s)	0.0	0.0	0.0	0.0	0.0	0.0	0.0	0.0	0.0
Total Lost Time (s)	6.0	6.0	6.0	6.0	6.0	6.0	6.0	6.0	6.0
Lead/Lag									
Lead-Lag Optimize?									
Vehicle Extension (s)	3.0	3.0	3.0	3.0	3.0	3.0	3.0	3.0	3.0
Minimum Gap (s)	3.0	3.0	3.0	3.0	3.0	3.0	3.0	3.0	3.0
Time Before Reduce (s)	0.0	0.0	0.0	0.0	0.0	0.0	0.0	0.0	0.0
Time To Reduce (s)	0.0	0.0	0.0	0.0	0.0	0.0	0.0	0.0	0.0
Recall Mode	None	None	None	None	Max	Max	Max	Max	Max
Walk Time (s)	8.0	8.0	8.0	8.0	8.0	8.0	8.0	8.0	8.0
Flash Dont Walk (s)	10.0	10.0	10.0	10.0	12.0	12.0	12.0	12.0	12.0
Pedestrian Calls (#/hr)	0	0	0	0	0	0	0	0	0

Intersection Summary

Cycle Length: 72

Actuated Cycle Length: 63.4

Natural Cycle: 65

Control Type: Semi Act-Uncoord

Splits and Phases: 2: Hurontario St & Collingwood Ave/Highwood Rd

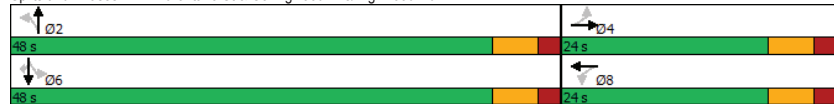

Queues

2: Hurontario St & Collingwood Ave/Highwood Rd

Future Total PM (2032)

Argo Summer Valley (7597-06)

	↖	→	↗	←	↖	↑	↗	↓	↖
Lane Group	EBL	EBT	WBL	WBT	NBL	NBT	SBL	SBT	SBR
Lane Group Flow (vph)	35	30	23	36	45	1502	50	1842	85
v/c Ratio	0.21	0.15	0.13	0.19	0.34	0.52	0.23	0.64	0.07
Control Delay	27.7	18.4	26.1	13.7	14.9	4.9	7.3	6.4	1.7
Queue Delay	0.0	0.0	0.0	0.0	0.0	0.0	0.0	0.6	0.0
Total Delay	27.7	18.4	26.1	13.7	14.9	4.9	7.3	6.9	1.7
Queue Length 50th (m)	4.0	1.7	2.6	0.6	1.7	37.6	1.7	56.0	0.6
Queue Length 95th (m)	10.5	7.8	7.9	7.2	#15.5	61.4	7.6	92.9	4.1
Internal Link Dist (m)	343.0		60.2		420.4		84.7		
Turn Bay Length (m)					19.8		48.8		38.1
Base Capacity (vph)	418	476	435	441	131	2887	217	2868	1304
Starvation Cap Reductn	0	0	0	0	0	0	0	550	0
Spillback Cap Reductn	0	0	0	0	0	0	0	0	0
Storage Cap Reductn	0	0	0	0	0	0	0	0	0
Reduced v/c Ratio	0.08	0.06	0.05	0.08	0.34	0.52	0.23	0.79	0.07

Intersection Summary

95th percentile volume exceeds capacity, queue may be longer.

Queue shown is maximum after two cycles.

HCM Signalized Intersection Capacity Analysis
 2: Hurontario St & Collingwood Ave/Highwood Rd

Future Total PM (2032)
 Argo Summer Valley (7597-06)

Movement	EBL	EBT	EBR	WBL	WBT	WBR	NBL	NBT	NBR	SBL	SBT	SBR
Lane Configurations	↔	↔	↔	↔	↔	↔	↔	↔	↔	↔	↔	↔
Traffic Volume (vph)	35	5	25	23	5	31	45	1464	38	50	1842	85
Future Volume (vph)	35	5	25	23	5	31	45	1464	38	50	1842	85
Ideal Flow (vphpl)	1900	1900	1900	1900	1900	1900	1900	1900	1900	1900	1900	1900
Lane Width	3.5	3.7	3.5	3.5	3.7	3.5	3.5	3.7	3.5	3.5	3.7	3.5
Total Lost time (s)	6.0	6.0		6.0	6.0		6.0	6.0		6.0	6.0	6.0
Lane Util. Factor	1.00	1.00		1.00	1.00		1.00	0.95		1.00	0.95	1.00
Frt	1.00	0.88		1.00	0.87		1.00	1.00		1.00	1.00	0.85
Fit Protected	0.95	1.00		0.95	1.00		0.95	1.00		0.95	1.00	1.00
Satd. Flow (prot)	1715	1640		1785	1477		1750	3567		1733	3544	1597
Fit Permitted	0.82	1.00		0.82	1.00		0.09	1.00		0.15	1.00	1.00
Satd. Flow (perm)	1474	1640		1534	1477		162	3567		269	3544	1597
Peak-hour factor, PHF	1.00	1.00	1.00	1.00	1.00	1.00	1.00	1.00	1.00	1.00	1.00	1.00
Adj. Flow (vph)	35	5	25	23	5	31	45	1464	38	50	1842	85
RTOR Reduction (vph)	0	14	0	0	29	0	2	0	0	0	0	16
Lane Group Flow (vph)	35	16	0	23	7	0	45	1500	0	50	1842	69
Heavy Vehicles (%)	2%	0%	3%	0%	40%	9%	2%	2%	0%	3%	3%	0%
Bus Blockages (#/hr)	5	0	0	0	0	0	0	0	0	0	0	0
Turn Type	Perm	NA		Perm	NA		Perm	NA		Perm	NA	Perm
Protected Phases		4			8			2			6	
Permitted Phases	4			8			2			6		6
Actuated Green, G (s)	4.9	4.9		4.9	4.9		48.9	48.9		48.9	48.9	48.9
Effective Green, g (s)	4.9	4.9		4.9	4.9		48.9	48.9		48.9	48.9	48.9
Actuated g/C Ratio	0.07	0.07		0.07	0.07		0.74	0.74		0.74	0.74	0.74
Clearance Time (s)	6.0	6.0		6.0	6.0		6.0	6.0		6.0	6.0	6.0
Vehicle Extension (s)	3.0	3.0		3.0	3.0		3.0	3.0		3.0	3.0	3.0
Lane Grp Cap (vph)	109	122		114	109		120	2650		199	2633	1186
v/s Ratio Prot		0.01			0.00			0.42			c0.52	
v/s Ratio Perm	c0.02			0.01			0.28			0.19		0.04
v/c Ratio	0.32	0.13		0.20	0.07		0.38	0.57		0.25	0.70	0.06
Uniform Delay, d1	28.9	28.5		28.6	28.3		3.0	3.7		2.7	4.5	2.3
Progression Factor	1.00	1.00		1.00	1.00		1.00	1.00		1.00	1.00	1.00
Incremental Delay, d2	1.7	0.5		0.9	0.3		8.7	0.9		3.0	1.6	0.1
Delay (s)	30.6	29.0		29.5	28.6		11.7	4.6		5.7	6.1	2.4
Level of Service	C	C		C	C		B	A		A	A	A
Approach Delay (s)		29.8			28.9			4.8			5.9	
Approach LOS		C			C			A			A	
Intersection Summary												
HCM 2000 Control Delay	6.3		HCM 2000 Level of Service				A					
HCM 2000 Volume to Capacity ratio	0.66											
Actuated Cycle Length (s)	65.8		Sum of lost time (s)				12.0					
Intersection Capacity Utilization	69.5%		ICU Level of Service				C					
Analysis Period (min)	15											
c Critical Lane Group												

HCM Unsignalized Intersection Capacity Analysis
 3: Hillpath Cres/McAlpine Rd & Highwood Rd

Future Total PM (2032)
 Argo Summer Valley (7597-06)

Movement	EBL	EBT	EBR	WBL	WBT	WBR	NBL	NBT	NBR	SBL	SBT	SBR
Lane Configurations		↔			↔			↔			↔	
Traffic Volume (veh/h)	38	40	15	0	30	0	5	0	0	0	0	24
Future Volume (Veh/h)	38	40	15	0	30	0	5	0	0	0	0	24
Sign Control	Free		Free		Stop		Stop		Stop			
Grade	0%		0%		0%		0%		0%			
Peak Hour Factor	1.00	1.00	1.00	1.00	1.00	1.00	1.00	1.00	1.00	1.00	1.00	1.00
Hourly flow rate (vph)	38	40	15	0	30	0	5	0	0	0	0	24
Pedestrians												
Lane Width (m)												
Walking Speed (m/s)												
Percent Blockage												
Right turn flare (veh)												
Median type	None		None									
Median storage (veh)												
Upstream signal (m)	84											
pX, platoon unblocked												
vC, conflicting volume	30			55			178	154	48	154	161	30
vC1, stage 1 conf vol												
vC2, stage 2 conf vol												
vCu, unblocked vol	30			55			178	154	48	154	161	30
tC, single (s)	4.1			4.1			7.2	6.5	6.2	7.1	6.5	6.2
tC, 2 stage (s)												
tF (s)	2.2			2.2			3.6	4.0	3.3	3.5	4.0	3.3
p0 queue free %	98			100			99	100	100	100	100	98
cM capacity (veh/h)	1596			1563			728	724	1027	803	717	1050
Direction, Lane #												
	EB 1	WB 1	NB 1	SB 1								
Volume Total	93	30	5	24								
Volume Left	38	0	5	0								
Volume Right	15	0	0	24								
cSH	1596	1563	728	1050								
Volume to Capacity	0.02	0.00	0.01	0.02								
Queue Length 95th (m)	0.6	0.0	0.2	0.5								
Control Delay (s)	3.1	0.0	10.0	8.5								
Lane LOS	A		A	A								
Approach Delay (s)	3.1	0.0	10.0	8.5								
Approach LOS			A	A								
Intersection Summary												
Average Delay	3.6											
Intersection Capacity Utilization	22.6%		ICU Level of Service				A					
Analysis Period (min)	15											

Appendix K
SimTraffic Worksheets

Queuing and Blocking Report
Future Total AM (2027)

Future Total AM (2027)
Argo Summer Valley (7597-06)

Intersection: 2: Hurontario St & Collingwood Ave/Highwood Rd

Movement	EB	EB	WB	WB	NB	NB	NB	SB	SB	SB	SB	
Directions Served	L	TR	L	TR	L	T	TR	L	T	T	R	
Maximum Queue (m)	33.4	41.7	21.0	27.0	26.9	41.4	26.0	25.3	52.0	39.1	6.4	
Average Queue (m)	11.7	10.0	9.0	10.5	3.1	15.7	10.3	10.9	26.4	13.7	2.0	
95th Queue (m)	22.1	24.8	19.0	18.0	12.1	30.5	23.2	20.7	43.1	30.4	6.3	
Link Distance (m)	350.1	350.1	60.2	60.2		432.0	432.0		97.1	97.1		
Upstream Blk Time (%)												
Queuing Penalty (veh)												
Storage Bay Dist (m)					19.8		48.8		38.1			
Storage Blk Time (%)					3		0		0			
Queuing Penalty (veh)					1		0		0			

Intersection: 3: Hillpath Cres/McAlpine Rd & Highwood Rd

Movement	EB	NB	SB
Directions Served	LTR	LTR	LTR
Maximum Queue (m)	15.4	9.3	8.5
Average Queue (m)	0.8	3.3	6.6
95th Queue (m)	5.9	10.5	12.1
Link Distance (m)	60.2	124.8	90.8
Upstream Blk Time (%)			
Queuing Penalty (veh)			
Storage Bay Dist (m)			
Storage Blk Time (%)			
Queuing Penalty (veh)			

Network Summary

Network wide Queuing Penalty: 1

Queuing and Blocking Report
Future Total PM (2027)

Future Total PM (2027)
Argo Summer Valley (7597-06)

Intersection: 2: Hurontario St & Collingwood Ave/Highwood Rd

Movement	EB	EB	WB	WB	NB	NB	NB	SB	SB	SB	SB	
Directions Served	L	TR	L	TR	L	T	TR	L	T	T	R	
Maximum Queue (m)	15.0	15.4	20.1	23.6	14.2	25.4	33.6	14.8	50.0	36.9	12.7	
Average Queue (m)	4.8	5.3	5.2	6.9	4.8	13.1	9.4	7.1	23.6	11.6	2.6	
95th Queue (m)	12.6	12.2	15.2	17.1	11.3	24.5	21.5	13.9	41.2	25.6	8.0	
Link Distance (m)	350.1	350.1	60.2	60.2		432.0	432.0		97.1	97.1		
Upstream Blk Time (%)												
Queuing Penalty (veh)												
Storage Bay Dist (m)					19.8		48.8		38.1			
Storage Blk Time (%)					0		1		0			
Queuing Penalty (veh)					0		1		0			

Intersection: 3: Hillpath Cres/McAlpine Rd & Highwood Rd

Movement	EB	NB	SB
Directions Served	LTR	LTR	LTR
Maximum Queue (m)	9.0	9.2	8.5
Average Queue (m)	0.6	2.4	3.9
95th Queue (m)	4.2	8.9	10.7
Link Distance (m)	60.2	124.8	95.6
Upstream Blk Time (%)			
Queuing Penalty (veh)			
Storage Bay Dist (m)			
Storage Blk Time (%)			
Queuing Penalty (veh)			

Network Summary

Network wide Queuing Penalty: 1

Queuing and Blocking Report
Future Total AM (2032)

Future Total AM (2032)
Argo Summer Valley (7597-06)

Intersection: 2: Hurontario St & Collingwood Ave/Highwood Rd

Movement	EB	EB	WB	WB	NB	NB	NB	SB	SB	SB	SB	
Directions Served	L	TR	L	TR	L	T	TR	L	T	T	R	
Maximum Queue (m)	32.6	19.4	20.7	21.9	19.5	39.7	45.4	56.1	78.7	61.8	6.3	
Average Queue (m)	11.0	8.4	8.5	10.1	4.6	19.5	15.6	9.5	38.1	28.3	1.5	
95th Queue (m)	26.8	17.6	18.6	17.3	13.4	33.7	33.7	31.3	61.2	54.2	5.5	
Link Distance (m)	350.1	350.1	60.2	60.2		432.0	432.0		97.1	97.1		
Upstream Blk Time (%)												
Queuing Penalty (veh)												
Storage Bay Dist (m)					19.8		48.8		38.1			
Storage Blk Time (%)					2		5		0		2	
Queuing Penalty (veh)					8		1		0		1	

Intersection: 3: Hillpath Cres/McAlpine Rd & Highwood Rd

Movement	EB	NB	SB
Directions Served	LTR	LTR	LTR
Maximum Queue (m)	9.2	9.3	8.5
Average Queue (m)	0.3	2.4	5.8
95th Queue (m)	3.0	8.9	12.1
Link Distance (m)	60.2	124.8	90.8
Upstream Blk Time (%)			
Queuing Penalty (veh)			
Storage Bay Dist (m)			
Storage Blk Time (%)			
Queuing Penalty (veh)			

Network Summary

Network wide Queuing Penalty: 10

Queuing and Blocking Report
Future Total PM (2032)

Future Total PM (2032)
Argo Summer Valley (7597-06)

Intersection: 2: Hurontario St & Collingwood Ave/Highwood Rd

Movement	EB	EB	WB	WB	NB	NB	NB	SB	SB	SB	SB	
Directions Served	L	TR	L	TR	L	T	TR	L	T	T	R	
Maximum Queue (m)	20.2	29.0	15.0	29.2	27.2	126.8	126.3	21.7	87.5	78.8	45.7	
Average Queue (m)	7.2	7.7	6.4	8.4	12.3	36.0	32.4	9.5	46.9	34.3	6.7	
95th Queue (m)	15.4	21.5	14.7	20.9	26.3	80.7	71.8	19.2	78.2	67.6	28.7	
Link Distance (m)	350.1	350.1	60.2	60.2		432.0	432.0		97.1	97.1		
Upstream Blk Time (%)												
Queuing Penalty (veh)												
Storage Bay Dist (m)					19.8		48.8		38.1			
Storage Blk Time (%)					14		9		4		3	
Queuing Penalty (veh)					104		4		2		2	

Intersection: 3: Hillpath Cres/McAlpine Rd & Highwood Rd

Movement	NB	SB
Directions Served	LTR	LTR
Maximum Queue (m)	20.6	8.5
Average Queue (m)	1.5	4.1
95th Queue (m)	9.5	11.0
Link Distance (m)	124.8	95.6
Upstream Blk Time (%)		
Queuing Penalty (veh)		
Storage Bay Dist (m)		
Storage Blk Time (%)		
Queuing Penalty (veh)		

Network Summary

Network wide Queuing Penalty: 113