

**REGION OF PEEL CONSTRUCTION NOTES:**

**1.0 GENERAL**

- 1.1 THE APPLICANT, APPLICANT'S REPRESENTATIVE, CONSULTANT, CONTRACTOR AND SUB CONTRACTORS ARE RESPONSIBLE TO ENSURE THAT THEIR DESIGN MATERIALS AND CONSTRUCTION PRACTICES CONFORM TO THE LATEST REGION OF PEEL STANDARDS, SPECIFICATIONS, MATERIALS, AND DESIGN CRITERIA, POSTED ON REGION OF PEEL'S WEBSITE ([www.peelregion.ca/planning/roads](http://www.peelregion.ca/planning/roads)), IN THE ABSENCE OF REGION SPECIFICATIONS, THE ONTARIO PROVINCIAL STANDARD SPECIFICATIONS (OPSS) SHALL APPLY.
- 1.2 ALL WORKS SHALL BE COMPLETED IN ACCORDANCE WITH THE "OCCUPATIONAL HEALTH AND SAFETY ACT". THE GENERAL CONTRACTOR SHALL BE DEEMED THE CONSTRUCTOR AS DEFINED IN THE ACT. THE CONTRACTOR SHALL, AT THEIR EXPENSE, VERIFY THE LOCATION, DIMENSION, AND ELEVATION OF ALL EXISTING SERVICES AND UTILITIES IN THE FIELD. PRIOR TO EXCAVATION OR BORING, THE CONTRACTOR SHALL, AT THEIR EXPENSE, EXPOSE AND VERIFY THE LOCATION, DIMENSION, AND ELEVATION OF ALL EXISTING UTILITIES AND SERVICES TO BE CROSSED, AND MUST NOTIFY THE DESIGN ENGINEER AND THE AGENCY FIELD INSPECTOR AND/OR PROJECT MANAGER IMMEDIATELY, IN WRITING, OF ANY CONFLICTS OR DISCREPANCIES. THE CONTRACTOR SHALL BE RESPONSIBLE FOR EXPOSING THE EXISTING UTILITIES FAR ENOUGH IN ADVANCE OF CONSTRUCTION TO MAKE NECESSARY DESIGN MODIFICATIONS FOR REVIEW AND APPROVAL, IF REQUIRED, WITHOUT DELAYING THE WORK.
- 1.3 THE CONTRACTOR SHALL, AT THEIR EXPENSE AND TO THE SATISFACTION OF THE REGION OF PEEL, BE RESPONSIBLE FOR THE RESTORATION AND THE REPAIR OF THE EXISTING UTILITIES AND ALL AREAS BEYOND THE PLAN OF SUBDIVISION DISTURBED DURING CONSTRUCTION.
- 1.4 THE SUPPORT OF ALL UTILITIES SHALL BE IN ACCORDANCE WITH THE REQUIREMENTS OF THE AUTHORITY HAVING JURISDICTION.
- 1.5 ALL BACKFILL FOR SEWERS, WATERMANS, AND UTILITIES ON THE ROAD ALLOWANCE MUST BE MECHANICALLY COMPACTED.
- 1.6 ALL BOREHOLES SHOWN ON DRAWING ARE FOR INFORMATION ONLY. REFER TO GEOTECHNICAL REPORT.
- 1.7 ALL DIMENSIONS ARE IN METRES UNLESS OTHERWISE SPECIFIED.

**2.0 WATERMAIN (IN CUT)**

- 2.1 THE REGION OF PEEL SHALL CONDUCT THE OPERATION OF EXISTING VALVES AND HYDRANTS IF REQUIRED.
- 2.2 ALL WATERMANS SHALL HAVE 1.7m MINIMUM COVER FOR URBAN ROAD DESIGN AND 2.1m MINIMUM COVER FOR RURAL ROAD DESIGN.
- 2.3 ALL WATERMANS SHALL MAINTAIN A MINIMUM 1.5m CLEARANCE FROM ALL MANHOLES AND CATCH BASINS, WHERE APPLICABLE.
- 2.4 FOR WATERMANS CROSSING OVER OR UNDER SEWERS, A MINIMUM 0.5m VERTICAL CLEARANCE SHALL BE PROVIDED.
- 2.5 FOR WATERMAIN CROSSING A SANITARY SEWER, WATERMAIN JOINTS ARE TO BE OFFSET A MINIMUM OF 2.5m HORIZONTALLY FROM THE CENTERLINE OF THE SANITARY SEWER.
- 2.6 WATERMAIN BEDDING SHOULD BE AS PER TRENCH DETAIL ON THE PLAN AND PROFILE DRAWING AND COMPACTED TO 100% SPD.
- 2.7 WATERMANS TO BE INSTALLED TO GRADES AS SHOWN ON APPROVED PLANS. A COPY OF THE GRADE SHEET MUST BE SUPPLIED TO THE REGION OF PEEL INSPECTOR PRIOR TO COMMENCEMENT OF WORK.
- 2.8 ANY JOINT DEFLECTION SHALL NOT EXCEED 50% OF MANUFACTURER'S SPECIFICATIONS. PIPE BARREL DEFLECTION IS PROHIBITED.
- 2.9 FIRE HYDRANTS SHALL BE INSTALLED AS PER REGION STD. DWG. 1-6-1 OR 1-6-2 WITH FLANGE SET BETWEEN 50mm AND 150mm ABOVE FINISHED GRADE.
- 2.10 ALL HYDRANTS SHALL HAVE 1.2m MINIMUM HORIZONTAL CLEARANCE FROM ALL OTHER UTILITIES AND STRUCTURES MEASURED FROM THE NEAREST POINT OF THE STRUCTURE.
- 2.11 MECHANICAL RESTRAINTS ARE REQUIRED FOR ALL FITTINGS, VALVES, DEAD ENDS, CAPS, AND HYDRANTS ON ALL PVC WATERMANS; MINIMUM RESTRAINED PIPE LENGTH AS PER REGION'S STANDARD.
- 2.12 STAINLESS STEEL NUTS AND BOLTS ARE TO BE USED ON ALL METALLIC FITTINGS AND JOINT RESTRAINTS.
- 2.13 ALL METALLIC VALVES, FITTINGS, THROUGH WALL METAL PIPING, AND JOINT RESTRAINTS TO BE C/W DENSO PASTE, DENSO MASTIC & DENSO TAPE, OR APPROVED EQUAL, AND APPLIED TO THE MANUFACTURER'S RECOMMENDATIONS.
- 2.14 WHERE PLASTIC PIPE IS USED, INSTALL A 12 GAUGE TWJ STRANDED COPPER, LIGHT COLOURED, PLASTIC COATED TRACER WIRE ATTACHED TO THE PIPE WITH APPROVED WIRE SPLICE. THE WIRE SHOULD BE BROUGHT TO THE SURFACE AT EACH SERVICE, VALVE BOX, AND HYDRANT VALVE.
- 2.15 ALL 50mmØ WATERMAIN SHALL BE TYPE 'K' SOFT COPPER. WATERMAIN INSTALLATION IN CUL-DE-SACS AS PER REGION STD. DWG. 1-7-4.
- 2.16 A PHYSICAL SEPARATION MUST BE MAINTAINED AT ALL CONNECTION POINTS OF NEW WATERMAIN TO THE EXISTING SYSTEM UNTIL BACTERIOLOGICAL TESTS HAVE PASSED, AS PER STD. DWG 1-7-7 AND 1-7-8.
- 2.17 PROVISION FOR FLUSHING OF NEW WATERMANS PRIOR TO TESTING MUST BE PROVIDED WITH AT LEAST 50mm OUTLET ON WATERMANS SMALLER THAN 300mmØ, AND MINIMUM 100mm OUTLET ON WATERMANS 300mmØ AND LARGER. COPPER WATERMANS ARE TO HAVE FLUSHING POINTS AT THE END, THE SAME SIZE AS THE WATERMAIN, AS PER STD. DWG. 1-7-7 AND 1-7-8.
- 2.18 ALL SERVICE CONNECTIONS TO PVC PIPES ARE TO BE MADE USING APPROVED WIDE BAND SERVICE SADDLE. DIRECT TAPPING IS NOT ALLOWED.
- 2.19 ALL WATER SERVICES SHALL BE MINIMUM 25mmØ NOMINAL COPPER PIPE SIZE OR 32mmØ POLYETHYLENE PIPE. IN GENERAL, NON METALLIC SERVICES SHALL BE ONE SIZE LARGER THAN THE NOMINAL COPPER PIPE SIZE AS PER LATEST APPROVED REGIONAL PRODUCT LIST AND SIZES C/W TRACER WIRE.
- 2.20 THE MINIMUM LATERAL DISTANCE BETWEEN WATER SERVICES AND OTHER UTILITIES SHALL BE 1.2m.
- 2.21 ALL RESIDENTIAL WATER SERVICE BOXES/CURB STOPS SHALL BE INSTALLED WITHIN SODDED AREAS, WITH A MINIMUM DISTANCE OF 1.0m FROM THE EDGE OF THE DRIVEWAY, BE FLUSH WITH GRADE AND ACCESSIBLE AT ALL TIMES.
- 2.22 VALVE AND BOXES SHALL BE CAST IRON SLIDING TYPE, COMPLETED WITH VALVE GUIDE PLATES AND INSTALLED AS PER REGION STD. 1-3-8. MAINLINE VALVES TO BE RESTRAINED AS PER REGION STD. 1-3-3A. VALVES SHALL OPERATE TO THE LEFT (COUNTER-CLOCKWISE).
- 2.23 ALL WATER SERVICE BOXES SHOULD BE "LEAD FREE" AS PER REGION'S MATERIAL SPECIFICATIONS.
- 2.24 THE REGION WILL COMPLETE THE NECESSARY WATER TESTING (PRESSURE TEST, FLUSHING, CHLORINATION, AND SAMPLING). THE CONTRACTOR MAY PROCEED WITH THEIR OWN PRESSURE TEST AND FLUSHING PRIOR TO REGION'S TESTING.

**3.0 WATERMAIN (IN FILL)**

- 3.1 NO WATERMAIN TO BE LAID ON FILL UNTIL THE FIELD DENSITY TEST REPORTS HAVE BEEN SUBMITTED TO AND APPROVED BY THE REGION OF PEEL OR THE CONSULTING ENGINEER.
- 3.2 PIPE JOINT DEFLECTIONS ARE NOT ALLOWED IN FILL AREA.
- 3.3 JOINTS SHALL BE MECHANICALLY RESTRAINED THE WHOLE LENGTH.
- 3.4 ALL HYDRANTS, TEE BRANCH VALVES, AND HORIZONTAL BENDS ARE TO BE MECHANICALLY RESTRAINED WITH TIE RODS.
- 3.5 IN EXISTING MUNICIPAL RIGHT-OF-WAY OR EASEMENT, FILL TO BE PLACED TO 600mm MINIMUM ABOVE THE OVERT OF THE WATERMAIN AND TO 300mm EITHER SIDE, COMPACTED TO MINIMUM 100% STANDARD PROCTOR DENSITY IN 300mm LIFTS; AND THEREAFTER, FOR EVERY 300mm LIFT ALONG THE CENTERLINE, AND 1.5m TO EITHER SIDE, OF WATERMAIN AT MAXIMUM INTERVAL OF 30.0m. TEST RESULTS MUST BE SUBMITTED TO AND APPROVED BY THE CONSULTANT OR AGENCY.

**TOWN OF CALEDON NOTES:**

- a. CONSTRUCTION FOR THIS PROJECT TO COMPLY WITH THE MOST CURRENT VERSION OF THE DEVELOPMENT STANDARDS, POLICIES AND GUIDELINES, PREPARED BY THE TOWN OF CALEDON INFRASTRUCTURE DEPARTMENT AND THE ONTARIO PROVINCIAL STANDARDS AND SPECIFICATIONS.
- b. ALL PROPOSED CONSTRUCTION SHALL BE CARRIED OUT IN ACCORDANCE WITH THE REQUIREMENTS OF THE OCCUPATIONAL HEALTH AND SAFETY ACT AND REGULATIONS FOR CONSTRUCTION PROJECTS.
- c. A MINIMUM OF FORTY-EIGHT (48) HOURS PRIOR TO COMMENCING CONSTRUCTION WITHIN THE MUNICIPAL RIGHT OF WAY THE CONTRACTOR MUST CONTACT THE FOLLOWING:  
THE TOWN OF CALEDON  
PUBLIC WORKS AND  
ENGINEERING DEPARTMENT  
905-584-2272  
THE REGION OF PEEL ENBRIDGE CONSUMERS  
GAS HYDRO ONE BELL CANADA  
ROGERS CABLE FIRE AND EMERGENCY SERVICES
- d. ALL DRAINAGE TO BE SELF-CONTAINED AND DISCHARGED TO A LOCATION APPROVED BY THE PUBLIC WORKS AND ENGINEERING DEPARTMENT AND CONSERVATION AUTHORITY PRIOR TO THE ISSUANCE OF A BUILDING PERMIT.
- e. SEDIMENT CONTROL DEVICES ARE TO BE INSTALLED PRIOR TO ANY CONSTRUCTION ON THE SITE AND SHALL BE MAINTAINED THROUGHOUT THE CONSTRUCTION PERIOD TO THE SATISFACTION OF THE TOWN AND THE APPLICABLE CONSERVATION AUTHORITY.
- f. A MINIMUM OF 1.2m CLEARANCE IS TO BE PROVIDED FROM THE LIMITS OF ALL SIDEWALKS AND DRIVEWAYS TO EXISTING UTILITY STRUCTURES WITHIN THE MUNICIPAL RIGHT OF WAY. IF THIS CLEARANCE IS NOT MAINTAINED THEY SHALL BE RELOCATED AT THE APPLICANT'S EXPENSE.
- g. STREET CURBS ARE TO BE CONTINUOUS THROUGH THE PROPOSED ENTRANCE.
- h. MUNICIPAL SIDEWALKS SHALL BE CONTINUOUS THROUGH ALL ENTRANCES TO THE SITE AND THE CURB SHALL BE TAPERED BACK 600MM. SIDEWALKS SHALL BE COMPLETELY REMOVED AND REPLACED WITH A 180mm MINIMUM CONCRETE THICKNESS, 30MPa AND 5% TO 7% AIR ENTRAINMENT AT ALL PROPOSED INDUSTRIAL, COMMERCIAL AND INSTITUTIONAL ENTRANCES.
- i. ANY CHANGES TO GRADES OR SERVICING FROM THE ORIGINAL APPROVED SITE PLAN MUST BE SUBMITTED BY THE ENGINEER TO THE TOWN FOR APPROVAL PRIOR TO CONSTRUCTION.
- j. STRUCTURAL DESIGN OF THE FIRE ROUTE IS REQUIRED TO SUPPORT AN 18 TON VEHICLE.
- k. ALL BOULEVARDS TO BE RESTORED WITH 150mm MINIMUM OF TOPSOIL AND SOD TO THE SATISFACTION OF THE TOWN OF CALEDON PUBLIC WORKS AND ENGINEERING DEPARTMENT.
- l. THE MINIMUM PAVEMENT DESIGN FOR THE ASPHALT DRIVEWAY APRON WITHIN THE MUNICIPAL ROAD ALLOWANCE SHALL BE AS FOLLOWS:  
40mm HL3 ASPHALT  
50mm HL8 ASPHALT  
150mm GRANULAR 'A'  
300mm GRANULAR 'B'
- m. THE CONSULTANT SHOULD REVIEW THE ABOVE WITH RESPECT TO THE EXPECTED USAGE.  
n. SERVICE CONNECTION BACKFILL TO BE DISCUSSED WITH THE TOWN.

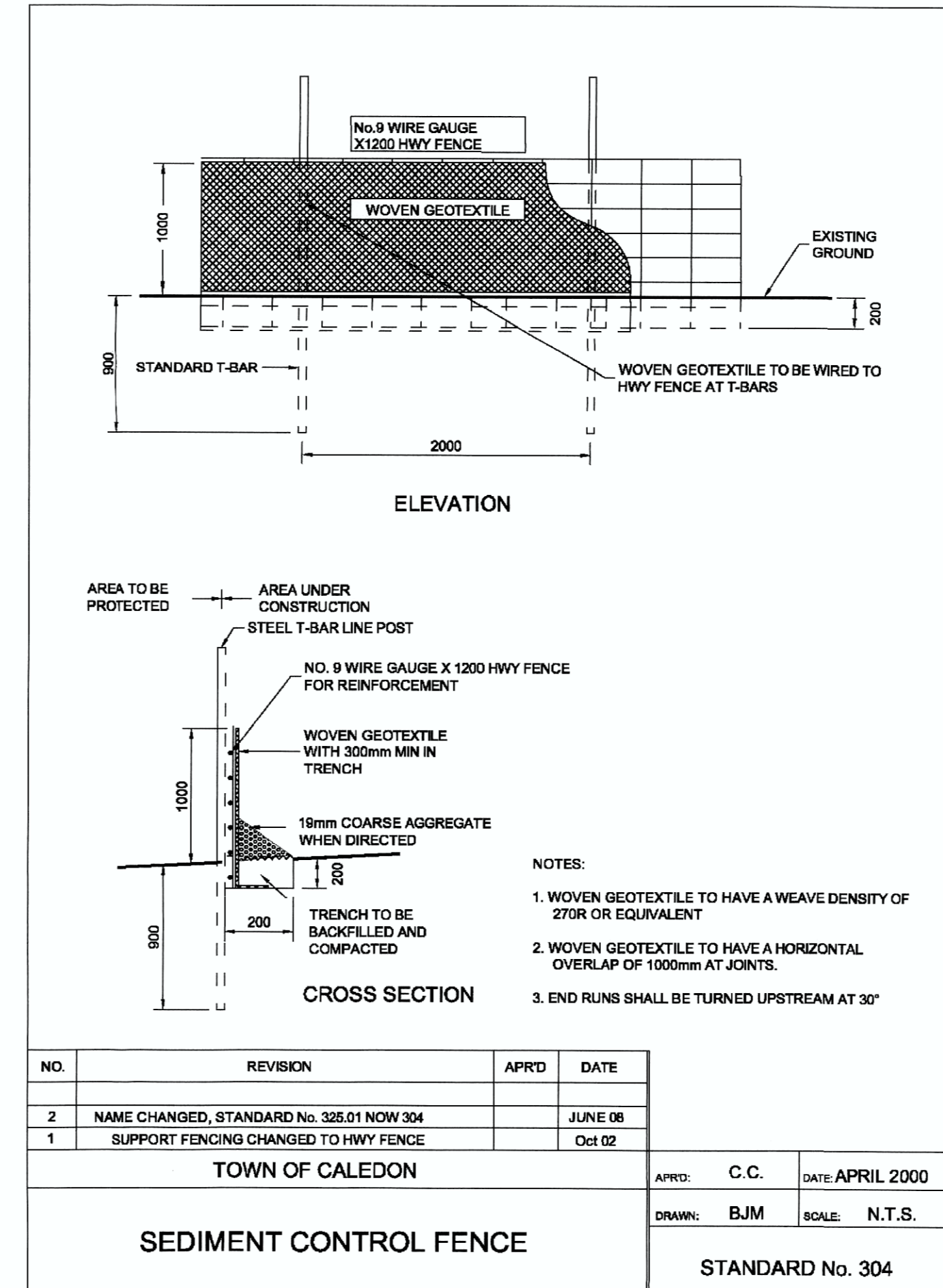
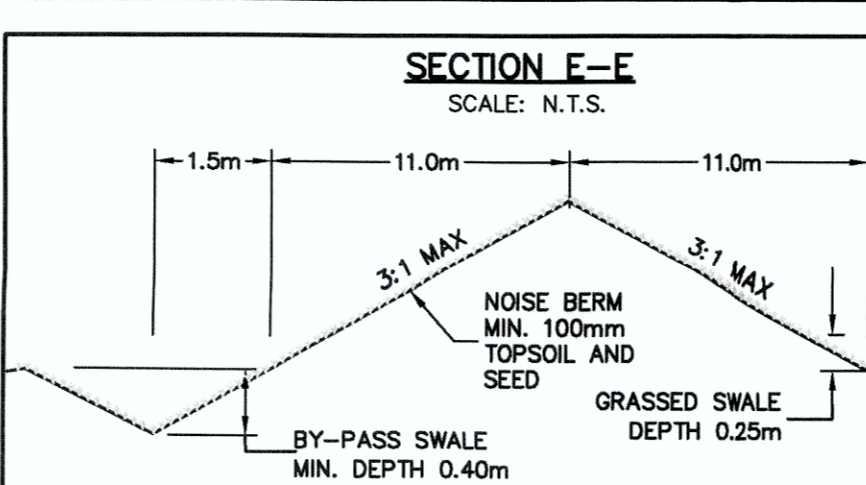
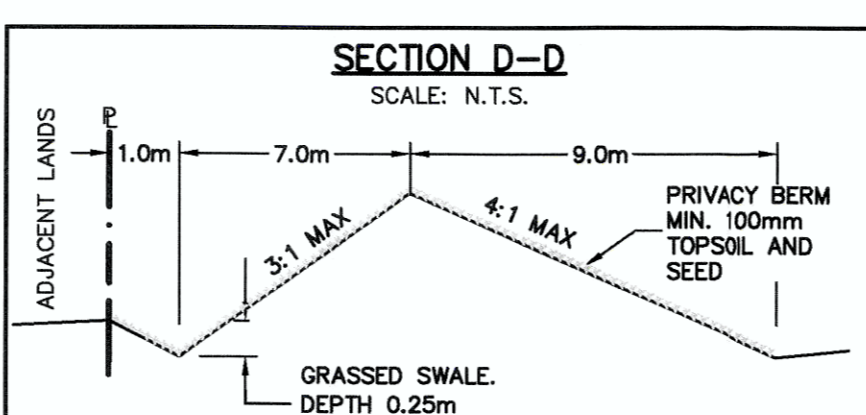
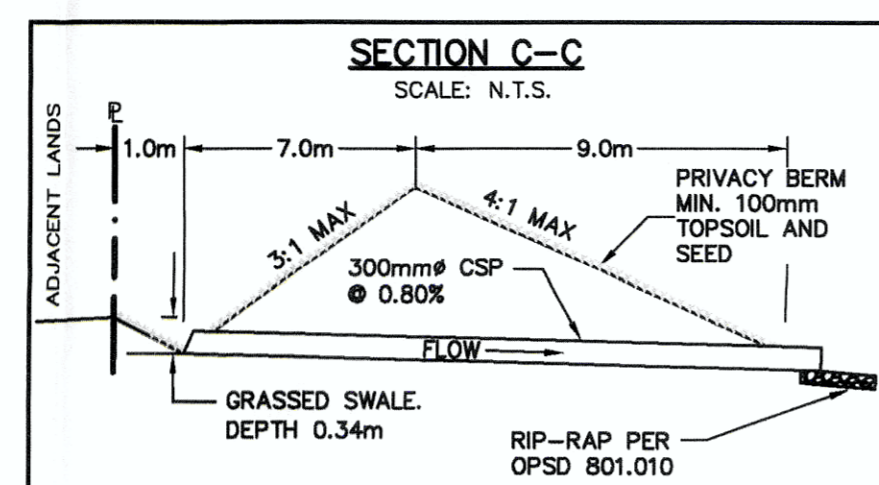
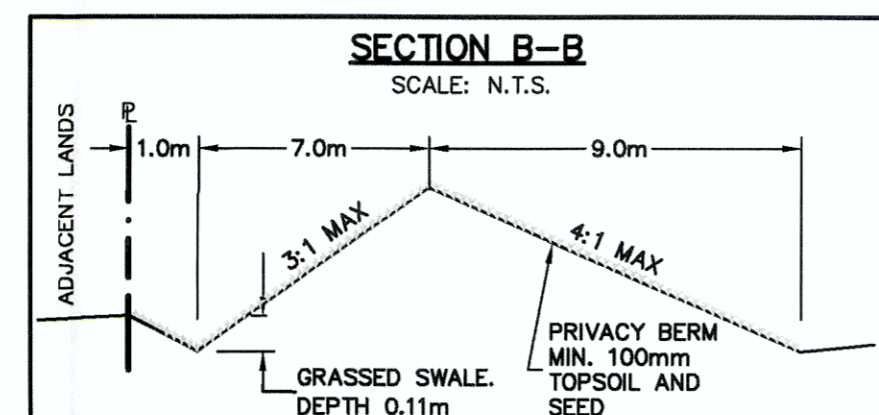
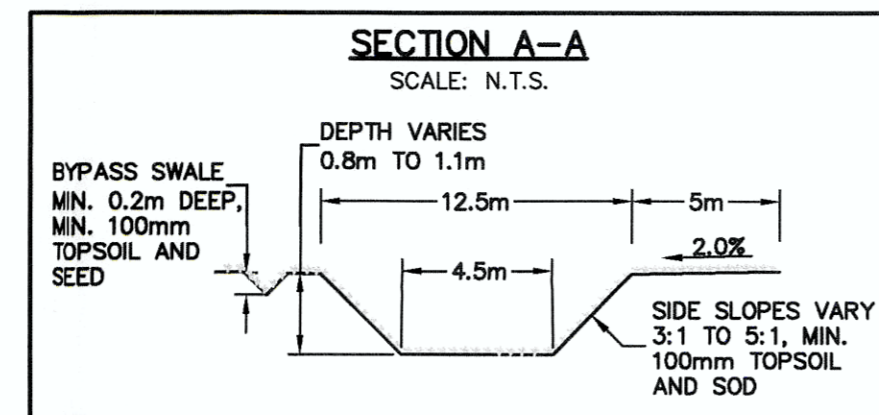

**TOWN OF CALEDON  
PLANNING  
RECEIVED  
September 11, 2024**

RECEIVED  
AUG 30 2017  
PLANNING DEPARTMENT

**TOWN OF CALEDON**  
Site Plan Approved  
As of: Feb. 6/18  
FILE No. SPA 15-30  
Mehmet Mohr  
Lead Planner

SPA #15-30

Engineer  
N. MOGAN  
100061476  
PROVINCE OF ONTARIO

No.	ISSUE / REVISION	DATE
3	RE-ISSUED FOR SPA	2017/03/01
2	RE-ISSUED FOR SPA	2016/10/28
1	RE-ISSUED FOR SPA	2016/03/24
0	ISSUED FOR 1st SUBMISSION SPA	2015/06/22

**ELEVATION NOTE:**

ELEVATIONS SHOWN ON THIS PLAN ARE DERIVED FROM THE TOWN OF CALEDON BENCHMARK No. 40, HAVING A PUBLISHED ELEVATION OF 222.165 METERS.

**SURVEY NOTES:**

SURVEY COMPLETED BY ALLIANCE SURVEYS INC. ON THE 9TH DAY OF MARCH, 2012. REFERENCE No. 12-4004. LEGAL INFORMATION TAKEN FROM SURVEY PLAN BY H. PILLER CORP. INC. DATED OCTOBER 17, 2008. DISTANCES ARE GROUND AND CAN BE CONVERTED TO GRID BY MULTIPLYING BY THE COMBINED SCALE FACTOR OF 0.9999781

**SITE PLAN NOTE:**

SITE PLAN PREPARED BY WESTON CONSULTING, DATED AUGUST, 11 2016

**DRAWING NOTES:**

THIS DRAWING IS THE EXCLUSIVE PROPERTY OF C.F. CROZIER & ASSOCIATES INC. AND THE REPRODUCTION OF ANY PART WITHOUT PRIOR WRITTEN CONSENT OF THIS OFFICE IS STRICTLY PROHIBITED.

THE CONTRACTOR SHALL VERIFY ALL DIMENSIONS, LEVELS, AND DATUMS ON SITE AND REPORT ANY DISCREPANCIES OR OMISSIONS TO THIS OFFICE PRIOR TO CONSTRUCTION. THIS DRAWING IS TO BE READ AND UNDERSTOOD IN CONJUNCTION WITH ALL OTHER PLANS AND DOCUMENTS APPLICABLE TO THIS PROJECT. DO NOT SCALE THIS DRAWING. ALL EXISTING UNDERGROUND UTILITIES TO BE VERIFIED IN THE FIELD BY THE CONTRACTOR PRIOR TO CONSTRUCTION.

Project  
**7904 MAYFIELD ROAD  
TOWN OF CALEDON**

**CONSTRUCTION NOTES  
AND DETAILS**

Drawn: M.M. Design: R.A.A. Project No: **612-3293**

Check: J.R.S. Check: N.C. Scale: N.T.S. Dep: **C 02**

**CROZIER & ASSOCIATES ENGINEERS**

2800 HIGH POINT DRIVE  
SUITE 100  
MILTON, ON L9T 6P4  
905-875-0026 T  
905-875-4915 F  
WWW.CFCROZIER.CA